

# Single Low Intensity Obstruction Light AV-OL-LI

---

Installation & Service Manual - V2.0



*"We Believe Technology  
Improves Navigation."*

# Manual Update Register

---

Version No.	Description	Date	Reviewed	Approved	Design
2.0 (Current)	AV-OL-LI Product Manual Release	November 2021	P. Naidu	W. Evans	M. Sugars

# Contents

---

1.0 Introduction .....	4
2.0 Technology .....	5
3.0 AV-OL-LI Model.....	6
4.0 AV-OL-LI Data Sheet.....	8
5.0 Safety Information.....	9
6.0 Operation and Setup.....	10
6.1 GPS Synchronisation .....	10
7.0 Unpacking, Installation and Wiring .....	11
7.1 Unpacking.....	11
7.2 Installation and Wiring .....	11
7.3 Testing Procedure .....	14
8.0 Maintenance and Servicing.....	15
9.0 Troubleshooting .....	17
10.0 Warranty.....	17
11.0 Notes.....	18

# 1.0 Introduction

---

Congratulations! By choosing to purchase an Avlite light, you have become the owner of one of the most advanced obstruction lights in the world.

Avlite Systems draws on more than 25 years experience in the design and manufacture of navigation aids, and particular care has been taken to ensure your light gives years of trouble free service.

As a commitment to producing the highest quality products for our customers, Avlite has been independently certified as complying with the requirements of ISO 9001:2015 quality management system.

By taking a few moments to browse through this booklet, you will become familiar with the versatility of your light, and be able to maximise its operating function.

Please remember to complete the Avlite warranty registration at [www.avlite.com](http://www.avlite.com).

## 2.0 Technology

---

Avlite Systems is a world-class lighting systems manufacturer with a proven reputation for rapid, innovative, and agile technology solutions designed specifically for defence, government, civil and humanitarian aid operations in the most remote, toughest environments.

### Electronics

Avlite employs leading in-house electronic engineers in the design and development of software and related circuitry. All individual electronic components are sourced directly by Avlite procurement staff ensuring that only the highest quality components are used in our products.

### LED Technology

All Avlite lights use the latest advancements in LED (Light Emitting Diode) technology as a light source. The major advantage of LED's over traditional light sources is well established in that they typically have an operational life in excess of 100,000 hours, resulting in substantial savings to maintenance and servicing costs.

### Precision Construction

Commitment to investing in the design and construction of injection-moulded parts including optic lenses, light bases and a range of other components ensures that all Avlite products are of a consistent and superior quality.

### Optical Performance

Avlite manufactures a range of aviation LED lenses moulded from multi-cavity dies. The company has superior in-house lens manufacturing capabilities to support outstanding optical performance.

### Award-winning, Patented Technology

Several United States and Australian patent registrations are held on Avlite's range of innovative designs, with other regional patents pending in Canada, United Kingdom and Europe.

## 3.0 AV-OL-LI Model

---

This AV-OL-LI light fixture is a steady burning or flashing, low intensity LED obstruction light designed to comply with either FAA (L810 or L-810(F)) or ICAO (LIOL Type A, B or E) requirements. The model can be used for marking obstacles which pose a threat to aircraft, such as telecommunication towers, wind turbines, buildings and other tall structures.

Avlite's LED obstruction lights offer an ultra bright, energy efficient and cost effective lighting solution.

The light fixture is available in DC (24-60VDC). The advanced light optic uses a single LED for minimal power consumption. The corrosion resistant, polycarbonate lens is specifically designed for use with LEDs to maximize light intensity and uniformity.

The light fixture incorporates internal diagnostic checking and an alarm contact for remote monitoring. The alarm relay will be released whenever there is a problem e.g. no power, supply voltage too low, LED failure, etc. The alarm relay will remain energized during the day when operating normally.

### 3.1 Available Options

- Controller with Satcom and GSM Connectivity (See our AV-OL-CTRL Controllers)
- Solar add-on
- Mounting fixtures



### Technical Illustrations

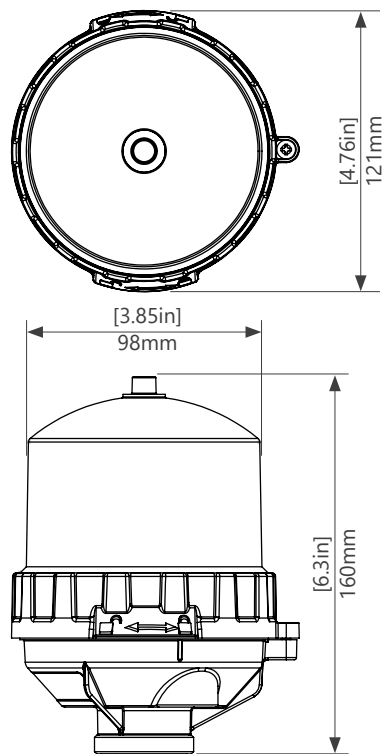

## 4.0 AV-OL-LI Data Sheet

Light Characteristics	
Light Source	LED
Colour	Red/IR
Peak intensity (cd)	Complies with ICAO Low Intensity Type A, B and E
Horizontal Output (degrees)	360
Vertical Divergence (degrees)	As per ICAO specifications
Reflector Type	Single LED Optic
Operation Mode Adjustment	User adjustable between dusk till dawn and 24 hour operation
LED Life Expectancy (hours)	<100,000
Electrical Characteristics	
Operating Voltage	12-48 VDC
Power (W)	TBA
Circuit Protection	Integrated
Temperature Range	-40 to 55°C
Physical Characteristics	
Body Material	LEXAN® Polycarbonate - UV stabilised
Lens Material	LEXAN® Polycarbonate - UV stabilised
Lens Diameter (mm/inches)	98 / 3.85
Mounting	3/4 inch pipe thread
Height (mm/inches)	160 / 6.30
Width (mm/inches)	121 / 4.76
Mass (kg/lbs)	0.5 / 1.1
Service Life	12 years plus
Environmental Standards	
Shock	MIL-STD-202G, Test Condition G, Method 213B
Vibration	MIL-STD202G, Test Condition B, Method 204
Wind Speed	Up to 240 kph / 150 mph
Humidity	0 to 100%
Compliance	
EMC	EN61000-6-4:2019 EN61000-6-2:2019
Quality Assurance	ISO9001:2015
ICAO	Low Intensity Obstruction Light - Type A, B and E
Other	
Warranty	5 year warranty
Options Available	Add on solar system for DC variant. Mounting accessories. Obstruction Controller with SATCOM or GSM available. Turn-key kit based on structure.
Terms and Conditions*	Please refer to the light installation manual for further specifications.  Warranty Terms and Conditions available at <a href="http://www.avlite.com">www.avlite.com</a>



## 5.0 Safety Information

---

Before proceeding with installation or service, make sure the following conditions are met:

- Ensure power lines are not 'live' (NO ELECTRICAL HAZARD)
- Avoid touching live circuits!
- Avoid touching any component or any part of the circuitry while the unit is operating. Do not change components or make adjustments inside the unit with power on.
- Make sure the light fixture mounting is vertically aligned to guarantee the required beam pattern of the airfield light.
- Make sure any nearby obstacles do not impede the lights' beam pattern.
- When installing, comply with all local electrical code(s).
- Mains power should always be disconnected when work is being done in close proximity to electrical fittings, and electrical work should only be done by a licensed electrician.
- Operate the light only within the indicated electrical ratings and product usage instructions.
- To ensure that the light and peripheral equipment function safely and correctly, use cable in compliance with the effective local electrical code.
- Do not stare at the LED or shine the LED into your eyes or those of another person.
- Dispose of the product according to the local laws and regulations for your region, for example, at a recycling centre that accepts electronic devices.
- Ensure the tower or mast is grounded (NO RF HAZARD).
- Check the mast lighting circuit is not faulty.
- Make sure the mounting pole is vertically aligned to guarantee the required beam pattern of the obstruction light.

## 6.0 Operation and Setup

---

When powered up, the light will constantly check day/night status using its internal ambient light sensor. The ambient light sensor averages its measurement for 30 seconds.

**FAA:** By default the lights turn ON when the ambient light decreases to not less than 35 footcandles (376.7 lux) and turn OFF when the ambient light increases to not more than 60 footcandles (645.8 lux).

**ICAO:** By default the lights turn ON when the ambient light decreases to not less than 100 lux and turn OFF when the ambient light increases to not more than 150 lux.

In night mode, the LI will be illuminated as either a red, steady burning (ICAO Type A and B and FAA L-810) or flashing (ICAO Type E and FAA L-810F) fixture. In day mode, the fixture will not be illuminated.

### Light intensity & operation mode setting for FAA compliant light fixture

The FAA compliant model comes pre-set to the correct intensity for L-810 steady or L-810(F) flashing burning red obstruction light in dusk-till-dawn mode. The intensity and operation mode is pre-set in the factory and does not need to be set by the user.

### Light intensity & operation mode setting for ICAO compliant light fixture

The fixture will be supplied with the ICAO compliant optic. The obstruction light will be pre-set to the intensity setting specified by the customer for a red steady burning (ICAO Type A or ICAO Type B) or flashing (ICAO Type E) Low Intensity Obstruction Light in dusk-till-dawn mode. The intensity and operation mode is pre-set in the factory and does not need to be set by the user.

**Note:** The ICAO Model and FAA Model have their own unique optic. The ICAO model cannot be used for FAA purposes and the FAA model cannot be used for ICAO purposes. The model required needs to be specified at the time of order.

## 6.1 GPS Synchronisation

Avlite has utilised the latest advancements in GPS technology to develop an internal synchronisation system that is incorporated into the lights. Using overhead satellites, multiple LI fixtures (ICAO Type E and FAA L-810F only) are able to synchronise with other obstruction lights set to the same flash pattern. No additional power supplies, aerials or control systems are required, and with its microprocessor-based system, the GPS option is specifically designed to provide maximum reliability and performance over a wide range of environmental conditions.

### Operating Principle

Each light operates independently and requires no operator intervention. A minimum of 4 satellites need to be in view for the built-in GPS receiver to collect time data. At dusk, the light sensor will turn the light on. If time data is available, the LI will come on synchronised to every other obstruction light with the same selected flash code. Synchronisation is achieved using an internal algorithm based on the highly accurate time base and time data received from the satellites. The satellite data is provided from a number of earth stations using atomic clocks as the time base. Continuous self-checking ensures that the lights will continue to run in synchronisation.

### Light Activation

At power-up the microprocessor checks that the internal GPS module is programmed correctly and is able to provide valid time base and time data. Once outside with a clear view of the sky, valid data should become available within 20 minutes.

**Note:** Lights will not synchronise if different flash codes are selected.

## 7.0 Unpacking, Installation and Wiring

---



**WARNING:**

DO NOT connect directly to an unregulated power source. Connecting to an unregulated source may result in damage.



**WARNING:**

Do not stare into light emitting diode (LED) beams.



**WARNING:**

LED lights contain glass components. Do Not Drop. Always follow the instructions outlined in the product manual when cleaning the equipment. Improper cleaning methods and use of unauthorized cleaning agents can damage equipment.

### 7.1 Unpacking

Unpack all hardware and inspect for damage. If there is any damage, please contact your Avlite Office.

Retain original packing material for possible future use in shipping.

### 7.2 Installation and Wiring

Open the LI fixture. Please see section 'Opening and Closing the LI' for further information.

Connect the provided input power cable according to DC installations as shown in the wiring diagram on the following page.

**Note:** The fixture must be wired by a qualified electrician.

Thread a 3/4 inch pipe thread cord grip to the LI and attach the light to an owner supplied bracket or optional Avlite Right Angle Mounting Bracket (for low intensity fixtures) with a locking nut.

**Note:** Make sure the mounting pole is vertically aligned to guarantee the required beam pattern of the obstruction light. Make sure the light's beam pattern is not disturbed by any nearby obstacles

## Opening and Closing the LI

Open the Obstruction Light by removing the locking screw. In order to open the unit, the top half of the unit should be turned anti-clockwise with respect to the bottom half. The top half will turn approximately 20mm over a positive "click" before separating from the bottom half. Attention should be paid to the restriction caused by the internal cabling which is secured by a cable gland.

The unit is closed by reversing the above procedure, ensuring the black rubber O-ring remains in place. Replace O-ring if perished.



## DC Power Connection

The unit is designed to operate from a nominal DC voltage from 24V to 60V.

Wire as follows:

- Positive supply (+) = +VDC
- Negative supply (-) = 0V

For location details of the terminals please refer below:

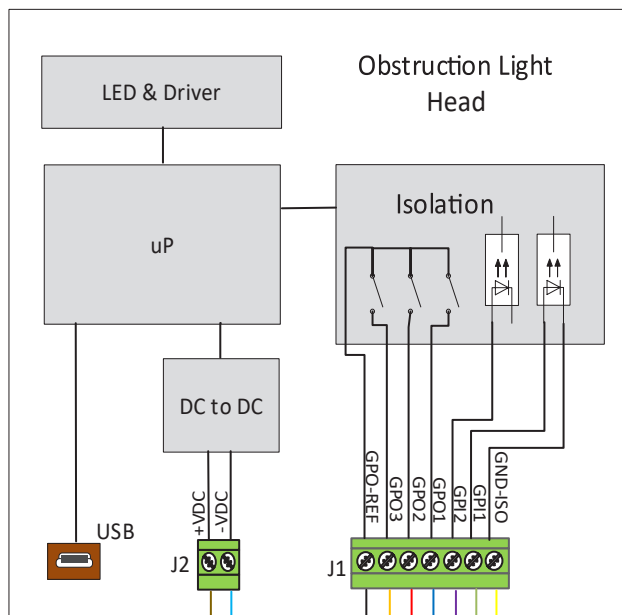

Connector	Signal
J1 GPO-REF	GPO Common
J1 GPO3	General Purpose Contacts 60V/1A Max
J1 GPO2	General Purpose Contacts 60V/1A Max
J1 GPO1	General Purpose Contacts 60V/1A Max
J1 GPI2	General Purpose Input 60V
J1 GPI1	General Purpose Input 60V
J1 GND-ISO	Ground Common Input
J2 +VDC	Positive Supply 24-60V
J2 -VDC	Negative Supply 0V
USB	Light Configuration

## General Purpose Inputs and Outputs

The AV-OL-LI fixture supports a minimum of five discrete IOs via General Purpose Inputs (2) and Outputs (3) in order to meet monitoring requirements as well as provide compatibility with our obstruction lighting controllers.

The I/O configurations must be specified at the time of order.

- General Purpose Inputs (GPI1 and GPI2)

Available Input Type	Description
Disabled	The input line will not be monitored.
Photocell Control	The input line is used to control the state of the photocell/light sensor. Input Low = Night Input High = Day
OpMode Control	The input line is used to control the operation mode used by the lantern. Input Low = Always On Input High = Day and Night

- General Purpose Outputs (GPO1,GPO2 and GPO3)

Available Output Type	Description
Disabled	The output line will remain inactive
Photocell Status	The output line will show the status of the photocell/light sensor. Open Contact = Night Closed Contact = Day
LED Fault	The output line will show the fault state of the LED monitoring. Open Contact = Fault Closed Contact = OK
Visible LED Fault	
IR/NVR LED Fault	
GPS Sync	The output line will show the state of the GPS synchronisation. Open Contact = Not Synchronised Closed Contact = Synchronised

## 7.3 Testing Procedure

**Note:** Avlite recommends that all testing be done during the day.

Check function of the LI by carrying out the following:

- a. Night mode test: Cover the LI fixture and check night operation is functioning as expected. The LI should either flash red (for ICAO Type E or FAA L-810(F)) or operate as a red, steady burning light (for ICAO Type A and B or FAA L-810).
- b. Day mode test: Uncover the LI fixture and check day operation is functioning as expected. The LI should no longer be illuminated.

## 8.0 Maintenance and Servicing

Designed to be maintenance free the Obstruction Lights requires minimal attention, though the following maintenance and servicing information is provided to help ensure the life of your Avlite product.

- Occasional cleaning of the dome lens may be required using a cloth and warm soapy water.

### External 24V Battery System (SLA)

Red Status LED	Name	Voltage	Description
Slow	High	27.0V and above	Voltage is higher than expected, this may indicate a problem with the solar regulator.
Off	Optimal	Between 25.0V – 27.0V	Voltage is correct for a charged battery
1 Quick	Good	Approximately 24.0V	Voltage is correct, this is where the lantern returns to normal operation
2 Quick	Ok	Between 23.5V - 24.0V	Voltage is a little low, but within expectations.
3 Quick	Low	Between 21.0V – 23.5V	Voltage is low, this is where the battery alarm is first activated
4 Quick	Flat	21.0V and below	Voltage is flat, this is where the main LEDs are turned off and the flat battery cutoff is enabled

### External 36V Battery System (SLA)

Red Status LED	Name	Voltage	Description
Slow	High	40.5V and above	Voltage is higher than expected, this may indicate a problem with the solar regulator.
Off	Optimal	Between 37.5V – 40.5V	Voltage is correct for a charged battery
1 Quick	Good	Between 36.0V - 37.5V	Voltage is correct, this is where the lantern returns to normal operation
2 Quick	Ok	Between 35.0V – 36.0V	Voltage is a little low, but within expectations.
3 Quick	Low	Between 32.0V - 35.0V	Voltage is low, this is where the battery alarm is first activated
4 Quick	Flat	32.0V and below	Voltage is flat, this is where the main LEDs are turned off and the flat battery cutoff is enabled

### External 48V Battery System (SLA)

Red Status LED	Name	Voltage	Description
Slow	High	54.0V and above	Voltage is higher than expected, this may indicate a problem with the solar regulator.
Off	Optimal	Between 50.0V – 54.0V	Voltage is correct for a charged battery
1 Quick	Good	Between 48.0V - 50.0V	Voltage is correct, this is where the lantern returns to normal operation
2 Quick	Ok	Between 47.0V – 48.0V	Voltage is a little low, but within expectations.
3 Quick	Low	Between 43.0V - 47.0V	Voltage is low, this is where the battery alarm is first activated
4 Quick	Flat	43.0V and below	Voltage is flat, this is where the main LEDs are turned off and the flat battery cutoff is enabled

## 24V DC Supply System

Red Status LED	Name	Voltage	Description
Slow	High	30.0V and above	Voltage is higher than expected, this may indicate a problem with the solar regulator.
Off	Optimal	Between 24.0V – 30.0V	Voltage is correct for a charged battery
1 Quick	Good	Approximately 24.0V	Voltage is correct, this is where the lantern returns to normal operation
2 Quick	Ok	Between 21.6V - 24.0V	Voltage is a little low, but within expectations.
3 Quick	Low	Between 19.2V – 21.6V	Voltage is low, this is where the alarm output is first activated
4 Quick	Flat	19.2V and below	Voltage is flat, this is where the main LEDs are turned off and the flat battery cutoff is enabled

## 36V DC Supply System

Red Status LED	Name	Voltage	Description
Slow	High	45.0V and above	Voltage is higher than expected, this may indicate a problem with the solar regulator.
Off	Optimal	Between 36.0V – 45.0V	Voltage is correct for a charged battery
1 Quick	Good	Approximately 36.0V	Voltage is correct, this is where the lantern returns to normal operation
2 Quick	Ok	Between 32.4V – 36.0V	Voltage is a little low, but within expectations.
3 Quick	Low	Between 28.8V - 32.4V	Voltage is low, this is where the alarm output is first activated
4 Quick	Flat	28.8V and below	Voltage is flat, this is where the main LEDs are turned off and the flat battery cutoff is enabled

## 48V DC Supply System

Red Status LED	Name	Voltage	Description
Slow	High	60.0V and above	Voltage is higher than expected, this may indicate a problem with the solar regulator.
Off	Optimal	Between 48.0V – 60.0V	Voltage is correct for a charged battery
1 Quick	Good	Approximately 48.0V	Voltage is correct, this is where the lantern returns to normal operation
2 Quick	Ok	Between 43.2V – 48.0V	Voltage is a little low, but within expectations.
3 Quick	Low	Between 38.4V - 43.2V	Voltage is low, this is where the alarm output is first activated
4 Quick	Flat	48.4V and below	Voltage is flat, this is where the main LEDs are turned off and the flat battery cutoff is enabled



## 9.0 Troubleshooting

---

Problem	Possible Cause	Solution
Light will not activate	No power to light	<ul style="list-style-type: none"><li>• Check battery terminals are properly connected.</li><li>• Check battery voltage is above the flat battery threshold.</li></ul>
	Ambient lighting conditions	<ul style="list-style-type: none"><li>• Ensure internal toggle switch is set to the 'ON' position.</li><li>• Ensure light is in darkness.</li><li>• Wait at least 60 seconds for the program to initialise in darkness.</li></ul>
Light will not operate for the entire night.	Insufficient Charging	<ul style="list-style-type: none"><li>• Expose light to direct sunlight and monitor operation for several days. Avlite products typically require 2.5-3.0 minimum hours of direct sunlight per day to retain full autonomy. From a discharged state, the light may require several days of operational conditions to 'cycle' up to full autonomy.</li><li>• Ensure solar module is clean and not covered by shading during the day.</li></ul>
Lights are constantly on during the day.	Incorrect Operation Mode	<ul style="list-style-type: none"><li>• Check the Operational Mode setting in AvlitePro is not set to 'Always ON'</li></ul>

## 10.0 Warranty

---

Refer to Avlite website at [www.Avlite.com](http://www.Avlite.com).

## 11.0 Notes

---



# Contact Us!

---

Avlite's solutions are easy-to-install and scalable. We have a solution for every budget.



## Avlite Head Office

11 Industrial Drive, Somerville  
Victoria, Australia 3912  
T: +61 (0)3 5977 6128  
F: +61 (0)3 5977 6124

## Avlite Asia

8 Wilkie Road, #03-01  
Wilkie Edge, Singapore 228095  
T: +65 9119 8770

## Avlite USA

61 Business Park Drive, Tilton  
New Hampshire, USA 03276  
T: +1 (603) 737 1311  
F: +1 (603) 737 1320

@ info@avlite.com

www.avlite.com

www.star2m.com



*"We Believe Technology  
Improves Navigation."*