

**Avlite**<sup>®</sup>  
www.avlite.com



**AV-OL-KT-I3**  
**Obstruction Lighting Kit**  
ICAO - I3

**INSTALLATION & SERVICE MANUAL**

V1.1



---

<b>Version No.</b>	<b>Description</b>	<b>Date</b>	<b>Reviewed</b>	<b>Approved</b>	<b>Design</b>
1.0	AV-OL-KT-13 Manual Launch	November 2019	P. Naidu	W. Evans	M. Sugars
1.1	Data update	January 2020	P. Naidu	W. Evans	M. Sugars
1.2	Data update	July 2020	P. Naidu	W. Evans	M. Sugars

# Table of Contents

<b>1.0</b>	<b>Introduction</b> .....	<b>4</b>
<b>2.0</b>	<b>Technology</b> .....	<b>5</b>
<b>3.0</b>	<b>AV-OL-KT-E1 Models</b> .....	<b>6</b>
3.1	Available Options .....	9
<b>4.0</b>	<b>AV-OL-KT-E1 Data Sheet</b> .....	<b>10</b>
<b>5.0</b>	<b>Safety Information</b> .....	<b>11</b>
<b>6.0</b>	<b>Operation and Setup</b> .....	<b>12</b>
6.1	System Overview .....	12
6.1.1	AV-OL-CMI .....	12
6.1.2	AV-OL-LI .....	14
6.1.3	T3 Controller .....	16
6.1.4	Interface Wiring .....	17
6.1.5	GPS Synchronisation .....	18
<b>7.0</b>	<b>Unpacking, Installation, Wiring and Setup</b> .....	<b>19</b>
7.1	Unpacking .....	19
7.2	Installation .....	20
7.2.1	Tools Required .....	20
7.2.2	Additional Tools Required .....	21
7.2.3	Cabling Requirements .....	21
7.2.4	Factory Settings .....	21
7.2.5	Installation Recommendation .....	21
7.3	Testing Procedure .....	38
<b>8.0</b>	<b>Maintenance and Servicing</b> .....	<b>39</b>
<b>9.0</b>	<b>Replacement Parts</b> .....	<b>39</b>
<b>10.0</b>	<b>Troubleshooting</b> .....	<b>40</b>



---

# 1.0 Introduction

Congratulations! By choosing to purchase an Avlite product, you have become the owner of one of the most advanced obstruction products in the world.

Avlite Systems draws on more than 25 years of experience in the design and manufacture of navigation aids, and particular care has been taken to ensure your product gives years of trouble-free service.

As a commitment to producing the highest quality products for our customers, Avlite has been independently certified as complying with the requirements of ISO 9001:2015 quality management system.

By taking a few moments to browse through this booklet, you will become familiar with the versatility of your lighting kit, and be able to maximise its operating function.

Please remember to complete the Avlite warranty registration card accompanying your product.

## Acronyms and Abbreviations

The following abbreviations will be used throughout this Installation Manual:

cd	candela
ft.	foot
in.	inch
LED	Light Emitting Diode
VAC	Volts, Alternating Current
VDC	Volts, Direct Current
AWG	American Wire Gauge
CMI	Combined Medium Intensity
LI	Low Intensity
IMAB	ICAO Medium Intensity Type A & Type B
IMAC	ICAO Medium Intensity Type A & Type C

## 2.0 Technology

**Avlite Systems is a world-class solar lighting systems manufacturer with a proven reputation for rapid, innovative, and agile technology solutions designed specifically for defence, government, civil and humanitarian aid operations in the most remote, toughest environments.**

### **Electronics**

Avlite employs leading in-house electronic engineers in the design and development of software and related circuitry. All individual electronic components are sourced directly by Avlite procurement staff ensuring that only the highest quality components are used in our products.

### **LED Technology**

All Avlite lights use the latest advancements in LED (Light Emitting Diode) technology as a light source. The major advantage of LED's over traditional light sources is well established in that they typically have an operational life in excess of 100,000 hours, resulting in substantial savings to maintenance and servicing costs.

### **Precision Construction**

Commitment to investing in the design and construction of injection-moulded parts including optic lenses, light bases and a range of other components ensures that all Avlite products are of a consistent and superior quality.

### **Optical Performance**

Avlite manufactures a range of aviation LED lenses moulded from multi-cavity dies. The company has superior in-house lens manufacturing capabilities to support outstanding optical performance.

### **Award-winning, Patented Technology**

Several United States and Australian patent registrations are held on Avlite's range of innovative designs, with other regional patents pending in Canada, United Kingdom and Europe.



---

## 3.0 AV-OL-KT-I3

The AV-OL-KT-I3 Obstruction Lighting Kit is a full turnkey solution for I3 defined structures ranging between 61-106 meters above ground level (AGL). These include telecommunication towers and utility towers, wind turbines, cranes, buildings and other tall structures.

The I-3 Obstruction Solution comes fully assembled, ready to install, and includes the following items:

- 1 x CMI (Type A & B or Type A & C) Combined Medium Intensity Obstruction Light
- 3 x LI (Type A & Type B) Single Fixture Obstruction Lights
- All necessary junction boxes
- Central Control Unit
- External Photocell

The top light (CMI) remains ON 24 hours a day, illuminated white for daytime operation and red for night operation, while the middle lights (LI Single Fixtures) are illuminated at night only.

The I-3 Obstruction Solution is available in two input power configurations, a universal AC (90-264VAC) or 48 VDC (solar compatible) and comes with Star2M monitoring via GSM or SATCOM as options

The best in class system power draw allows tower owners to utilize solar for locations lacking reliable and/or cost-effective access to regular utility power. Avlite's experience, knowledge and tools for solar applications provides years of maintenance free, off-grid operation with an emphasis on ICAO compliance.

With a range of accessories including brackets, cable and junction boxes, utility and telecommunication companies, electrical contractors and state and local governments can now quickly and easily purchase all obstruction lighting components from a single source, simplifying the ordering process and reducing the possibility of incompatible, stand-alone components from different manufacturers.

**Note: This installation and service manual must be used in conjunction with the installation manuals of the individual components.**

- AV-OL-CMI Installation and Service Manual
- AV-OL-LI Installation and Service Manual



**1 x CMI Obstruction Light (IMAB or IMAC)**

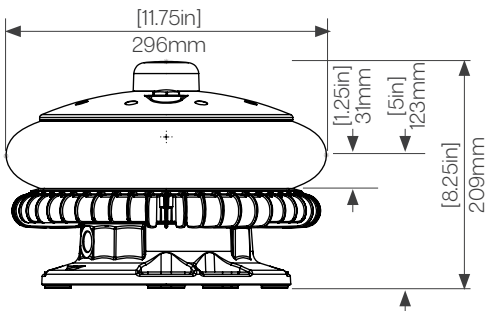

**3 x LI Single Fixture Obstruction Lights AV-OL-LI**

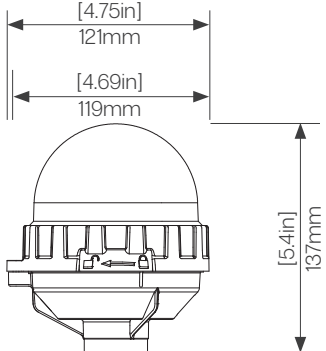

**1 x Control Unit**

Note: Mounting hardware not included.

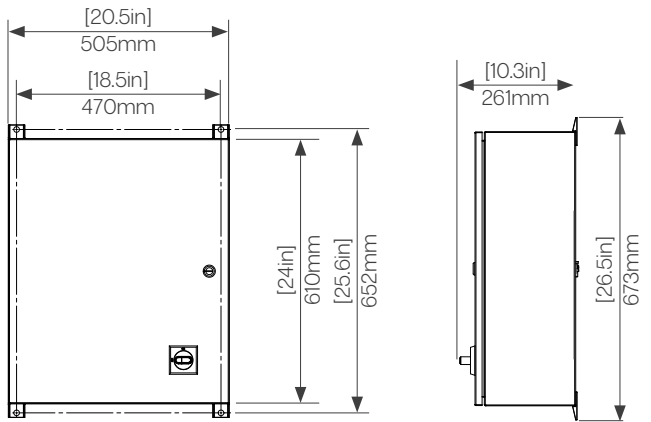



### 1 x Top Level Junction Box

Note: Mounting hardware not included.

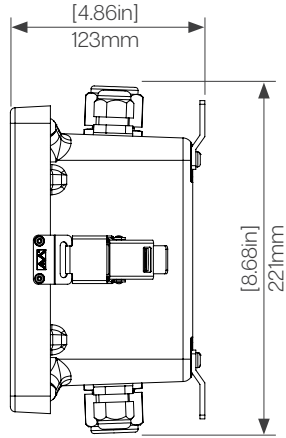
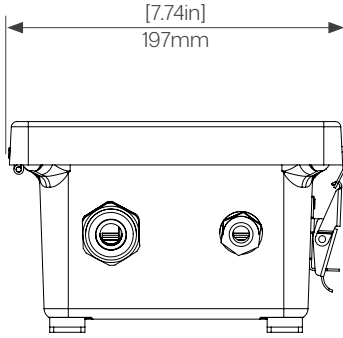

### 1 x Mid Level Junction Box

Note: Mounting hardware not included.

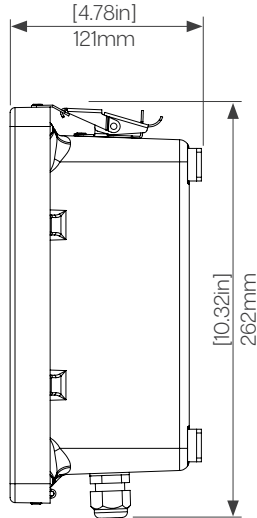
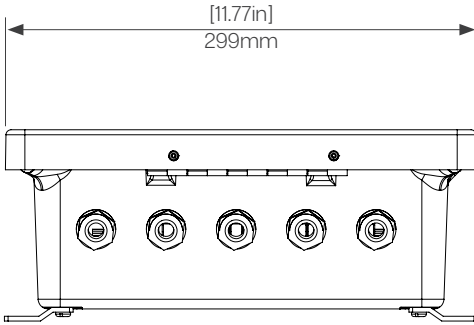



### 3.1 Available Options

- Solar Input Power (for 48VDC) – Call Avlite for details.
- Cable Kit (suitable for 106 m structure) Includes:
  - 114m of 2.5mm<sup>2</sup>, 3 conductor wire
  - 114m of 14mm<sup>2</sup>, 2 conductor wire
  - 99m of 4mm<sup>2</sup>, 5 conductor wire
- Light Mounting Brackets (each)
  - For CMI Type A & B or Type A & C: Right Angle Pole Mounting Bracket-Medium Intensity Fixtures
  - For LI Single Fixture: Right Angle Mounting Bracket-Low Intensity Fixtures
- Remote Monitoring and Control
  - Avlite offers remote Star2M monitoring via GSM or SATCOM.
  - Operators can remotely monitor the status of their installation from a compatible device. The system can also be configured to send out SMS text messages or e-mail alerts to designated operators should alarm conditions be triggered, such as low voltage or light failure.
  - Please contact Avlite for operational information for the Monitoring & Control options. Visit <https://www.star2m.com> to find out more about Star2M
- Mounting Bolt Kit (includes bolts, nuts, washers)
  - Please contact Avlite for further details
- Control Unit Mounting Hardware
  - 2" pipe clamps
  - $\frac{3}{4}$ " pipe clamps

Please contact Avlite for further details.



# 4.0 AV-OL-KT-I3 Data Sheet

ICAO I-3 Obstruction Kit	AC	DC		
<b>Electrical Characteristics</b>				
Input Voltage	90-264VAC	48VDC		
Input Frequency	50/60 Hz	N/A		
<b>Power Consumption</b>				
Peak	555VA	490W		
Average*	Day: 45.5VA Night: 12.5VA	Day: 40W Night: 11W		
<b>Physical Characteristics</b>				
Dimensions	Height (inches/mm)	Width (inches/mm)	Length (inches/mm)	Mass (lbs./kg)
CMI (IMAB or IMAC)	8.25 / 209	11.75 / 296	6.75 / 171	21.5 / 9.7
LI Single Fixture	5.4 / 137	4.75 / 121	3.875 / 100	0.375 / 0.4
Control Unit	24 / 610	20.5 / 505	9.5 / 241	63 / 28.5
Top Junction Box	4.86 / 123	8.68 / 221	7.74 / 197	7.05 / 3.2
Middle Junction Box	4.78 / 121	10.32 / 262	11.77 / 299	9.92 / 4.5
<b>Mounting</b>				
AV-OL-CMI (IMAB or IMAC)	200mm bolt pattern			
LI Single Fixture	½ inch pipe thread			
Control Unit	Wall mounted (mounting accessories available)			
Top Junction Box	Mounting accessories available			
Middle Junction Box	Mounting accessories available			
<b>Certifications and Compliance</b>				
CE	EN61000-6-3:2007, EN61000-6-1:2007			
Quality Assurance	ISO9001:2015			
Protection Rating	Junction and Control Box: IP65/NEMA4X		Lights: IP67	
ICAO	Medium Intensity Type A, Type B and Type C Obstruction Light, ICAO Annex 14, Volume 1, Sixth Edition, July 2013, 'Aerodrome Design and Operations'			
<b>Intellectual Property</b>				
Trademarks	AVLITE® is a registered trademark of Avlite Systems			
Warranty*	5 year warranty on light fixtures 3 year warranty on Control Unit and Junction Boxes			
Options Available	<ul style="list-style-type: none"> <li>• Cable Kit suitable for 106 metre structures</li> <li>• Mounting Brackets for CMI and LI fixtures</li> </ul>			

\* Calculated using Combined Medium Intensity IMAB and LI Type B lights.

+ Please refer to the individual light installation manuals for further specifications

## 5.0 Safety Information

Before proceeding with installation or service, make sure the following conditions are met:

- Ensure the tower or mast is grounded (NO RF OR SHOCK HAZARD)
- Check the mast lighting circuit is not faulty
- Ensure power lines are not 'live' (NO ELECTRICAL HAZARD)
- Avoid touching live circuits!
- Avoid touching any component or any part of the circuitry while the unit is operating. Do not change components or make adjustments inside the unit with power on.
- Make sure the light fixture mounting is vertically aligned to guarantee the required beam pattern of the obstruction light.
- Make sure any nearby obstacles do not impede the lights' beam pattern.
- When installing, comply with all local electrical code(s).
- Mains power should always be disconnected when work is being done in close proximity to electrical fittings, and electrical work should only be done by a licensed electrician.
- Operate the light only within the indicated electrical ratings and product usage instructions.
- To ensure that the light and peripheral equipment function safely and correctly, use cable in compliance with the effective local electrical code.
- Do not stare at the LED or shine the LED into your eyes or those of another person.
- Dispose of the product according to the local laws and regulations for your region, for example, at a recycling centre that accepts electronic devices.



# 6.0 Operation and Setup

## 6.1 System Overview

Avlite's I3 Obstruction Lighting Solution Kit consists of five components: A Control Unit which provides power, day & night control and (optional) remote monitoring, a single red/white omnidirectional, Combined Medium Intensity obstruction beacon (CMI), and three LI Single Fixture red obstruction lights.

The top light fixture (CMI) is designed to comply with either ICAO MIOL Type A & B or Type A & C requirements and the middle lights (LI) comply with ICAO LIOL Type A & B requirements.

Both the CMI and LI Single Fixtures incorporate internal diagnostic checking and an alarm contact for remote monitoring. The alarm relay is energized in normal operation and is released if there is an LED or power fault.

An External Photocell allows the lights to automatically switch between day and night mode. In night mode, the CMI is illuminated red and either flashes (For Type A & B) or remains steady-burning (for Type A & C). The LI single fixtures operate as steady-burning red lights. In day mode, the CMI flashes white while the LI Single Fixtures remain off. The Photocell output can also be overridden for system testing and maintenance via the Photocell Bypass Switch. (See section 6.1.3 for more information).

The Control Unit automatically evaluates the I-3 system for operation and performance criteria while providing local and remote display of information and alarms; operators can conveniently view the lights' real time status from the web based Star2M™ portal (if option purchased).

### 6.1.1 AV-OL-CMI

External

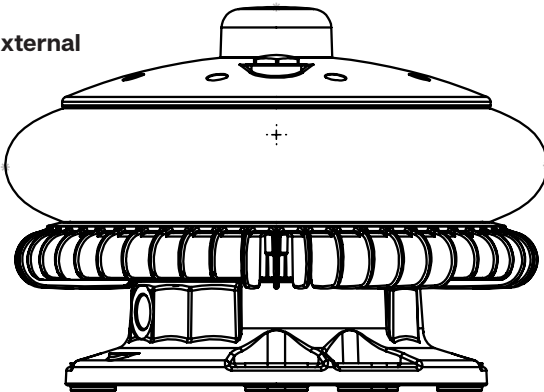

Power	
Positive (+VDC)	Black
Negative (-VDC)	White

Data	
Ground Ref (GNDA)	White
PC Input (IN1)	Black
Alarm Common (COM)	Red
Alarm Signal (NC)	Green

## Lantern Status

The CMI is fitted with one red and one yellow status LED and provides the operator with an indication of the lantern status.

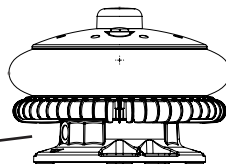

The LEDs are located on the side of the lantern.

The red status LED is used to indicate the health of the lanterns' power system. The yellow status LED is used to indicate the operational status of the lantern. These indicator LED's can be viewed at the base of the lens.

Since the unit can be configured and preset at the factory to operate either at 36VDC or 48VDC the red LED status will behave as follows:

### 36VDC system (DEFAULT)

<b>RED</b>			
<b>Status LED</b>	<b>Lantern Status</b>	<b>Lantern</b>	<b>Condition</b>
Steady	Flat Battery cut off is in effect	OFF	Battery voltage is less than 32.0V
Slow	High Voltage	ON	Battery voltage is above 40.5V
Off	Optimal Voltage	ON	Battery Voltage is between 35.5V – 37.5V
1 Quick	OK Voltage	ON	Battery Voltage is between 36.0V – 37.5V
2 Quick	Low Voltage	ON	Battery Voltage is between 35.0V – 36.0V
3 Quick	Poor Voltage	ON	Battery Voltage is between 32.0V – 35.0V
4 Quick	Flat Voltage	ON	Battery voltage is less than 32.0V

Once the Flat Battery cut-off condition is in effect, the lantern will not turn back on until it sees day light and the battery voltage is above the "OK" threshold for at least one minute.



## 48VDC System

<b>RED</b>			
<b>Status LED</b>	<b>Lantern Status</b>	<b>Lantern</b>	<b>Condition</b>
Steady	Flat Battery cut off is in effect	OFF	Battery voltage is less than 43.0V
Slow	High Voltage	ON	Battery voltage is above 54.0V
Off	Optimal Voltage	ON	Battery Voltage is between 50.0V – 54.0V
1 Quick	OK Voltage	ON	Battery Voltage is between 48.0V – 50.0V
2 Quick	Low Voltage	ON	Battery Voltage is between 47.0V – 48.0V
3 Quick	Poor Voltage	ON	Battery Voltage is between 43.0V – 47.0V
4 Quick	Flat Voltage	ON	Battery voltage is less than 43.0V

<b>YELLOW</b>			
<b>Status LED</b>	<b>Lantern Status</b>	<b>Lantern</b>	<b>Condition</b>
Off	Standby	OFF	Lantern is in Standby Mode
Quick Flashing 0.15s on, 0.15s off	Day To Night Transitioning (Dusk Till Dawn Mode)	OFF	Light is activating and will turn on after detecting 30 seconds of continuous darkness
2 Quick Flashes every 2s	Operational, Not Synchronised	ON	Lantern is in Normal operating condition. It is not connected to any GPS synchronisation
1 Quick Flashes every 2s	Operational, Sync in Progress	ON	Lantern is 're-syncing' with GPS. The lantern re-syncs with the GPS every 15 minutes
Slow Flashing 1.5s on, 1.5s off	Operational, Synchronised	ON	Normal operating condition. Lantern is synchronised to GPS-enabled lanterns
2 Quick flashes every 11s	Operational, Synchronised as Slave	ON	Lantern is a Hard Wire Synchronisation Slave

If the lantern is not fitted with the GPS Synchronisation option, then the following conditions are not possible: 1 Quick Flash, and Slow Flashing.

**For more information regarding the CMI, please consult the relevant sections of the corresponding service and installation manual.**

## 6.1.2 AV-OL-LI

### External

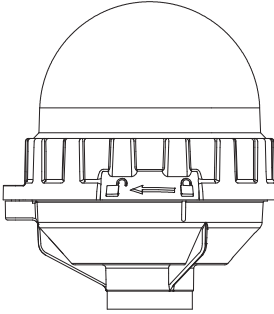

Power and Data	
Positive (+VDC)	Red
Negative (-VDC)	Black
IN1	White
COM	Orange
NO	Green

### Light Intensity & Operation Mode Setting

The fixture will be supplied with the ICAO compliant optic. By default, the ICAO compliant model comes pre-set as an ICAO Type A fixture for a red, steady burning Low Intensity obstruction light in dusk-till- dawn mode.

If the customer should need to change the intensity or operation mode settings of the ICAO compliant model they can do this by changing the INTENSITY DIP switch. Please refer to the table below for DIP switch settings.

Position 1	Position 2	Light Intensity
OFF	OFF	ICAO Low Intensity Obstruction Light Type A (10cd), dusk-till-dawn mode – DEFAULT
OFF	ON	ICAO Low Intensity Obstruction Light Type A (10cd), 24 hour mode
ON	OFF	ICAO Low Intensity Obstruction Light Type B (32cd), dusk-till-dawn mode
ON	ON	ICAO Low Intensity Obstruction Light Type B (32cd), 24 hour mode

For more information regarding the LI Single Obstruction light Fixture, please consult the relevant sections of the corresponding service and installation manual.

### LED Fault

In the event of a singular LED fault, either open circuit or closed circuit across the LED, the light unit will turn off all LED's and actuate the Fault Relay.

**For more information regarding the LI Single Fixture, please consult the relevant sections of the corresponding service and installation manual.**



### 6.1.3 T3 Controller

The T3 Control Unit is an essential component of the I3 Obstruction Lighting Kit as it provides power, control and monitoring of the light fixtures in the system.

For safety and security, the control enclosure comes with a safety interlock which prevents access to the controller while the system is powered on.

The Controller is available in two input power configurations; a universal AC or DC and comes with remote monitoring via Star2M with either GSM or Satcom telemetry types as options.

By default, the control unit comes with 2 dry contacts for external monitoring of both the CMI and LI single light fixtures which receive the associated alarm (i.e. Group 2 for the CMI and Group 1 for the LI single fixture lights) in the event of a power or LED fault.

**Note:** External dry contact monitoring is unavailable if remote monitoring via GSM or Satcom has been enabled

A Photocell Bypass Switch is provided with the Control Unit to override the Photocell output for system testing and maintenance. It is factory-set to AUTO (auto day/night) mode.

To test the function of lights for **day** operation, turn the Photocell Bypass Switch to the **Day** position. The CMI should flash white while the LI Single light fixtures remain off.

To test the function of lights for **night** operation, turn the Photocell Bypass Switch to the **Night** position. The CMI should be illuminated red and should either flash (for CMI Type A & B) or remain steady-burning (for CMI Type A & C). All LI Single Fixtures should be illuminated red in the steady-burning configuration.

To return to the **Auto** mode, return the switch to the **Auto** position.

**Note:** Time delays are to be expected when changing modes. Allow up to 1 minute to change between functions.

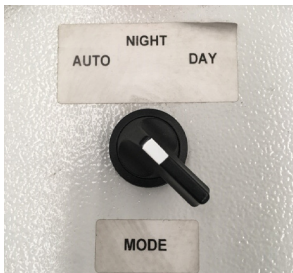



### 6.1.4 Interface Wiring

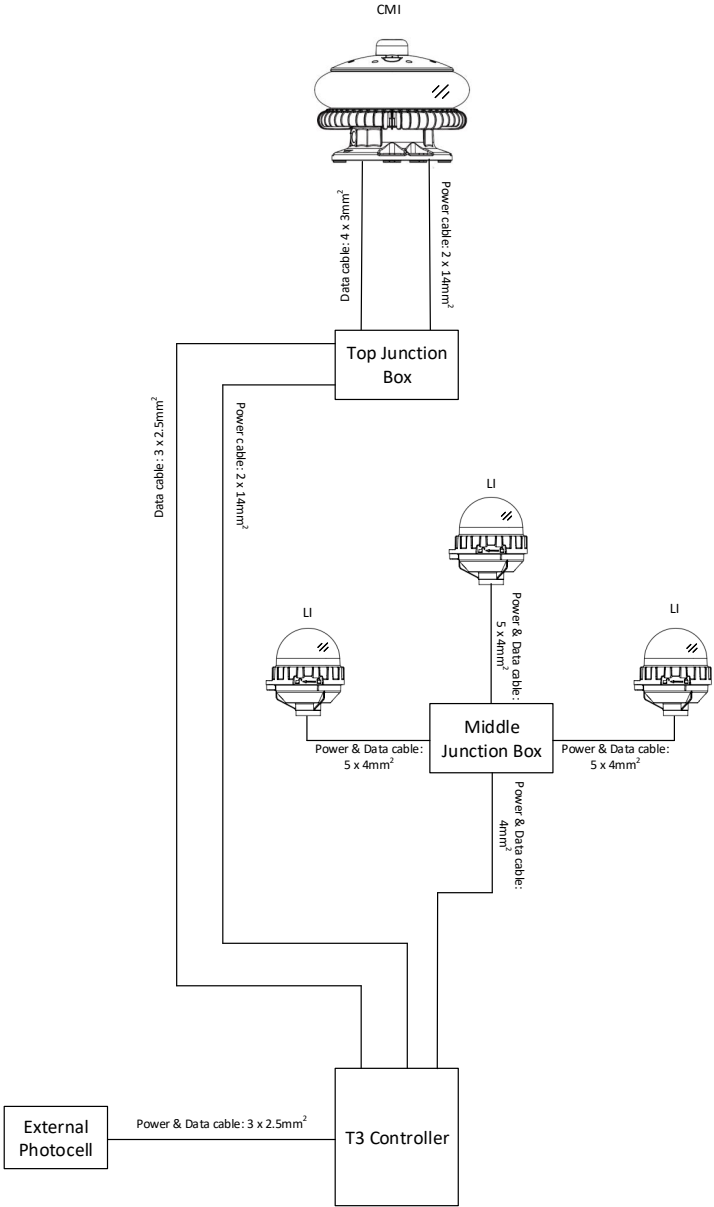



---

## 6.1.5 GPS Synchronisation

Avlite has utilised the latest advancements in GPS technology to develop an internal synchronisation system that is incorporated into the lights. Using overhead satellites, the CMI of multiple I3 Lighting Kits set to the same flash pattern are able to flash in unison. No additional power supplies, aerials or control systems are required, and with its microprocessor- based system, the GPS option is specifically designed to provide maximum reliability and performance over a wide range of environmental conditions.

### Operating Principle

Each light operates independently and requires no operator intervention. A minimum of 4 satellites need to be in view for the built-in GPS receiver to collect time data. At dusk, the light sensor will turn the light on. If time data is available, the CMI will come on synchronised to every other CMI light with the same selected flash code. Synchronisation is achieved using an internal algorithm based on the highly accurate time base and time data received from the satellites. The satellite data is provided from a number of earth stations using atomic clocks as the time base. Continuous self-checking ensures that the light will continue to run in synchronisation.

### Light Activation

At power-up the microprocessor checks that the internal GPS module is programmed correctly and is able to provide valid time base and time data. Once outside with a clear view of the sky, valid data should become available within 20 minutes.

**Note:** Lights will not synchronise if different flash codes are selected.

# 7.0 Unpacking, Installation, Wiring and Setup

## 7.1 Unpacking

Unpack all hardware and inspect for damage. If there is any damage, please contact your Avlite Office.

Retain original packing material for possible future use in shipping.

## 7.2 Installation



**WARNING:**

Confirm that the power switch is toggled to the OFF position when power is connected. **DO NOT** connect power to the PCU when the control panel power switch is toggled to the PWR position. This may result in damage to the power sources.



**WARNING:**

**DO NOT** connect directly to the DC output of a generator, or any other unregulated power source. Connecting to an unregulated source may result in damage.



**WARNING:**

Do not stare into light emitting diode (LED) beams.



**CAUTION:**

LED lights contain glass components. **Do Not Drop.**

**Always** follow the instructions outlined in the product manual when cleaning the equipment. Improper cleaning methods and use of unauthorized cleaning agents can damage equipment.



## 7.2.1 Tools Required

<b>Tools Needed (not supplied)</b>
Flush Cutter
Tongue & Groove Pliers
Silicone Sealant
Cable Jacket Trimmer (optional)
Utility Knife
Electrical Tape
Insulated Terminal Crimper
Wire Strippers 10AWG to 18AWG Range
2.5mm Hex Key
2.0mm Flat Blade Precision Screwdriver
#2 Phillips Screwdriver
Junction Boxes (2) (owner supplied or optional purchase)
Light Mounting Brackets (4) (optional purchase)
Cables (owner supplied or optional purchase)

## 7.2.2 Location

Refer to ICAO Annex 14 Aerodrome Design and Operations Sixth Edition for site requirements for obstruction lights.

### 7.2.3 Cabling Requirements

The installation of the AV-OL-KT-I3 Obstruction Lighting Kit requires the following cables (if optional cable kit is not purchased):

Reference Point	Cable
CMI -Top Junction Box	<ul style="list-style-type: none"> <li>Power Cable: 14mm<sup>2</sup>, 2 Conductor.</li> <li>Data Cable: 3mm<sup>2</sup>, 4 Conductor.</li> </ul>
Top Junction Box - Control Unit	<ul style="list-style-type: none"> <li>Power Cable: 14mm<sup>2</sup>, 2 Conductor.</li> <li>Data Cable: 2.5mm<sup>2</sup>, 3 Conductor.</li> </ul>
LI Single Fixture- Middle Junction Box:	<ul style="list-style-type: none"> <li>Power &amp; Data Cable (x3) = 4mm<sup>2</sup>, 5 Conductor.</li> </ul>
Middle Junction Box- Control Unit	<ul style="list-style-type: none"> <li>Power &amp; Data Cable = 4mm<sup>2</sup>, 5 Conductor.</li> </ul>
Photocell - Control Unit:	<ul style="list-style-type: none"> <li>Power &amp; Data Cable = 2.5mm<sup>2</sup>, 3 Conductor.</li> </ul>

### 7.2.4 Factory Configuration

- CMI wired with 3 metre flying leads (Power cable and Data cable).
- 1 x LI Single Fixture wired with 3 metre flying lead.
- 2 x LI Single Fixtures wired with 7.5 metre flying leads.
- External Photocell wired with 7.5 metre flying lead.

### 7.2.5 Installation Recommendation

**Note:** The sequence of steps can be adjusted for site requirements.

1. Wire and test the system on ground level.

Conduct a basic functional check to ensure that the lights turn on as expected. See section 7.3 *Testing Procedure* for more information.



## 2. Mount the Control Unit

The Control Unit should be mounted in a reasonable location at eye level to ensure that it is easily accessible for servicing and maintenance. There should be plenty of clearance around all sides to allow direct access when the door of the control unit is completely open.

- a. Attach the required mounting hardware to the top and bottom of the Control Unit.

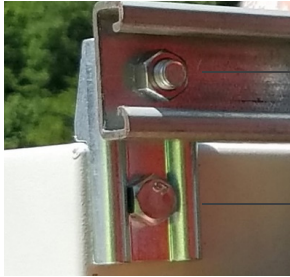

Example of Control Unit mounting hardware

Pre-installed Control Unit tab

- b. Mount the Control Unit (with the previously attached mounting hardware) to the tower or installation structure using the mounting tabs. Secure using the required mounting fixtures.



**Note:** Mounting hardware is not included with the kit.

### 3. Mount External Photocell

Insert the Photocell into the mount (Avlite supplied) by inserting the contact blades into the receptacle. Secure the Photocell assembly to the tower or installation structure using the required mounting fixtures.

The following considerations should be taken into account when mounting the external Photocell:

- Mount in a reasonable location at eye level to ensure that it is easily accessible for servicing and maintenance.
- The Photocell should be pointed away from the equator (North in Northern Hemisphere, South in Southern Hemisphere).
- The Photocell should be located away from bright, artificial lighting.

**Note:** Mounting fixtures are not supplied.





#### 4. Wire the Photocell to the Control unit and cut cable to the required length.

##### Wiring instructions-Power and Data Cable:

- Connect the black positive conductor from the External Photocell to the circuit breaker on the 'PC +24VDC' labelled terminal block in the Control Unit
- Connect the white negative conductor from the External Photocell to the 'PC Com' labelled terminal block in the Control Unit
- Connect the green Photocell signal conductor to the 'PC Signal' labelled terminal block in the Control Unit

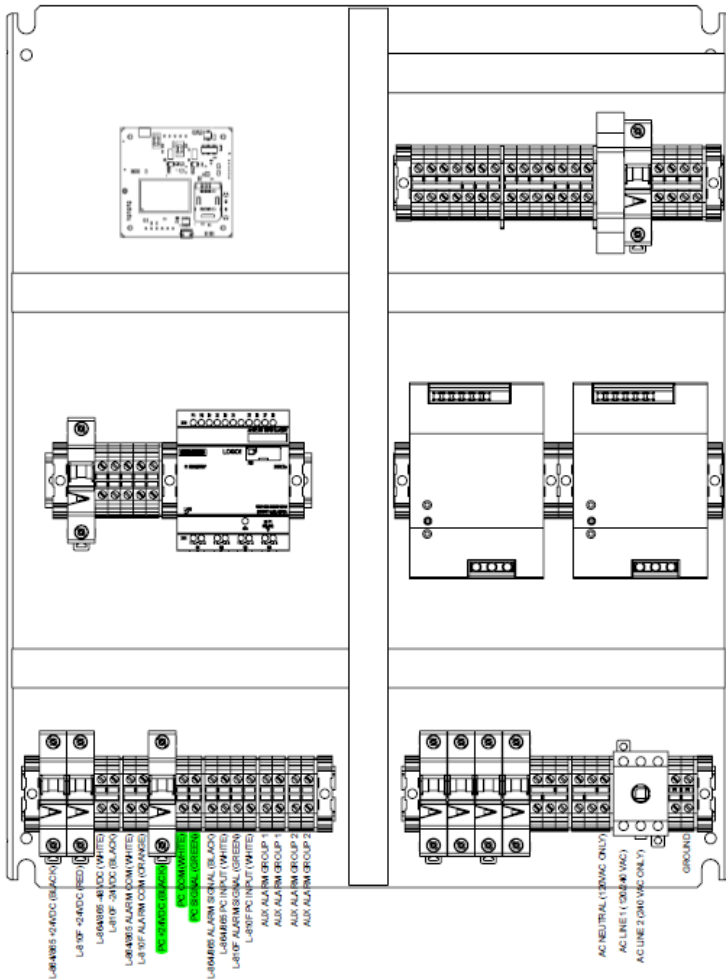

Refer to section 7.2.3 *Cabling Requirements* for recommended cable sizes.



## 5. Install the CMI

Mount the CMI Obstruction light directly to the top of the tower or installation structure either by securing it to the mounting plate or by attaching an optional Avlite Right Angle Pole Mounting Bracket (for medium intensity fixtures) to the tower and bolting the CMI to the bracket.

## 6. Mount the top junction box.

**Note:** Mounting hardware for junction boxes is not supplied.

## 7. Wire CMI to top junction box

- a. Wire CMI power cable to junction box, then wire data cable to junction box.

Wiring instructions-Power Cable:

- Connect the black positive conductor from the CMI to the +48VDC labelled terminal block in the top junction box
- Connect the white negative conductor from the CMI to the -48VDC labelled terminal block in the top junction box

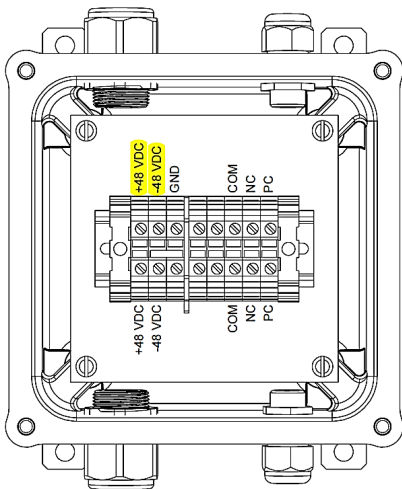



### Wiring Instructions-Data Cable:

- Connect the white Ground Ref (GNDA) conductor from the CMI to the GND labelled terminal block in the top junction box
- Connect the red Alarm Common (COM) conductor from the CMI to the COM labelled terminal block in the top junction box
- Connect the green alarm signal (NC) conductor from the CMI to the NC labelled terminal block in the top junction box
- Connect the black Photocell Input (IN1) conductor from the CMI to the PC labelled terminal block in the top junction box
- 

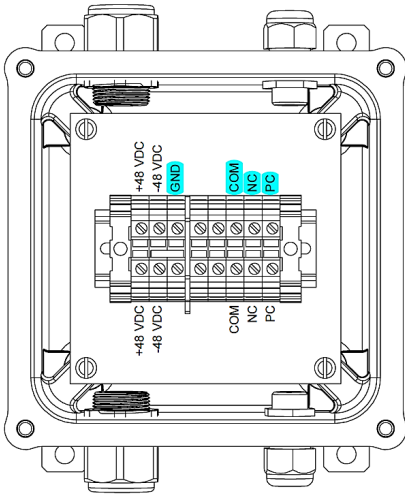

- b. Run two cables from the top junction box to the Control Unit, one for power and one for data.

Refer to section 7.2.3 *Cabling Requirements* for recommended cable sizes.

8. Route top junction box to control unit cables

Wiring instructions-Power Cable:

- Connect the black positive conductor from the +48VDC labelled terminal in the top junction box to the 'CMI +24VDC' labelled terminal block in the Control Unit
- Connect the white negative conductor from the -48VDC labelled terminal in the top junction box to the 'CMI -48VDC' labelled terminal block in the Control Unit

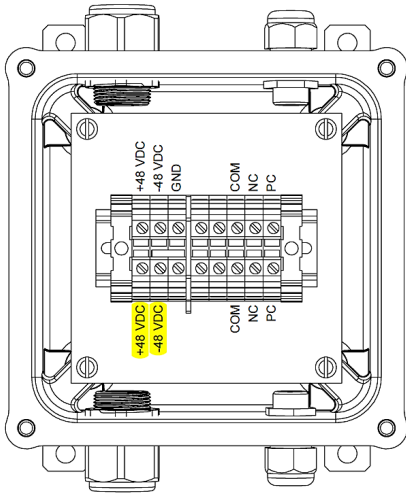

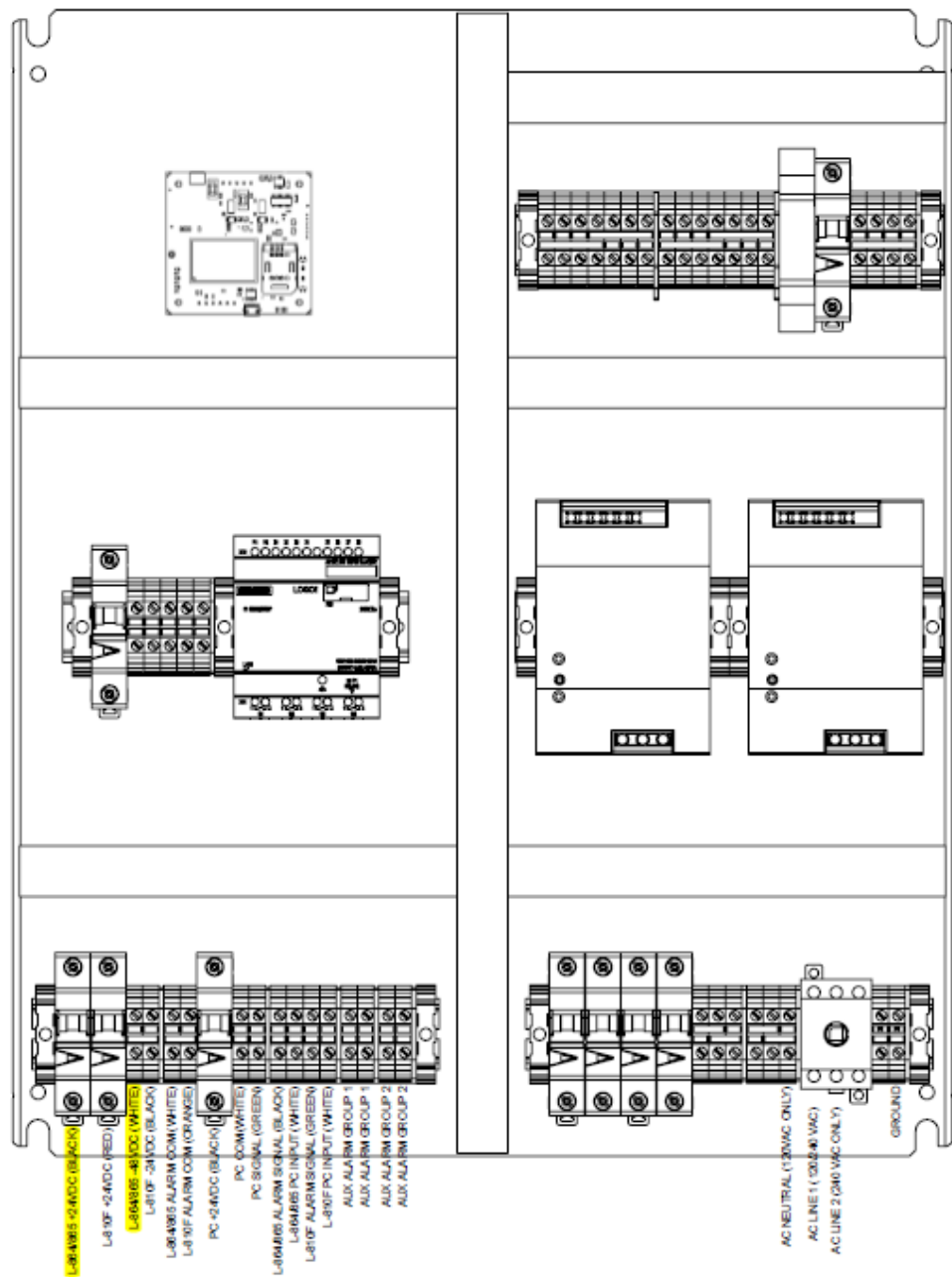

### Wiring instructions-Data Cable:

- Connect the white Alarm Common (COM) conductor from the top-level junction box to the 'CMI Alarm Com' labelled terminal block in the Control Unit
- Connect the black alarm signal (NC) conductor from the top-level junction box to the 'CMI Alarm Signal' Labelled terminal block in the Control Unit
- Connect the white Photocell Signal (PC) conductor from the top-level junction box to the 'CMI PC Input' labelled terminal block in the Control Unit

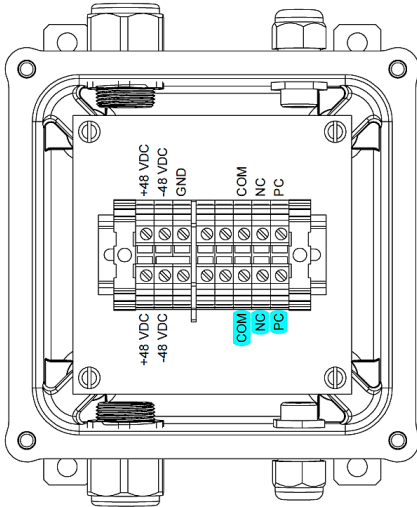

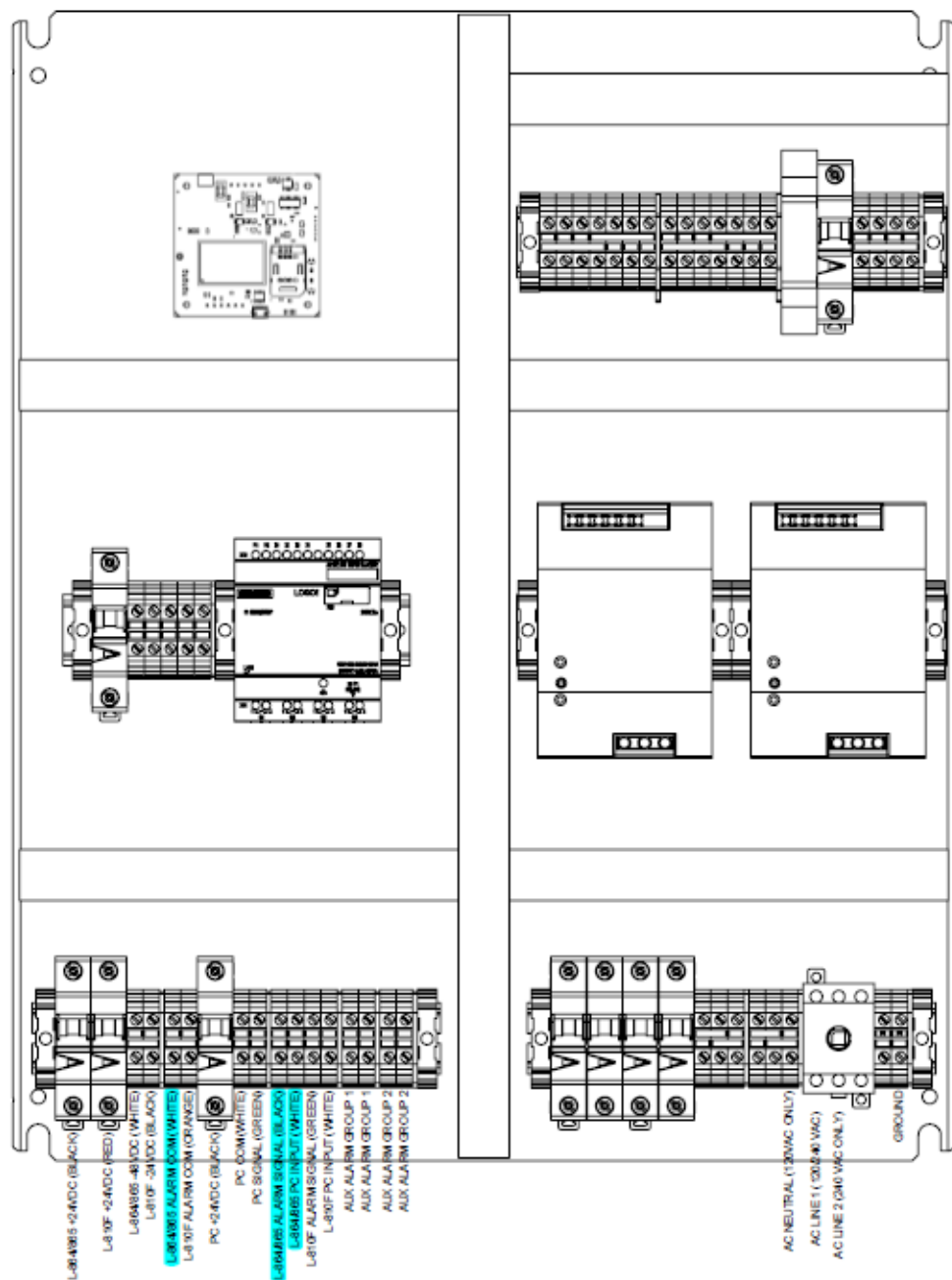

---

9. Mount the LI Single Fixture lights (x3)

Thread a 3/4" pipe thread cord grip to the LI and attach the light to an owner supplied bracket or optional Avlite Right Angle Mounting Bracket (for low intensity fixtures) with a locking nut.

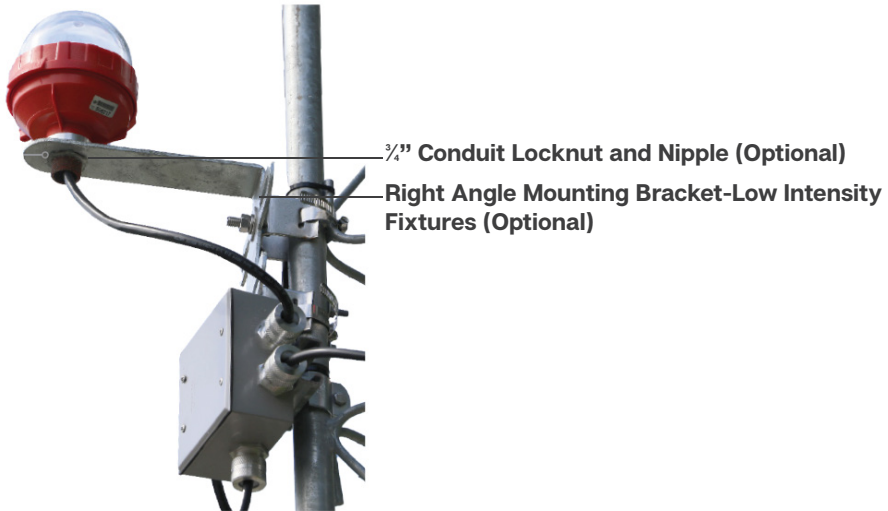

10. Mount middle junction box

**Note:** Mounting hardware for junction boxes is not supplied.



## 11. Wire the LI Single Fixtures lights to the middle junction box.

Wiring instructions-Power and Data cable:

- Connect the red positive conductor from the LI to the appropriately marked +VDC terminal for marker 1,2,3 or 4 (if installed) in the middle junction box

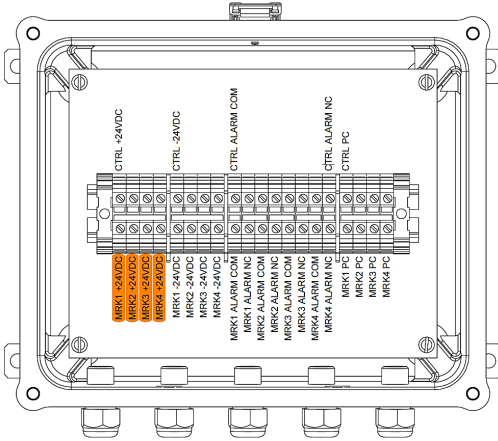

- Connect the black negative conductor from the LI to the appropriately marked -VDC terminal for marker 1,2,3 or 4 (if installed) in the middle junction box

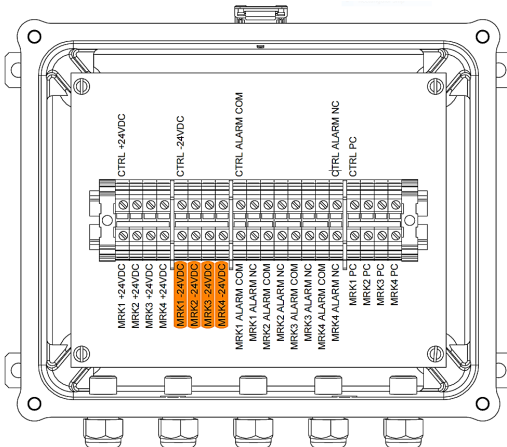



- Connect the orange Alarm COM conductor from the LI to the appropriately marked Alarm COM terminal for marker 1,2,3 or 4 (if installed) in the middle junction box

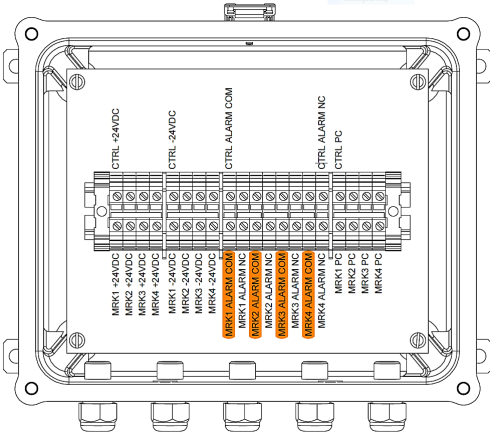

- Connect the Green NC conductor from the LI to the appropriately marked Alarm NC terminal for marker 1,2,3 or 4 (if installed) in the middle junction box

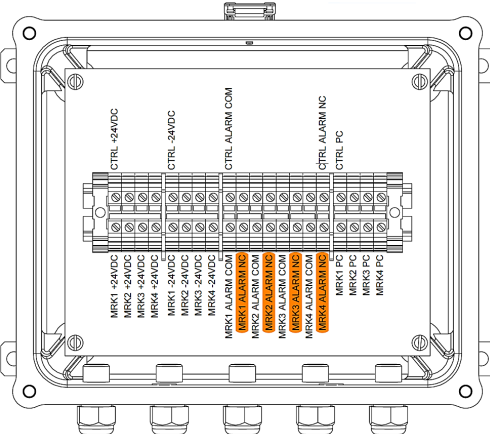



- Connect the White PC Input (IN1) conductor from the LI to the appropriately marked PC terminal for marker 1,2,3 or 4 (if installed) in the middle junction box

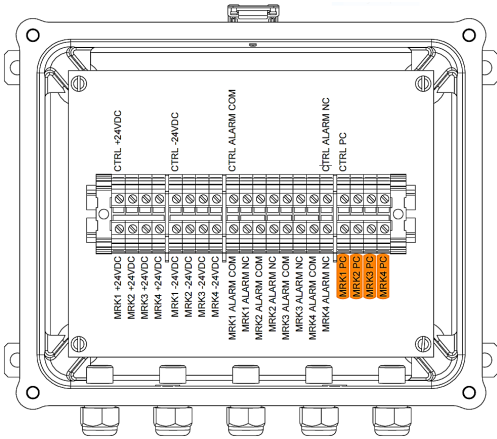

Refer to section 7.2.3 Cabling Requirements for recommended cable sizes.

## 12. Route middle junction box to Control Unit cables

### Wiring instructions-Power and Data Cable:

- Connect the red positive CTRL + 24VDC conductor from the middle junction box to the circuit breaker on the 'LI +24VDC' labelled terminal block in the Control Unit
- Connect the black negative CTRL + -24VDC conductor from the middle junction box to the 'LI -24VDC' labelled terminal block in the Control Unit
- Connect the orange CTRL Alarm COM conductor from the middle junction box to 'LI Alarm Com' labelled terminal block in the Control Unit
- Connect the green CTRL Alarm NC Conductor from the middle junction box to the 'LI Alarm Signal' labelled terminal block in the Control Unit
- Connect the white CTRL PC (IN1) conductor from the middle junction box to the 'LI PC Input' labelled terminal block in the Control Unit

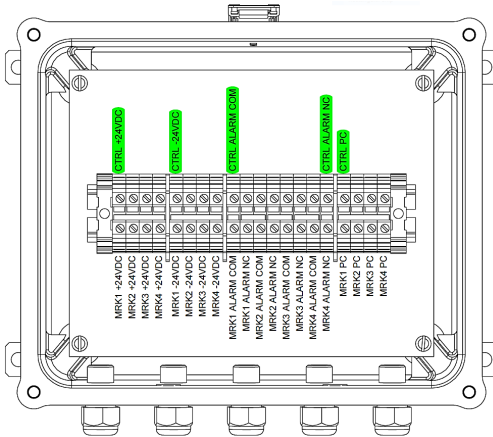

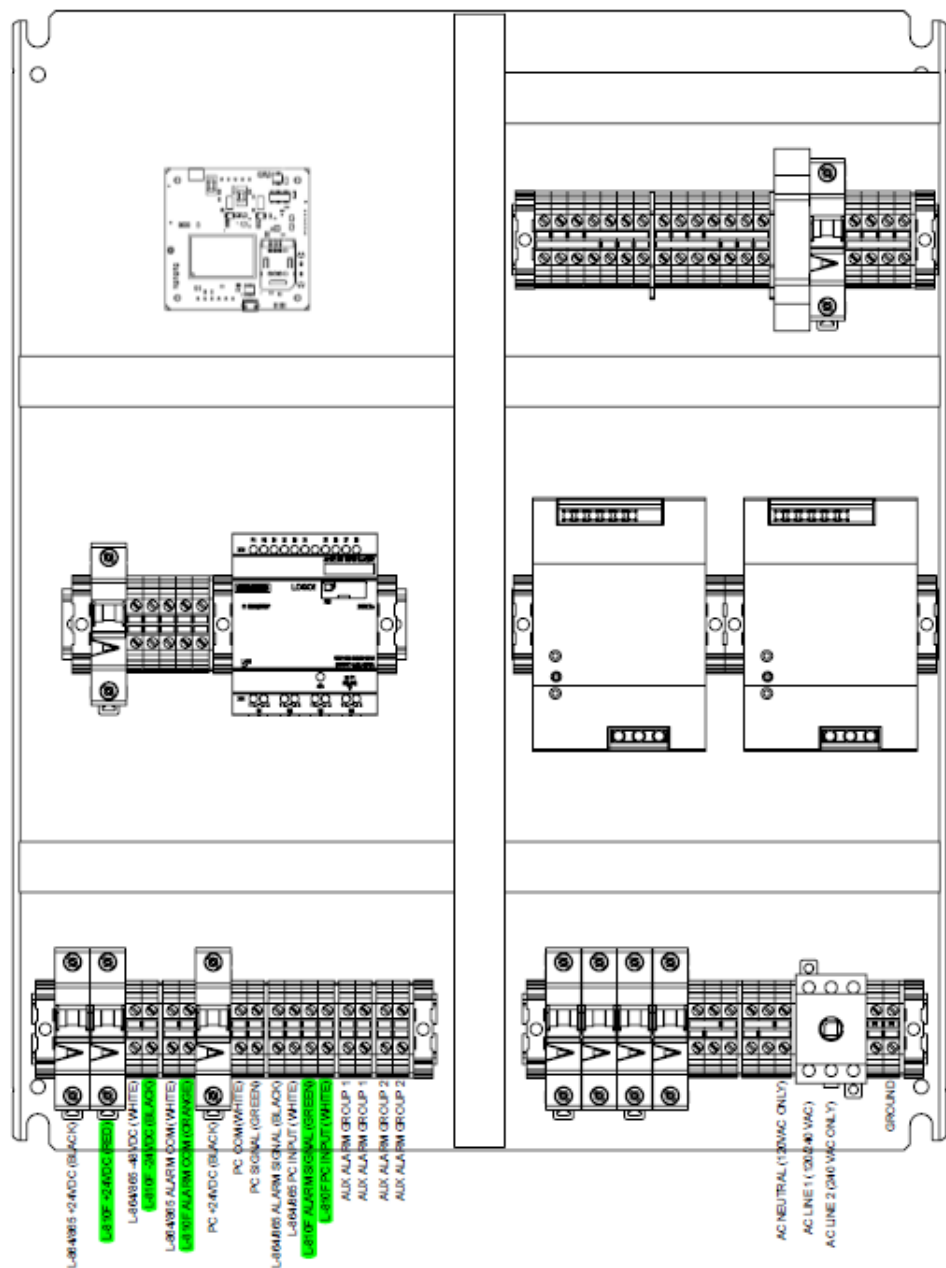

Refer to section 7.2.3 Cabling Requirements for recommended cable sizes.

### 13. Wiring the Control Unit:

#### AC Installation:

Connect the incoming power conductors to the appropriate terminals (AC Neutral, AC Line 1 and AC Line 2) on the power switch in the Control Box.

The grounding conductor will be connected to the green/yellow 'Ground' terminal block adjacent to the power switch.

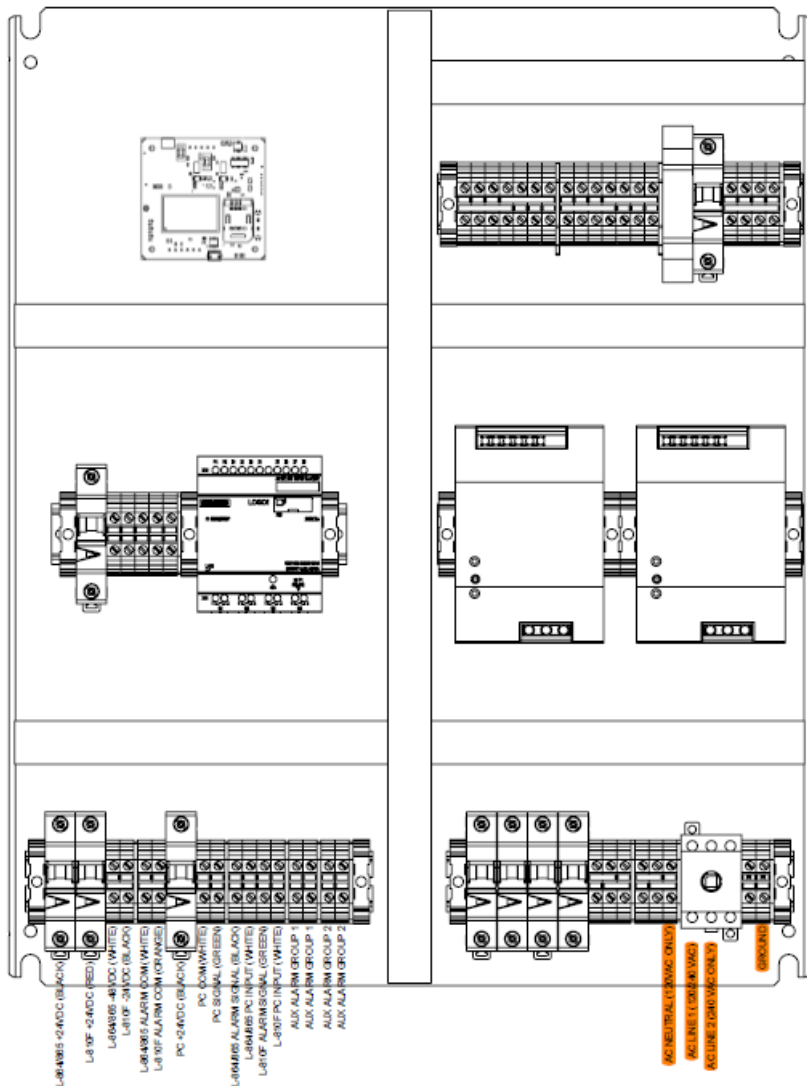



---

### DC Installation:

Connect the positive DC conductor to circuit breaker 1.

Connect the negative conductor to the common terminal block adjacent to the circuit breaker on terminal block 1.

## 7.3 Testing Procedure

**Note:** Avlite recommends that all testing be done during the day.

1. Power the system on.
2. Check that no circuit breakers have tripped.
3. Check the function of all lights (i.e. CMI and all LI lights) during day and night mode by carrying out the following:
  - a. **-Night mode:** Cover the External Photocell and check night operation is functioning as expected. See note below.
  - b. **-Day mode:** Uncover the External Photocell and check day operation is functioning as expected. See note below.
4. Turn the Photocell Bypass Switch to the Night position and check night operation. See note below.
5. Turn the Photocell Bypass Switch back to the Day position and check day operation. See note below.
6. Turn the Photocell Bypass Switch back to the Auto position.
7. For O1 & O2 Variants only:
  - Trip the breaker for the CMI and ensure that the corresponding alarm is received (if monitoring is installed)
  - Trip the breaker for the LI lights and ensure that the corresponding alarm is received (if monitoring is installed)

**Note:**

In Night mode, The CMI should be illuminated red and either flash (for CMI Type A & B) or remain steady-burning (for CMI Type A & C). The LI single fixtures should be illuminated red in the steady-burning configuration.

In Day and twilight mode, the CMI should be illuminated as a white flashing light and all LI fixtures should be off.

## 8.0 Maintenance and Servicing

Refer to the individual light manuals for light maintenance.

Ensure photocell is free from debris (i.e. snow, leaves, etc.) for reliable and continuous operation.

## 9.0 Replacement Parts

If replacement parts are required, please call a local Avlite distributor and reference the Product or Configuration Code called out in the “Product Configuration and Options” section of the corresponding product data sheet.



# 10.0 Troubleshooting

Problem	Possible Cause	Solution
CMI beacon is out (No Alarm)	No power to light	<ul style="list-style-type: none"> <li>• Check for voltage in Control Box.</li> <li>• Check controller to Beacon cable connections at both ends.</li> </ul>
	Junction box wiring	<ul style="list-style-type: none"> <li>• Check junction box wiring.</li> </ul>
CMI beacon is flashing white at night	Photocell input is high	<ul style="list-style-type: none"> <li>• Check wiring.</li> <li>• Confirm there is 0 voltage at the Photocell input.</li> </ul>
	Beacon in “limp mode”	<ul style="list-style-type: none"> <li>• Visually confirm Beacon is flashing at ½ the intensity of normal day mode.</li> </ul>
One LI Single Fixture marker light is out (No Alarm)	Marker wiring	<ul style="list-style-type: none"> <li>• Check the wiring of the malfunctioning lamp.</li> </ul>
	Junction box wiring	<ul style="list-style-type: none"> <li>• Check junction box wiring.</li> </ul>
All marker LI Single Fixtures are out (No Alarm)	Junction box wiring	<ul style="list-style-type: none"> <li>• Check junction box wiring.</li> </ul>
	Cable to junction box	<ul style="list-style-type: none"> <li>• Check controller to junction box cable connections at both ends.</li> <li>• Inspect cable for breaks.</li> </ul>
Light is out	<ul style="list-style-type: none"> <li>• No power to light</li> <li>• Light failure</li> <li>• Light in Alarm Mode</li> </ul>	<ul style="list-style-type: none"> <li>• Physically check connections in junction boxes and control box.</li> <li>• If wiring functions properly, use an alternate power source to check the light.</li> <li>• Replace light if necessary.</li> </ul>
CMI top light is not operational (no white or red mode)	<ul style="list-style-type: none"> <li>• Wired incorrectly or wire(s) lose</li> <li>• Light failure</li> <li>• No power to the light</li> </ul>	<ul style="list-style-type: none"> <li>• Check wiring of light in top junction box and Control Box.</li> <li>• Measure voltage at junction box. If correct input power, replace light.</li> <li>• If no voltage to the junction box, check output power from Control Box.</li> </ul>



<b>Problem</b>	<b>Possible Cause</b>	<b>Solution</b>
LI Single Fixture middle light is not operational (others turning red at night or photocell covered)	<ul style="list-style-type: none"> <li>• Wired incorrectly or wire(s) lose</li> <li>• Light failure</li> </ul>	<ul style="list-style-type: none"> <li>• Check wiring to light in middle junction box</li> <li>• Measure voltage at junction box. If correct voltage replace light.</li> </ul>
LI Single Fixtures are not operational (top light red flashing (or steady-burning) at night or when photocell covered)	<ul style="list-style-type: none"> <li>• Wired incorrectly or wire(s) lose</li> <li>• Light failure</li> <li>• No power to the light</li> </ul>	<ul style="list-style-type: none"> <li>• Check wiring of lights in Middle junction box and Control Box.</li> <li>• Measure voltage at junction box. If correct input power, replace light.</li> <li>• If no voltage to the junction box, check output power from Control Box.</li> </ul>
LI Single Fixtures are not operational (top light white flashing during the day)	<ul style="list-style-type: none"> <li>• Wired incorrectly or wire(s) lose</li> <li>• Photocell failure</li> <li>• PLC failure</li> </ul>	<ul style="list-style-type: none"> <li>• Check wiring between Photocell and PLC, check wiring output of PLC.</li> <li>• Cover photocell. Check if output voltage of PLC changes. If no change, replace Photocell.</li> <li>• If Photocell operational, replace PLC.</li> </ul>
All lights are not operational	<ul style="list-style-type: none"> <li>• No or wrong input voltage</li> <li>• Tripped breaker or no output voltage</li> <li>• Wired incorrectly or lose wire(s)</li> </ul>	<ul style="list-style-type: none"> <li>• Check input power to Control Box.</li> <li>• Check output voltage to both top and middle lights in the Control Box.</li> <li>• Check wiring between Control Box and top and middle junction boxes.</li> </ul>
Light not transitioning between day-night or night-day	<ul style="list-style-type: none"> <li>• Wired incorrectly or wire(s) lose</li> <li>• Photocell failure</li> <li>• PLC failure</li> </ul>	<ul style="list-style-type: none"> <li>• Check wiring between Photocell and PLC, check wiring output of PLC.</li> <li>• Cover photocell. Check if output voltage of PLC changes. If no change, replace Photocell.</li> <li>• If Photocell operational, replace PLC.</li> </ul>



---

# Notes



# Avlite Solution Verticals available



Airfield



Heliport



Obstruction



We believe technology improves navigation™

[avlite.com](http://avlite.com) [info@avlite.com](mailto:info@avlite.com)

**Avlite Systems**  
Australia  
+61 (0)3 5977 6128

**Avlite USA LLC**  
USA  
+1 (603) 737 1311

**Avlite Asia Pte Ltd**  
Singapore  
+65 6908 2917