

FLASH TECHNOLOGY



FTS 350i-2 LED Integrated Beacon

Red LED Obstruction Lighting System

Reference Manual

Part Number F7913502

FRONT MATTER

ABSTRACT

This manual contains information and instructions for installing, operating and maintaining the FTS 350i-2 LED integrated beacon.

COPYRIGHT

©2022, Flash Technology, LLC. All rights reserved.

Reproduction or use of any portion of this manual is prohibited without express written permission from Flash Technology and/or its licensor.

TRADEMARK ACKNOWLEDGEMENTS

Flash Technology® and Vanguard® are registered trademarks of SPX Corporation.

All trademarks and product names mentioned are properties of their respective companies, and are recognized and acknowledged as such by Flash Technology.

APPLICABLE SPECIFICATIONS

The FTS 350i-2 beacon meets or exceeds requirements for an FAA Type L-864 beacon. Additionally, the FTS 350i-2 beacon meets or exceeds requirements for an ICAO Annex 14, Volume 1, 8th Edition Medium-Intensity Type B Obstacle Light.

DISCLAIMER

While every effort has been made to ensure that the information in this manual is complete, accurate and up-to-date, Flash Technology assumes no liability for damages resulting from any errors or omissions in this manual, or from the use of the information contained herein. Flash Technology reserves the right to revise this manual without obligation to notify any person or organization of the revision.

In no event will Flash Technology be liable for direct, indirect, special, incidental or consequential damages arising out of the use of or the inability to use this manual.

WARRANTY

Flash Technology warrants all components, under normal operating conditions, under a 5-year parts replacement warranty.

PARTS REPLACEMENT

The use of parts or components in this equipment that are not manufactured or supplied by Flash Technology voids the warranty and invalidates the third party testing laboratory certification which ensures compliance with FAA Advisory Circulars 150/5345-43J, 150/5345-53D and Engineering Brief No. 67D. The certification is valid as long as the system is maintained in accordance with FAA guidelines (FR doc. 04-13718 filed 6-16-04).

PERSONNEL HAZARD WARNING

DANGEROUS VOLTAGES

Dangerous line voltages reside in certain locations in this equipment. Also, this equipment may generate dangerous voltages. Although Flash Technology has incorporated every practical safety precaution, exercise extreme caution at all times when you expose circuits and components, and when you operate, maintain or service this equipment.

AVOID TOUCHING LIVE CIRCUITS

Avoid touching any component or any part of the circuitry while the equipment is operating. Do not change components or make adjustments inside the equipment with power on.

DO NOT DEPEND ON INTERLOCKS

Never depend on interlocks alone to remove unsafe voltages. Always check circuits with a voltmeter after turning the circuit breakers off. Under no circumstances remove or alter the wiring or interlock switches.

TABLE OF CONTENTS

Front Matter2

 Abstract2

 Copyright2

 Trademark Acknowledgements2

 Applicable Specifications2

 Disclaimer2

 Warranty2

 Parts Replacement2

 Personnel Hazard Warning3

List of Figures5

List of Tables5

Section 1 – Overview6

 1.1 Specifications6

 1.1.1 Regulatory Compliance and Certifications6

 1.2 Beacon Component Identification7

Section 2 – Installation, Unpacking, Mounting, Wiring and Checkout8

 Warning8

 Installation Procedures8

 2.1 Unpack the FTS 350i-28

 2.2 Mount the Beacon8

 2.3 Wiring the Beacon Power and Monitoring Connections10

 2.4 Verifying Operation11

 2.4.1 Power Up11

 2.4.2 Synchronization11

 2.4.3 Check Alarm Status12

 2.4.4 Check Monitoring Status12

Section 3 – Beacon Operation12

 3.1 System Overview12

 3.2 Remote Control Operation12

Section 4 – Maintenance and Troubleshooting14

 4.1 Maintenance14

 4.2 Troubleshooting14

4.3 Beacon Repair Procedures	15
4.3.1 Replace the Beacon.....	15
Section 5 – Customer Support	16
5.1 Contact Information.....	16
5.2 Ordering Parts.....	16
5.3 RMA Policy	16

LIST OF FIGURES

Figure 1-1 – Beacon - External View	7
Figure 1-2 – Beacon Base Assembly	7
Figure 2-1 – Beacon (flashhead) Dimensions and Mounting Outline	9
Figure 2-2 – Mounting Outline with Adapter Bracket	10

LIST OF TABLES

Table 2-1 – Standard Power & Alarm Connections	10
Table 2-2 – Power, Alarm and Radar Interface Connections.....	11
Table 4-1 – Troubleshooting - Beacon is in Alarm	14
Table 4-2 – Troubleshooting - Beacon Does Not Flash at Night	15
Table 4-3 – Troubleshooting – Beacon Flashes, But Not in Sync.....	15
Table 4-4 – Troubleshooting - Beacon Flashes in Daytime	15
Table 5-1 – Optional Parts	16
Table 5-2 – Spare/Replacement Parts	16

SECTION 1 – OVERVIEW

Flash Technology’s FTS 350i-2 is a LED-based, FAA L-864 flashing red beacon. Prewired with power and alarm cables and equipped with an integrated controller, the unit is ready for operation on connection with a customer supplied AC line. The FTS 350i-2 is also available with an optional ADLS compatible radar interface.

The beacon is designed for the safety lighting of wind turbines, towers, flare stacks, chimneys, offshore oil platforms, petrochemical facilities and other obstructions to aerial navigation, as specified by the FAA, FCC, ICAO and Transport Canada. It has been certified to be in compliance with the requirements of each of these organizations.

Shown in [Figure 1-1](#) (page 6), the FTS 350i-2 (hereafter referred to as the beacon) operates from a 100-240 VAC 50/60 Hz AC line. The integrated controller flashes the beacon at night and synchronizes with other Flash Technology beacons via its incorporated GPS receiver/antenna.

28 high performance red LEDs provide the FAA required visible light output. Seven infrared (IR) LEDs ensure visibility of the obstruction light to pilots flying with night vision aids (NVG/NVIS). The combination of red (620nm) LEDs and IR (850nm) LEDs ensures maximum visibility to pilots in all circumstances while providing significant electrical power savings over incandescent fixtures.

The lighting system is equipped with an alarm contact to monitor its operation. Beacon operation, GPS sync and mode change function is monitored with alarms generated for any failure.

This manual provides guidance and recommendations for the installation, inspection and testing of the beacon assembly. Please read this document in its entirety before installing the beacon.

1.1 SPECIFICATIONS

Type	FTS 350i-2: FAA L-864 Red Obstruction Light		
Flash Rate*	20/30 flashes per minute (FPM)		
Intensity	2,000 ± 25% ECD		
AC Voltage	100-240V AC 50/60 Hz		
Power Consumption	Flash rate (200ms flash duration)		
	20 fpm	30 fpm	Standby
	6 Watts	9 Watts	0.5 Watts
Peak VA	100 (during flash)		
Operating Temperature	-40°F to +131°F (-40°C to +55°C)		
Height / Width	4.40" x 9.43" (112mm x 240mm)		
Bolt Hold Down	7.88" (200mm)		
	13.25" (337 mm) (With Adaptor Bracket)		
Weight**	2.9 lb. (1.3 kg); With 50ft of 5 conductor cable: 3.7 lb. (1.7 kg)		
	2.9 lb. (1.3 kg); With 50ft of 10 conductor cable: 6.5 lb. (3 kg)		

* Current FAA regulations require a flash rate of 30 FPM.

1.1.1 REGULATORY COMPLIANCE AND CERTIFICATIONS

- Compliant to Federal Aviation Administration (FAA): AC 150/5345-43J
- Compliant to Canadian Aviation Regulations (CAR): Standard 621
- Compliant to International Civil Aviation Organization (ICAO): Aerodromes, Annex 14, Volume 1, Eighth Edition, dated July 2018 (Medium Intensity, Type B Obstacle Light – Red)

1.2 BEACON COMPONENT IDENTIFICATION

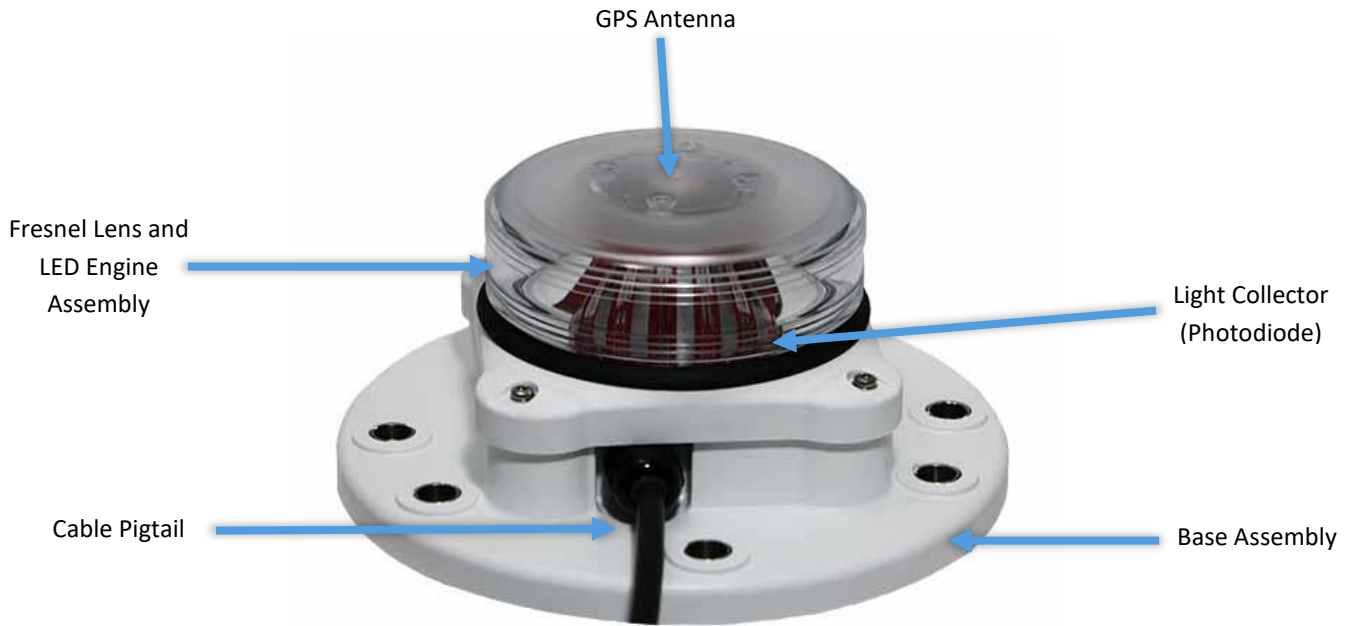

Figure 1-1 – Beacon - External View

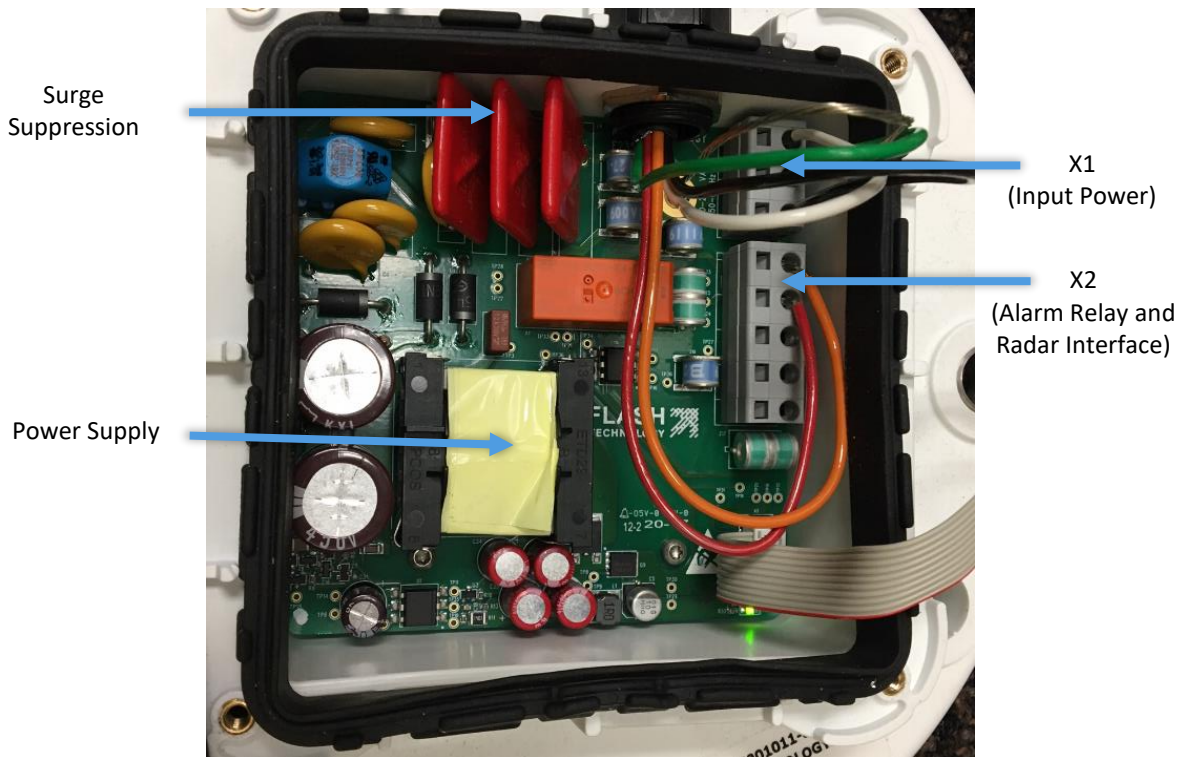

Figure 1-2 – Beacon Base Assembly

SECTION 2 – INSTALLATION, UNPACKING, MOUNTING, WIRING AND CHECKOUT

WARNING

Read the [Personal Hazard Warning](#) (page 3) now. Remove power from all wiring and circuitry before installing or performing work on the beacon. It is the installer's responsibility to comply with all applicable electrical codes.

INSTALLATION PROCEDURES

1. Unpack the FTS 350i-2
2. Mount and level the beacon
3. Wire the beacon power and monitoring connections
4. Verify operation

After all steps are completed successfully, the installation is complete.

2.1 UNPACK THE FTS 350I-2

The FTS 350i-2 is packaged in custom packaging to ensure that it arrives safely and undamaged at the installation location.

Unpack all hardware and inspect for damage. Please contact [Flash Technology Customer Service](#) (page 16) if any parts are damaged or missing. See the [RMA Policy](#) (page 16) for additional information.

2.2 MOUNT THE BEACON

The beacon should be positioned so that the light collector for the photodiode has an unobstructed view of the polar sky. It must be shielded from direct or reflected artificial light that interferes with mode change operation. The GPS antenna located on top of the beacon must have an unobstructed view of the sky for proper reception and synchronization.

The beacon is equipped with 6 mounting holes in the base ([Figure 2-1](#), page 9) laid out on a 7.88-inch (200 mm) bolt circle diameter to enable a 3-hole or a 4-hole mounting pattern of the beacon. The beacon should be mounted directly to the tower pedestal or to an optional mounting bracket¹ utilizing the supplied hardware.

Flash Technology provides 2 options if mounting the beacon to a plate with a 13.25-inch bolt circle:

1. Optional adaptor bracket (F3500100 ADAPTOR BRACKET FTS 350i) ([Figure 2-2](#), page 10).
2. Optional bracket (F3990300 FTS 350i/370i MTG BRKT ASSY UNIVERSAL), designed to fit most wind turbines in the market.

The beacon should be installed level to maintain light output in accordance with FAA/ICAO requirements.

Flash Technology recommends the installation of one or more lightning rods near the beacon. The copper lightning rod(s) should be located approximately 18 inches away from and extend a minimum of 3 feet above the height of the beacon.

¹ Flash Technology provides optional mounting brackets to accommodate various installation configurations and to facilitate leveling of the beacon. Refer to [ordering parts](#) (page 17) for information.

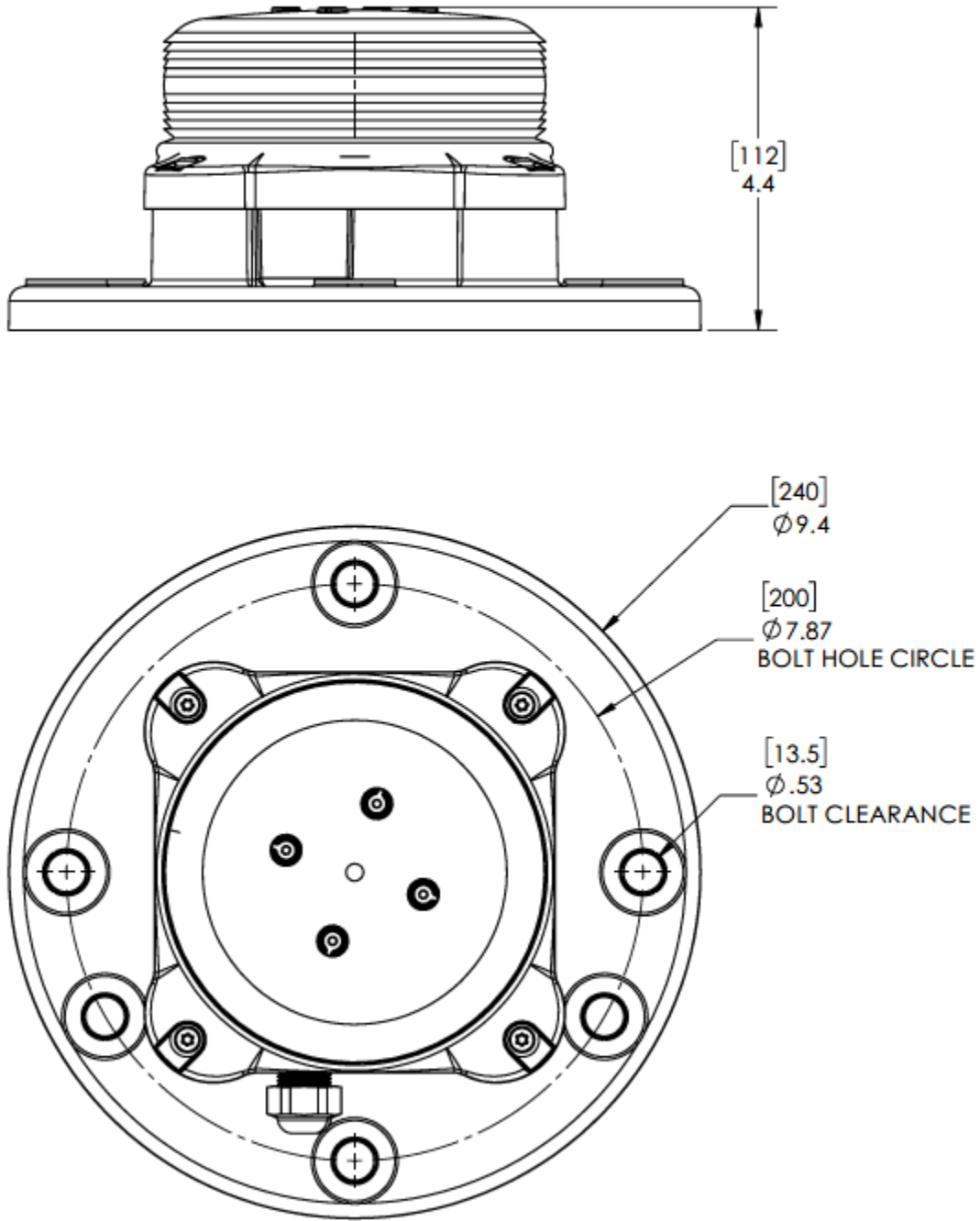

Note: All dimensions are in inches (millimeters in brackets).

Figure 2-1 – Beacon (flashhead) Dimensions and Mounting Outline

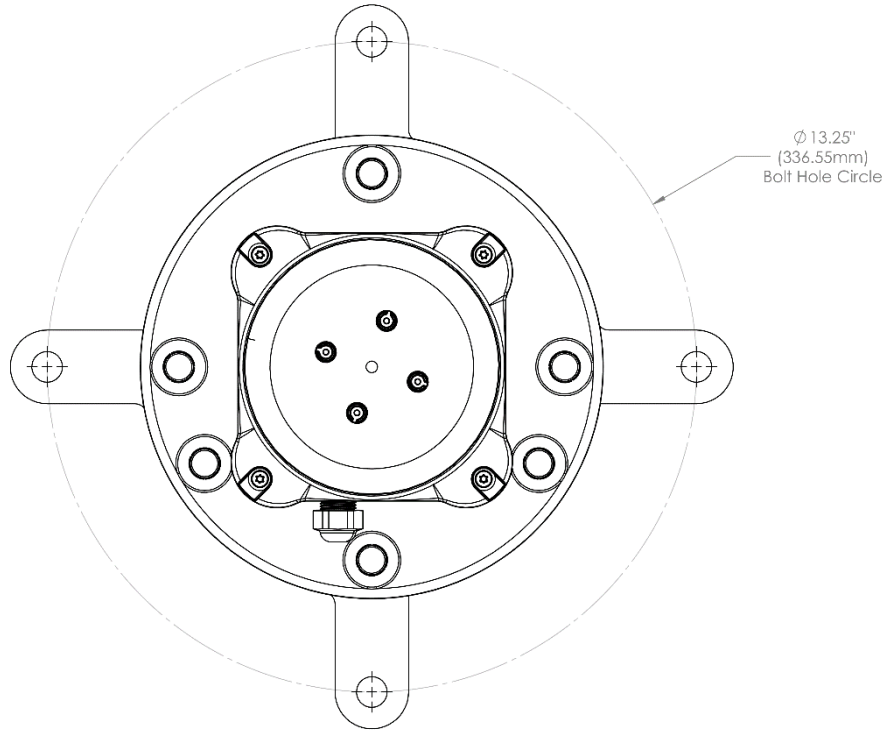

Note: All dimensions are in inches (millimeters).

Figure 2-2 – Mounting Outline with Adapter Bracket

2.3 WIRING THE BEACON POWER AND MONITORING CONNECTIONS

The beacon is supplied with a 50-foot length of power & alarm cable pre-wired to the internal electronics to facilitate installation (see [Table 2-1](#), page 10). The only connections required are power (100-240 VAC, 50/60 Hz) and ground. The ground wire must be connected for proper operation and protection of the beacon. Optional 75-foot, 100-foot and custom cables lengths are available.

Optional dry contact monitoring connections permit monitoring of lighting system operation. The contact is closed when the beacon is operating normally and no fault is detected.

Table 2-1 – Standard Power & Alarm Connections

	Wire Color	Function	Beacon Wiring Connections	External Connections
5 Conductor Cable	Black	Input Power	X1	(120 VAC) - Line (240 VAC) - L1
	White	Input Power		(120 VAC) - Neutral (240 VAC) - L2
	Green	Ground		Ground
	Red	Alarm Contact	X2	Alarm Input ²
	Orange	Alarm Contact		Alarm Input ²

² Refer to the monitoring system manufacturer’s installation manual for connection locations

In the event the beacon is purchased for use in conjunction with an Aircraft Detection Lighting System (ADLS) radar, the beacon is supplied with a 10-conductor, pre-wired, power and alarm cable (see [Table 2-2](#), page 11). The beacon is connected to a Light Controlling Module (LCM) like Flash Technology’s FTC 370 or similar radar interface device. Refer to the LCM wiring diagram for information on connections.

Table 2-2 – Power, Alarm and Radar Interface Connections

	Wire Color	Function	Beacon Wiring Connections	External Connections
10 Conductor Cable	Black	Input Power	X1	(120 VAC) - Line (240 VAC) - L1
	White	Input Power		(120 VAC) - Neutral (240 VAC) - L2
	Green	Ground		Ground
	Red	Alarm Contact	X2	Alarm Input ³
	Orange	Alarm Contact		Alarm Input ³
	Brown	Radar Inhibit Input		Control Output ⁴
	Blue	Radar Inhibit Input		Control Output ⁴
	Violet		Cut wire back, do not use.	
	Yellow		Cut wire back, do not use.	
	Gray		Cut wire back, do not use.	
	Bare Drain		Cut wire back, do not use.	

2.4 VERIFYING OPERATION

Apply power to the beacon and verify operation.

2.4.1 POWER UP

When powered up, the beacon will begin flashing after several seconds. The beacon will continue to flash for 15 minutes. After the initial 15 minutes, the unit will stop flashing once the photodiode detects sufficient light for 30 seconds.

2.4.2 SYNCHRONIZATION

For synchronization to occur, the GPS antenna (located in top section of the beacon) must have an unobstructed view of the sky. As long as 5 minutes may be required for the beacon to achieve a GPS signal lock. If GPS synchronization is not established within 5 minutes of power-on, a GPS Sync Alarm is established. Following this initial power up check, the GPS Sync Alarm will only activate if synchronization has been lost for over 1 hour.

Note: The alarm will clear once a GPS signal is locked. Refer to Section 4 if the Sync Alarm remains on for more than 15 minutes.

³ Refer to the monitoring system manufacturer’s installation manual for connection locations

⁴ Refer to the radar interface manufacturer installation manual for connection locations

2.4.3 CHECK ALARM STATUS

VIA REMOTE CONTROL AND STATUS FLASHES

After 5 minutes of operation, check the alarm status using the remote control. Point the remote control, within 20 feet of the beacon, and press the “1” button. If there are no alarm conditions, the unit will respond with a single quick blink. If multiple quick blinks are observed, refer to [Troubleshooting](#) (page 14).

VIA ALARM RELAY

After 5 minutes of operation, check the alarm contact to ensure there are no alarm conditions. A multi-meter may be used to check for continuity between the COM (Red) and NC (Orange) conductors. The contact is closed when the beacon is powered, operating normally and no fault is detected. If an alarm condition is observed, refer to [Troubleshooting](#) (page 14).

2.4.4 CHECK MONITORING STATUS

Confirm monitoring status by disconnecting power to the beacon. This should create an alarm.

SECTION 3 – BEACON OPERATION

3.1 SYSTEM OVERVIEW

The standard 5-conductor power and alarm cable provides connection for the AC line (3 wires) and alarm monitoring connections (2 wires). See [beacon wiring instructions](#) (page 10). The optional 10-conductor cable provides the same connections and adds connections for the auxiliary control input (2 wires).

The AC input power requirement is 100-240 VAC 50/60Hz. The dry contact alarm connection is closed when the beacon is operating normally and no fault is detected.

The beacon senses ambient light using a photodiode. This determines night mode and enables the LED beacon flash. A GPS antenna and integrated receiver permit synchronization with other beacons. The Driver PCB detects alarm conditions including beacon failure, photodiode alarm and synchronization fault.

The LED engine assembly contains high-performance RED and INFRARED (IR) LEDs, which illuminate when powered by the Driver PCB.

The power supply, with surge suppressors, are located in the base of the beacon. The power supply generates the proper DC current to the Driver PCB when AC line voltage is applied at its input. The surge suppressors provide protection from incoming lightning and transient voltage induced surges.

3.2 REMOTE CONTROL OPERATION

When purchasing the FTS 350i-2 beacons in sets of 1-10, a single remote control is included (1 beacon = 1 remote, 2 beacons = 1 remote, 3 beacons = 1 remote etc...). Additional remote controllers may be ordered (PN 11000017081) to assist with installation, configuration and troubleshooting. The remote control has the following functionality:

FTS 350i-2 USER MANUAL

Remote Button	Action	Description / Notes
PWR	Toggle between Red Night (Flashing ON) and Day (Flashing OFF) 30 min overrides	On a unit powering up, the 1st button press triggers red night override.
1	Verify alarm state 1 blink = status ok 2 blinks = flash alarm (red or IR) 3 blinks = GPS sync alarm 4 blinks = PD alarm	If more than 1 alarm is active, then the alarm highest in that hierarchy will show. Ex: Red flash alarm + PD alarm will cause 2 blinks.
2	Toggle flash rate <u>FPM = Flashes per minute</u> 30 FPM = Current FAA standard 20 FPM = Sync with existing installations and/or previous FAA standard	Pressing button 2 will show the current flash rate: <ul style="list-style-type: none"> • 1 blink for 20 fpm • 2 blinks for 30 fpm Pressing 2 again within 15 seconds will toggle the setting. Ex: If it was set to 20 fpm, then the fpm will now be set to 30 and the beacon will provide 2 blinks to indicate the new setting.
3	Toggle PD alarm disable <u>PD = Photodiode</u> Enabled = Alarm will active after 19 hours without a mode change Disabled = PD alarm functions are turned OFF (for areas that experience extended day/nighttime conditions)	Pressing button 3 will show the current PD Alarm setting: <ul style="list-style-type: none"> • 1 blink for PD Alarm Enabled • 2 blinks for Disabled Pressing 3 again within 15 seconds will toggle the setting. Ex: If it was set to PD Alarm Enabled, then the PD Alarm will become Disabled and the beacon will provide 2 blinks to indicate the new setting.
4	Toggle PD disable (24hr red mode) <u>PD = Photodiode</u> Enabled = Auto ON and OFF (based on FAA regulations for light levels) Disabled = 24 Hour ON red flashing	Pressing button 4 will show the current PD Defeat setting: <ul style="list-style-type: none"> • 1 blink for PD Defeated • 2 blinks for PD Engaged Pressing 4 again within 15 seconds will toggle the setting. Ex: If it was set to PD Defeated, then the PD will become engaged and the beacon will provide 2 blinks to indicate the new setting.
5	Toggle GPS sync alarm disable GPS = Global positioning system Enabled = Alarm will activate if unable to find enough satellites Disabled = GPS alarm functions are turned OFF	Pressing button 5 will show the current GPS Alarm setting: <ul style="list-style-type: none"> • 1 blink for GPS Alarm Enabled • 2 blinks for Disabled

FTS 350i-2 USER MANUAL

		Pressing 5 again within 15 seconds will toggle the setting. Ex: If it was set to GPS Alarm was Enabled, then the GPS Alarm will become Disabled and the beacon will provide 2 blinks to indicate the new setting.
6	N/A	Factory reserved, not used.
7	N/A	Factory reserved, not used.
8	Toggle lighting inspection (LI)	The lighting inspection mode will inhibit normal flashing and tests that the monitoring features cause red and IR flash alarms. Pressing 8 again will restore the beacon to normal operation and clear the alarms.
9	Blink out configuration over ~12 seconds	20/30 fpm (1/2 blinks), 2s pause, PD Alarm Enabled/Disabled (1/2 blinks), 2s pause, PD Defeat Enabled/Disabled (1/2 blinks), 2s pause, GPS Sync Alarm Enabled/Disabled (1/2 blinks)
0	Cancel any override in progress	Cancel any mode override from the PWR button and the Induced LI flash alarms from button 8. Also cancels the 15 min forced red mode on power up.

SECTION 4 – MAINTENANCE AND TROUBLESHOOTING

4.1 MAINTENANCE

No regularly scheduled maintenance is required for the beacon.

- Flash Technology warrants the light output of the beacon to meet or exceed FAA/ICAO requirements for a 5-year period.
- Periodic cleaning of the lens is recommended. Use soapy water or any acrylic cleaning solution. No other cleaning solutions are recommended. Abrasive compounds will scratch the lens.
- Optional mounting brackets and cable glands should be checked periodically for tightness.

4.2 TROUBLESHOOTING

Follow the troubleshooting steps in the tables below as applicable. Beacon repair procedures are provided in [Section 4.3](#) (page 15).

Table 4-1 – Troubleshooting - Beacon is in Alarm

Step	Check/Test/Action		Action
1a	Is beacon flashing at night?	Yes No	Go to Step 1b. Go to Step 2a.
1b	Is beacon flashing in sync with other FTS 350i-2 beacons?	Yes No	Go to Step 1c. Go to Step 3.
1c	Does beacon flash in daytime?	Yes No	Go to Step 4. Beacon is operational.

Table 4-2 – Troubleshooting - Beacon Does Not Flash at Night

Step	Check/Test/Action		Action
2a	Is AC power applied?	Yes No	Go to Step 2b. Correct problem.
2b	Does beacon flash after being covered for 1 minute?	Yes No	Go to Step 2c. Replace unit.
2c	Is there continuity between the RED and ORANGE conductors? --OR-- Does the beacon respond with a single quick blink to a button press of 1 on the remote control?	Yes No	Beacon is operational. Replace the unit.

Table 4-3 – Troubleshooting – Beacon Flashes, But Not in Sync

Step	Check/Test/Action		Action
3a	Does GPS antenna (located in top of beacon) have an unobstructed view of the sky? See Section 2.1	Yes No	Go to Step 3b. Correct problem.
3b	After 10 minutes of power on, is there continuity between the RED and ORANGE conductors? --OR-- Does the beacon respond with a single quick blink to a button press of 1 on the remote control?	Yes No	Beacon is operational. Replace the unit

Table 4-4 – Troubleshooting - Beacon Flashes in Daytime

Step	Check/Test/Action		Action
4	Is the light collector (located near marked corner of beacon) obstructed? Check for any foreign matter on top of beacon.	Yes No	Correct problem Replace unit

4.3 BEACON REPAIR PROCEDURES

Warning: Read the [Personnel Hazard Warning](#) (page 3) now. Remove power from all wiring and circuitry before installing or performing work on the beacon. It is the responsibility of the installer to comply with all applicable electrical codes.

Note: While performing the following steps, check for any loose connections and other damaged components.

4.3.1 REPLACE THE BEACON

FTS 350i-2 Part Number: F1350200

BEACON REMOVAL

Disconnect the beacon’s cable pigtail from the power source and any monitoring equipment. Unfasten the hardware that holds the 350i unit to the structure or mounting bracket. Remove the beacon.

BEACON REPLACEMENT

Refer to [Section 2](#) (page 8).

SECTION 5 – CUSTOMER SUPPORT

5.1 CONTACT INFORMATION

Customer Service: 1-800-821-5825

Telephone: (615) 503-2000

Fax: (615) 261-2600

Website: flashtechnology.com

Shipping Address:

Flash Technology
332 Nichol Mill Lane
Franklin, TN 37067

5.2 ORDERING PARTS

To order spare, replacement or optional parts, contact Inside Sales at 1-800-821-5825.

Table 5-1 – Optional Parts

Description	Part Number
KIT MOUNTING BRACKET FTS 350i-2	1350140
ADAPTOR BRACKET FTS 350i-2	3500100
FTS 350i/370i MTG BRKT ASSY UNIVERSAL	11000017307
FLASHHEAD GE SPECIFIC MTG BRKT ASSY1.5MW	3991220
REMOTE CONTROL UNIT RC-18A FTS 350i	11000017081

Table 5-2 – Spare/Replacement Parts

Description	Part Number
FTS 350i-2 INTEGRATED LED BEACON	1350200

5.3 RMA POLICY

If any system or part(s) purchased from Flash Technology needs to be returned for any reason (subject to the warranty policy), please see the current RMA policy available online at flashtechnology.com/rma

To initiate an RMA, call the Flash Technology Technical Support at 1-800-821-5825, option 9. Tech Support is available M-F, 7 a.m. to 7 p.m. CT.

Emailing a completed RMA request form to FlashSupport@spx.com can also start the process on sites not requiring detailed troubleshooting. Complete the online form at flashtechnology.com/rma-request-form

NOTE: An RMA number must be requested from Flash Technology prior to return of any product. No returned product will be processed without an RMA number. Failure to follow the below procedure may result in additional charges and delays. Any product received without an RMA number is subject to return back to the sender. All RMA numbers are valid for 30 days.