



SERIAL NUMBER



FTB 360i LED Integrated Beacon

**Reference Manual
Part Number 791360**

Flash Technology, 332 Nichol Mill Lane, Franklin, TN 37067
(615) 261-2000

Front Matter

Abstract

This manual contains information and instructions for installing, operating and maintaining the FTB 360i LED Integrated L-864 Beacon.

Copyright

Copyright © 2009, Flash Technology®, Franklin, TN, 37067, U.S.A.

All rights reserved. Reproduction or use of any portion of this manual is prohibited without express written permission from Flash Technology and/or its licensor.

Trademark Acknowledgements

Flash Technology® is a registered trademark name.

ElectroFlash™, Flash Tech™, Flash Technology™, FTCA™, Flash™ and the Flash Technology Logo are all trademarks of Flash Technology.

All trademarks and product names mentioned are properties of their respective companies and are recognized and acknowledged as such by Flash Technology.

Disclaimer

While every effort has been made to ensure that the information in this manual is complete, accurate and up-to-date, Flash Technology assumes no liability for damages resulting from any errors or omissions in this manual, or from the use of the information contained herein. Flash Technology reserves the right to revise this manual without obligation to notify any person or organization of the revision.

In no event will Flash Technology be liable for direct, indirect, special, incidental, or consequential damages arising out of the use of or the inability to use this manual.

Warranty

Flash Technology warrants all components, under normal operating conditions, for 5 years.

Table of Contents

FTB 360i LED Integrated Beacon	i
Front Matter	ii
Abstract	ii
Copyright	ii
Trademark Acknowledgements	ii
Disclaimer	ii
Warranty	ii
Table of Contents	iii
List of Figures	iv
List of Tables	iv
Section 1 - Overview	1
Section 2 – Installation – Mounting, Wiring, and Checkout	2
2.1 Mounting the Beacon	2
2.2 Wiring the Beacon	3
2.3 Verifying Operation	4
2.3.1 Power up	4
2.3.2 Synchronization Underway	4
2.3.3 Synchronization Complete	4
Section 3 - Operation	5
3.1 Indicators and Configuration	5
Section 4 - Beacon Theory of Operation	6
4.1 System Overview	6
Section 5 - Maintenance and Troubleshooting	7
5.1 Maintenance	7
5.2 Troubleshooting	8
5.3 Beacon Repair Procedures	9
5.3.1 Replacing the Top Plate Assembly (11000003426)	9
5.3.2 Replacing the Bottom Plate Assembly (11000003427)	10
5.3.3 Replacing the LED Module (11000001991)	12
5.4 Customer Service	16
5.5 Ordering Parts	16
Section 6 – Specifications	17
Section 7 – Regulatory Compliance and Certifications	17
Return Material Authorization (RMA) Policy	18
Return to Stock Policy	18

List of Figures

Figure 1-1 – FTB 360i Flashing Red Beacon with Pre-Wired Power & Alarm Cable	1
Figure 2-1 – Beacon - Bottom View.....	2
Figure 3-1 – Beacon Configuration and Indicators	5
Figure 4-1 – Beacon Wiring Diagram	6
Figure 5-1 – Beacon - External View	13
Figure 5-2 – Cast Latch Pad	13
Figure 5-3 – Beacon - Exploded View	14
Figure 5-4 – Bottom Plate Assembly (11000003427) - Component Location.....	15

List of Tables

Table 2-1 – Power & Alarm Connections	3
Table 2-2 – Beacon and LED States – Day Mode.....	4
Table 2-3 – Beacon and LED States – Night Mode	4
Table 3-1 – Configuration Jumpers	5
Table 3-2 – Status LED's.....	5
Table 3-3 – Alarm LED's	5
Table 5-1 – Troubleshooting - Beacon is in Alarm	8
Table 5-2 – Troubleshooting - Beacon does not Flash at night.....	8
Table 5-3 – Troubleshooting - Beacon flashes but not in sync	8
Table 5-4 – Troubleshooting - Beacon flashes in daytime	8
Table 5-5 – Optional Parts	16
Table 5-6 – Spare/Replacement Parts.....	16

Section 1 - Overview

The Flashing Red Beacon is designed for the lighting of wind turbines, towers, flare stacks, chimneys, offshore oil platforms, petrochemical facilities and other obstructions to aerial navigation, as specified by the FAA, FCC, ICAO and Transport Canada.

The FTB 360i LED Integrated L-864 Flashing Red Beacon as shown in Figure 1-1, (hereafter referred to as the Beacon) is pre-wired with a power & alarm cable and operates from 120-240VAC 50/60 Hz. The only required customer connection is the AC Line as the Beacon incorporates an integrated controller which flashes the Beacon at Night and provides synchronization to other Beacons. Alarm contacts are available for operation monitoring. The beacon consists of 42 High Performance LED's that provide the light output equivalent to an incandescent fixture while consuming a fraction of the electrical power.

This manual provides guidance and recommendations for the installation and checkout of the beacon assembly. Please read this document in its entirety before installing the Beacon.



Figure 1-1 – FTB 360i Flashing Red Beacon with Pre-Wired Power & Alarm Cable

Section 2 – Installation – Mounting, Wiring, and Checkout

Warning

Remove power from all wiring and circuitry before installing or working on the Beacon.

Installation Procedure:

1. Mount the Beacon (Section 2.1)
2. Wire the Beacon Power (Section 2.2)
3. Verify Operation (Section 2.3)
4. Wire the Beacon Monitoring Connections (Section 2.2)
5. Confirm monitoring status by disconnecting power to the Beacon. This should create an alarm.

After all steps are completed successfully, the installation is complete.

2.1 Mounting the Beacon

We recommend the installation of one or more lightning rods near the installed Beacon. The lightning rods should extend a minimum of three feet above the height of the Beacon.

The Beacon should be positioned so that the Photocell (see Figure 3-1) points to the North and has an unobstructed view of the polar sky. Also, it must not view direct or reflected artificial light. The GPS antenna located on top of the Beacon must have an unobstructed view of the sky for proper reception and synchronization.

The Beacon is mounted to the tower pedestal utilizing supplied hardware. Six mounting holes are provided on the Beacon base (Figure 2-1). These mounting holes will align with most tower pedestals. The Beacon should be installed level to maintain light output in accordance with FAA requirements.

An optional mounting bracket (PN 3991210) is available to accommodate various installation configurations and to facilitate leveling the beacon. See Section 5.5 for ordering information.

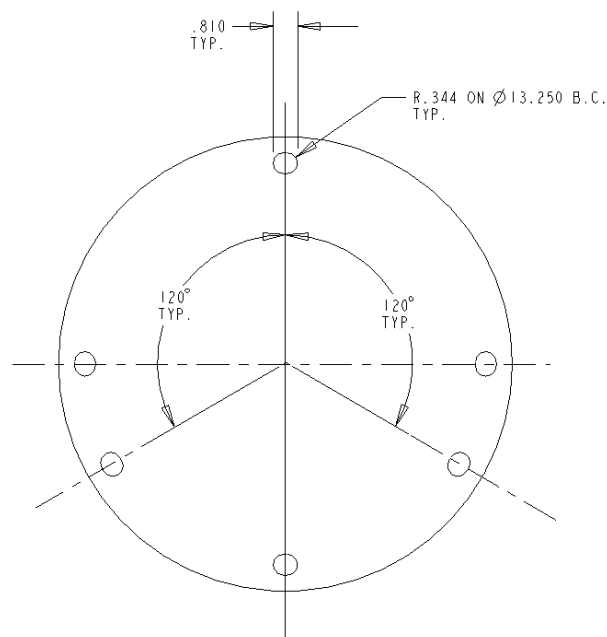

Figure 2-1 – Beacon - Bottom View

2.2 Wiring the Beacon

The Beacon is supplied with a 50 foot power & alarm cable pre-wired to the internal electronics to facilitate installation. The only connection required is power (120-240 VAC, 50/60 Hz) and ground. The ground wire must be connected for proper operation and protection of the Beacon. The two dry contact Monitoring connections permit monitoring of Beacon operation and are closed when the Beacon is operating normally and no fault is detected.

Table 2-1 – Power & Alarm Connections

Terminal	Wire Color
Power – (120V: Line / 240V: L1)	Black
Power – (120V: Neutral / 240V: L2)	White
Power – Earth Ground	Green
Monitoring – Common	Red
Monitoring – Normally Closed	Orange

2.3 Verifying Operation

Apply power to the Beacon and verify operation as indicated by the Beacon and Indicator LED's as shown in Table 2-2 and 2-3. More information on the LED indicators is provided in Section 3.1.

Table 2-2 – Beacon and LED States – Day Mode

	Beacon	Indicator LED's					
		STATUS			ALARM		
		PWR	MODE	SYNC	LED	PEC	SYNC
1. Power Up (10 seconds)	ON	ON	ON	ON	ON	ON	ON
2. Synchronization underway	OFF	ON	OFF	OFF	OFF	OFF	OFF
3. Synchronization complete	OFF	ON	OFF	ON	OFF	OFF	OFF

Table 2-3 – Beacon and LED States – Night Mode

	Beacon	Indicator LED's					
		STATUS			ALARM		
		PWR	MODE	SYNC	LED	PEC	SYNC
1. Power Up (2 seconds)	ON	ON	ON	ON	ON	ON	ON
2. Synchronization underway	FLASH	ON	FLASH	OFF	OFF	OFF	OFF
3. Synchronization complete	FLASH	ON	FLASH	ON	OFF	OFF	OFF

2.3.1 Power up

If powered up during the Day (photocell detects sufficient light), the Beacon and all Indicator LED's are turned on for 10 seconds, providing easy verification of operation during install. Verify that the Beacon is on during this time.

If powered up at Night, the Beacon and LED's are initially turned on for only 2 seconds.

2.3.2 Synchronization Underway

Following power up in daytime, the Beacon should be off. At nighttime, the Beacon and the MODE status LED flash at a rate of 20 flashes per minute. The PWR status LED should be on and all Alarm LED's should be off.

After power up or power loss, as much as 15 minutes may be required for synchronization. Synchronization is not complete while the SYNC status LED is off. For synchronization to occur, the GPS antenna located on top of the Beacon must have an unobstructed view of the sky.

2.3.3 Synchronization Complete

When synchronization is complete, the SYNC status LED will be on solid. This is the normal operating condition.

Section 3 - Operation

3.1 Indicators and Configuration

Located on top of the Beacon are Configuration Jumpers, LED Indicators, and the Photocell. A description of each is provided below. See Section 2.3 for more information on the Status LED's.

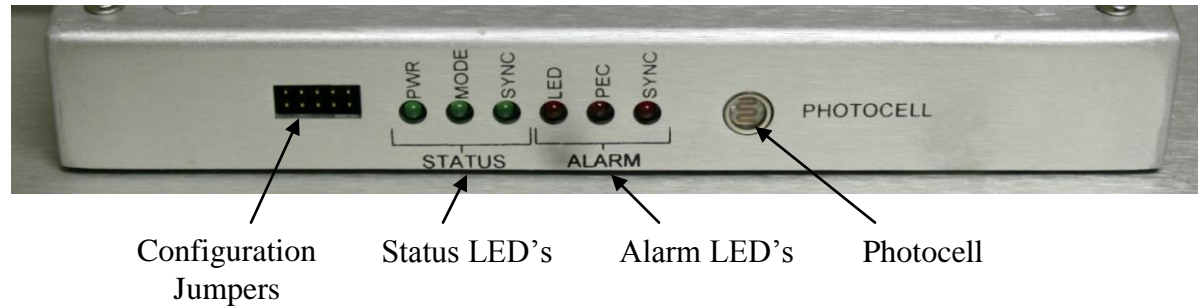

Figure 3-1 – Beacon Configuration and Indicators

Table 3-1 – Configuration Jumpers

To configure a particular option, move the spare jumper shunt to the specified location. See the Dome Removal and Dome Reassembly procedures in Section 5.

PEC DEFEAT	DELAY	NOT USED	MANUAL DAY	MANUAL NIGHT
Disables photocell Alarm	Provides Sync with Orga L350-864-G ¹	Holds Spare Jumper Shunt	Forces Day operation	Forces Night operation

(1) Flash Technology will NOT be responsible for any changes to GPS sync response by other manufacturers.

Table 3-2 – Status LED's

Name	Function
PWR	On indicates the Beacon is powered.
MODE	Flashes on corresponding to the Beacon flash; Off during the day.
SYNC	On indicates proper GPS synchronization. After power up, 15 minutes may be required for synchronization.

Table 3-3 – Alarm LED's

Name	Function
LED	On indicates insufficient or no current drawn by the Beacon LED Power Supply and LED Module when flashed.
PEC	On indicates no transition between day and night sensed by the photocell for an extended period (Day > 19 hours, Night > 5 days)
SYNC	On indicates flashing of the Beacon is not synchronized.

PHOTOCELL

The Photocell senses day and night light levels for beacon mode control per FAA guidelines.

Section 4 - Beacon Theory of Operation

4.1 System Overview

The Beacon block diagram is shown in Figure 4-1.

The Customer Connection Power & Alarm Cable provides connection of the AC Line (3 wires) and Alarm monitoring connections (2 wires). The AC Line may be 120-240VAC 50/60Hz. The dry contact Alarm connections are closed when the Beacon is operating normally and no fault is detected.

The LED Module (11000001991) contains the 42 High Performance LED's which light when powered by the LED Power Supply.

The Bottom Plate Assembly (11000003427) contains the Surge Suppressor, LED Power Supply, and Harness. The Surge Suppressor, wired directly across the AC Line, provides protection from incoming Lightning and transient voltage induced surges. The LED Power Supply generates the proper DC current to the LED Module (11000001991) when AC line voltage is applied at its input.

The Top Plate Assembly (11000003426) contains the Beacon Controller. The Controller senses ambient light with a Photocell and at night flashes the LED Beacon by connecting AC line voltage to the LED Power Supply. A GPS antenna and receiver permit synchronization to other Beacons. The Controller detects alarm conditions including Beacon failure, Photocell alarm, and Synchronization fault. Status and Alarm LED's are provided to permit easy determination of proper operation and fault diagnosis.

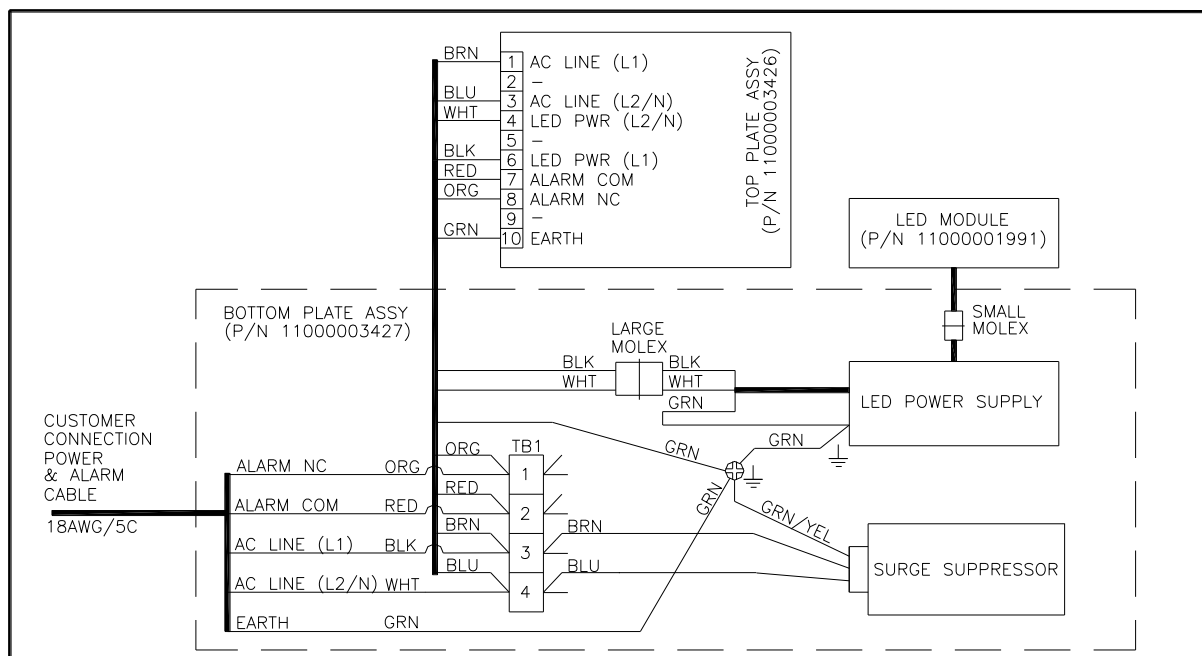

Figure 4-1 – Beacon Wiring Diagram

Section 5 - Maintenance and Troubleshooting

5.1 Maintenance

No regularly scheduled maintenance is required for the Beacon.

- Flash Technology warranties the light output of the Beacon to meet or exceed FAA requirements for a 5 year period. LED Module replacement after 5 years is recommended to insure FAA compliance. See Section 5.3.3.
- General cleaning of the Dome Assembly is recommended after re-lamping with regular glass cleaning solution, soapy water or any acrylic cleaning solutions. No other cleaning solutions are recommended. Abrasive compounds will scratch the Dome Assembly.

5.2 Troubleshooting

Follow the troubleshooting steps in the tables below as applicable. Beacon Repair Procedures are provided in Section 5.3

Table 5-1 – Troubleshooting - Beacon is in Alarm

Step	Check/Test/Action		Action
1.a	Is Beacon Flashing at night?	Yes No	Go to Step 1.b Go to Step 2.a
1.b	Is Beacon flashing in sync with other FTB 360i beacons? Check Beacon SYNC Status and SYNC Alarm LED's.	Yes No	Go to Step 1.c Go to Step 3.a
1.c	Is Beacon PEC Alarm LED on? Does Beacon flash in daytime?	Yes No	Go to Step 4.a

Table 5-2 – Troubleshooting - Beacon does not Flash at night

Step	Check/Test/Action		Action
2.a	Is AC Power applied? Measure at Beacon terminals (Section 2.1)	Yes No	Go to Step 2.b Correct problem.
2.b	Is the photocell positioned correctly? Check installation (Section 2.2)	Yes No	Go to Step 2.c Correct problem.
2.c	Is Beacon <u>PWR</u> Status LED on?	Yes No	Go to Step 2.d Replace Beacon Top Plate Assembly (See Section 5.3.1)
2.d	Is Beacon <u>MODE</u> Status LED flashing?	Yes No	Go to Step 2.e Replace Beacon Top Plate Assembly (See Section 5.3.1)
2.e	Is Beacon <u>LED</u> Alarm LED on ?	Yes No	Replace Beacon Bottom Plate Assembly (See Section 5.3.2) Replace Beacon Top Plate Assembly (See Section 5.3.1)

Table 5-3 – Troubleshooting - Beacon flashes but not in sync

Step	Check/Test/Action		Action
3.a	Does GPS antenna (located in top of beacon) have an unobstructed view of sky? See Section 2.2	Yes No	Replace Beacon Top Plate Assembly See Section 5.3.1 Correct problem

Table 5-4 – Troubleshooting - Beacon flashes in daytime

Step	Check/Test/Action		Action
4.a	Is photocell (located on top of beacon) obstructed? Check for any foreign matter on top of beacon.	Yes No	Correct problem Replace Beacon Top Plate Assembly See Section 5.3.1

5.3 Beacon Repair Procedures

Warning

Remove power from all wiring and circuitry before servicing the Beacon.

5.3.1 Replacing the Top Plate Assembly (11000003426)

While performing the following steps, check for any loose connections or other damaged components.

Dome Removal

See Figures 5-1 and 5-2. The Dome Assembly (11000001992) is secured to the Beacon base by three latches. One of the latches has a locking screw that must be removed before it can be undone. Undo all three latches located on the base of the Beacon assembly. The Dome assembly lanyard is secured to the Beacon Base support bolt. The Dome may be carefully lifted off the top of the Beacon by gently pulling outward on the lanyard hole tab and letting air enter. Once released, the Dome can be removed and set aside until ready for re-installation.

Top Plate Assembly Removal

See Figure 5-3. Remove the four panhead screws securing the Top Plate Assembly (11000003426) to the LED Module (11000001991). Then unplug the main harness connector from the Controller PCB.

Top Plate Assembly Replacement

Plug the main harness connector into the replacement Top Plate Assembly. Rotate the Top Plate Assembly clockwise to position the harness into the LED Module opening and lower into position. Reinstall using the four retaining screws.

Operation Verification

Apply power to the Beacon and verify that it lights correctly. If not, recheck all connections. If the Beacon functions normally, perform the Dome Reassembly procedure provided below.

Dome Reassembly

Before reinstalling the dome, apply a thin layer of Silicone Lubricant to the O-ring to insure a good seal and prevent water intrusion.

Refit the dome, **CAUTION**. When reinstalling the Dome it is important to hold it level and securely by the lower rim. With even pressure gently lower the dome over the o-ring seal until the bottom lip of the dome is seated on the (3) cast latch pads, ensure that the lanyard tab is approximately centered between two of the latch clamp pads. Clamp all latches and refit the locking screw.

5.3.2 Replacing the Bottom Plate Assembly (11000003427)

Dome Removal

See Figure 5-1 and 5-2. The Dome Assembly (11000001992) is secured to the Beacon base by three latches. One of the latches has a locking screw that must be removed before it can be undone. Undo all three latches located on the base of the Beacon assembly. The Dome assembly lanyard is secured to the Beacon Base support bolt. The Dome may be carefully lifted off the top of the Beacon by gently pulling outward on the lanyard hole tab and letting air enter. Once released, the Dome can be removed and set aside until ready for re-installation.

Top Plate Assembly Removal

See Figure 5-3. Remove the four panhead screws securing the Top Plate Assembly (11000003426) to the LED Module (11000001991). Then unplug the main harness connector from the Controller PCB. Set aside the Top Plate Assembly until ready for re-installation.

LED Module Removal

Undo the (3) knobs holding the LED Module to the Base assembly. The knobs are captive and will remain in the Base Plate. Carefully lift the LED Module enough to allow access to the cable connecting it to the LED Power Supply. Carefully pull the small inline connector between the LED Module and LED Power Supply apart. Pull the large harness through the opening of the LED Module to separate the two assemblies.

Bottom Plate Assembly Removal

See Figure 5-4. To remove the Bottom Plate Assembly (11000003427), first loosen the Ground Stud nut and disconnect the four Ground wires. Unplug the four incoming cable wires from the Terminal Strip TB1. Remove the four screws holding the LED Power Supply to the Base assembly and lift the Bottom Plate Assembly from the Base.

Bottom Plate Assembly Replacement

Position the replacement Bottom Plate Assembly on the Base and secure using the four LED Power Supply screws. Reinstall the four ground wires on the ground stud. Reconnect the four incoming cable wires to the Terminal Strip TB1 using the Wiring Diagram (Figure 4-1) or the Infocard located on the LED Power Supply.

LED Module Reinstall

Route the large harness through the LED Module opening and reconnect the LED Module small inline cable connector. Reinstall the LED Module on the Base using the alignment pins as a guide. Retighten the knobs to secure the LED Module to the Base.

Top Plate Assembly Reinstall

Plug the main harness connector into the Top Plate Assembly. Rotate the Top Plate Assembly clockwise to position the harness into the LED Module opening and lower into position. Reinstall using the four retaining screws.

Operation Verification

Apply power to the Beacon and verify that it lights correctly. If not, recheck all connections. If the Beacon functions normally, perform the Dome Reassembly procedure provided below.

Dome Reassembly

Before reinstalling the dome, apply a thin layer of Silicone Lubricant to the O-ring to insure a good seal and prevent water intrusion.

Refit the dome, CAUTION. When reinstalling the Dome it is important to hold it level and securely by the lower rim. With even pressure gently lower the dome over the o-ring seal until the bottom lip of the dome is seated on the (3) cast latch pads, ensure that the lanyard tab is approximately centered between two of the latch clamp pads. Clamp all latches and refit the locking screw.

5.3.3 Replacing the LED Module (11000001991)

Dome Removal

See Figure 5-1 and 5-2. The Dome Assembly (11000001992) is secured to the Beacon base by three latches. One of the latches has a locking screw that must be removed before it can be undone. Undo all three latches located on the base of the Beacon assembly. The Dome assembly lanyard is secured to the Beacon Base support bolt. The Dome may be carefully lifted off the top of the Beacon by gently pulling outward on the lanyard hole tab and letting air enter. Once released, the Dome can be removed and set aside until ready for re-installation.

Top Plate Assembly Removal

See Figure 5-3. Remove the four panhead screws securing the Top Plate Assembly (11000003426) to the LED Module (11000001991). Then unplug the main harness connector from the Controller PCB. Set aside the Top Plate Assembly until ready for re-installation.

LED Module Removal

Undo the (3) knobs holding the LED Module to the Base assembly. The knobs are captive and will remain in the Base Plate. Carefully lift the LED Module enough to allow access to the cable connecting it to the LED Power Supply. Carefully pull the small inline connector between the LED Module and LED Power Supply apart. Pull the large harness through the opening of the LED Module to separate the two assemblies.

LED Module Replacement

Route the large harness through the replacement LED Module opening and reconnect the LED Module small inline cable connector. Reinstall the LED Module on the Base using the alignment pins as a guide. Retighten the knobs to secure the LED Module to the Base.

Top Plate Assembly Reinstall

Plug the main harness connector into the Top Plate Assembly. Rotate the Top Plate Assembly clockwise to position the harness into the LED Module opening and lower into position. Reinstall using the four retaining screws.

Operation Verification

Apply power to the Beacon and verify it lights correctly. If so, perform the Dome Reassembly procedure provided below.

Dome Reassembly

Before reinstalling the dome, apply a thin layer of Silicone Lubricant to the O-ring to insure a good seal and prevent water intrusion.

Refit the dome, CAUTION. When reinstalling the Dome it is important to hold it level and securely by the lower rim. With even pressure gently lower the dome over the o-ring seal until the bottom lip of the dome is seated on the (3) cast latch pads, ensure that the lanyard tab is approximately centered between two of the latch clamp pads. Clamp all latches and refit the locking screw.

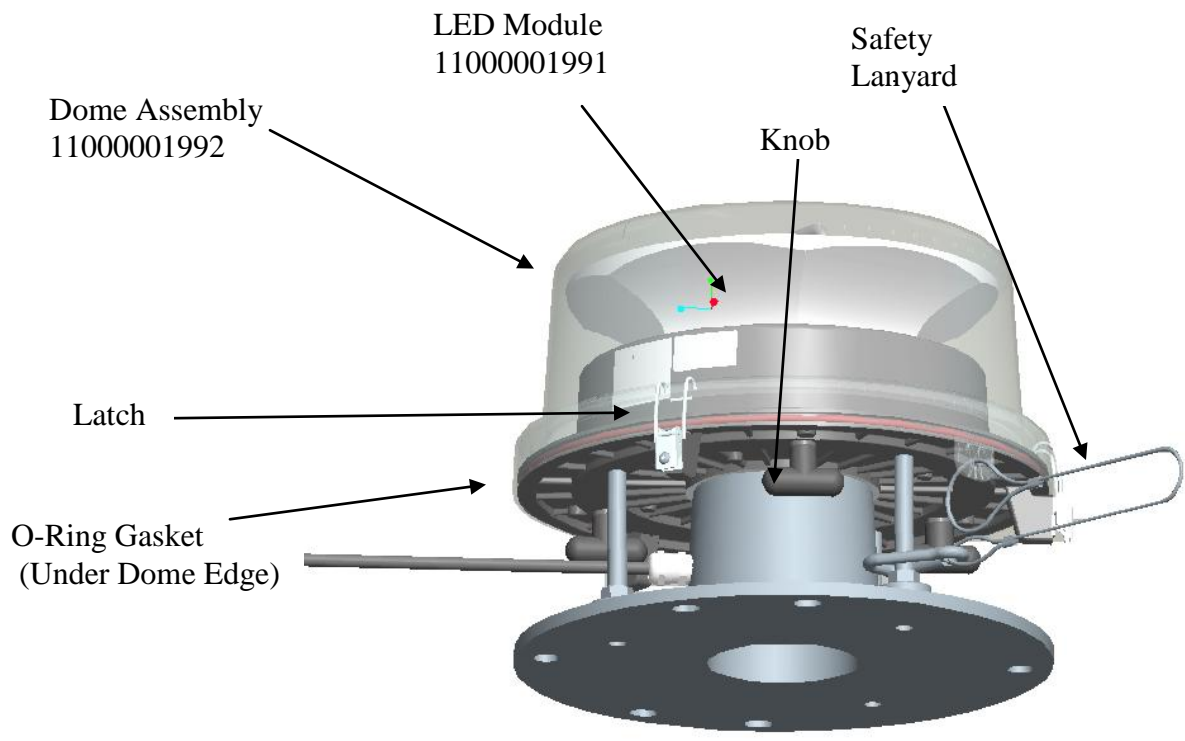

Figure 5-1 – Beacon - External View

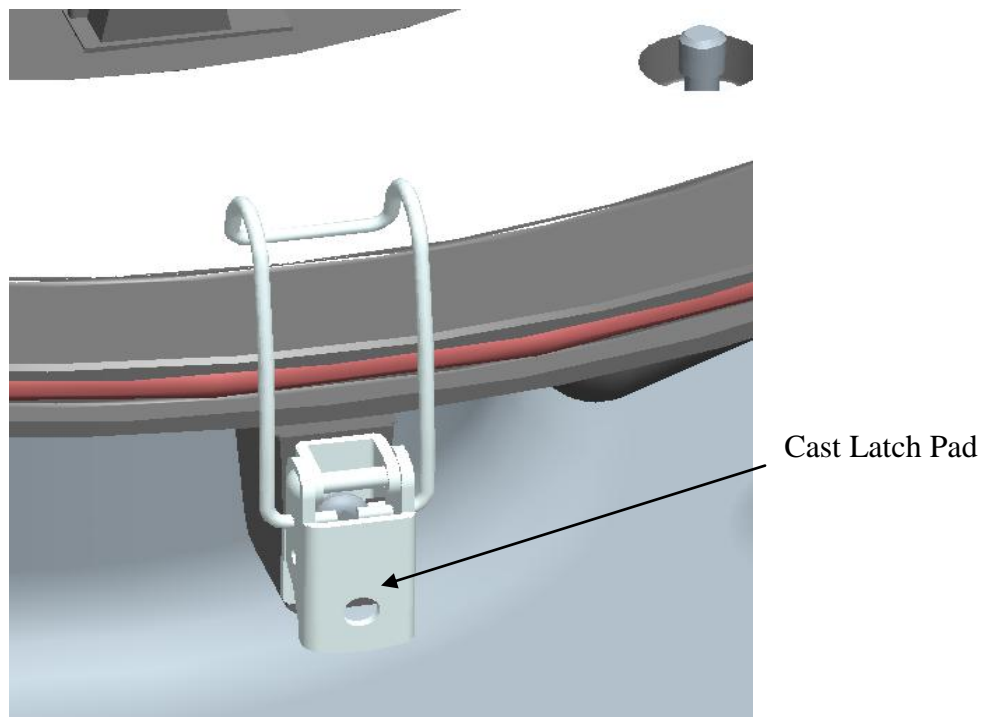

Figure 5-2 – Cast Latch Pad

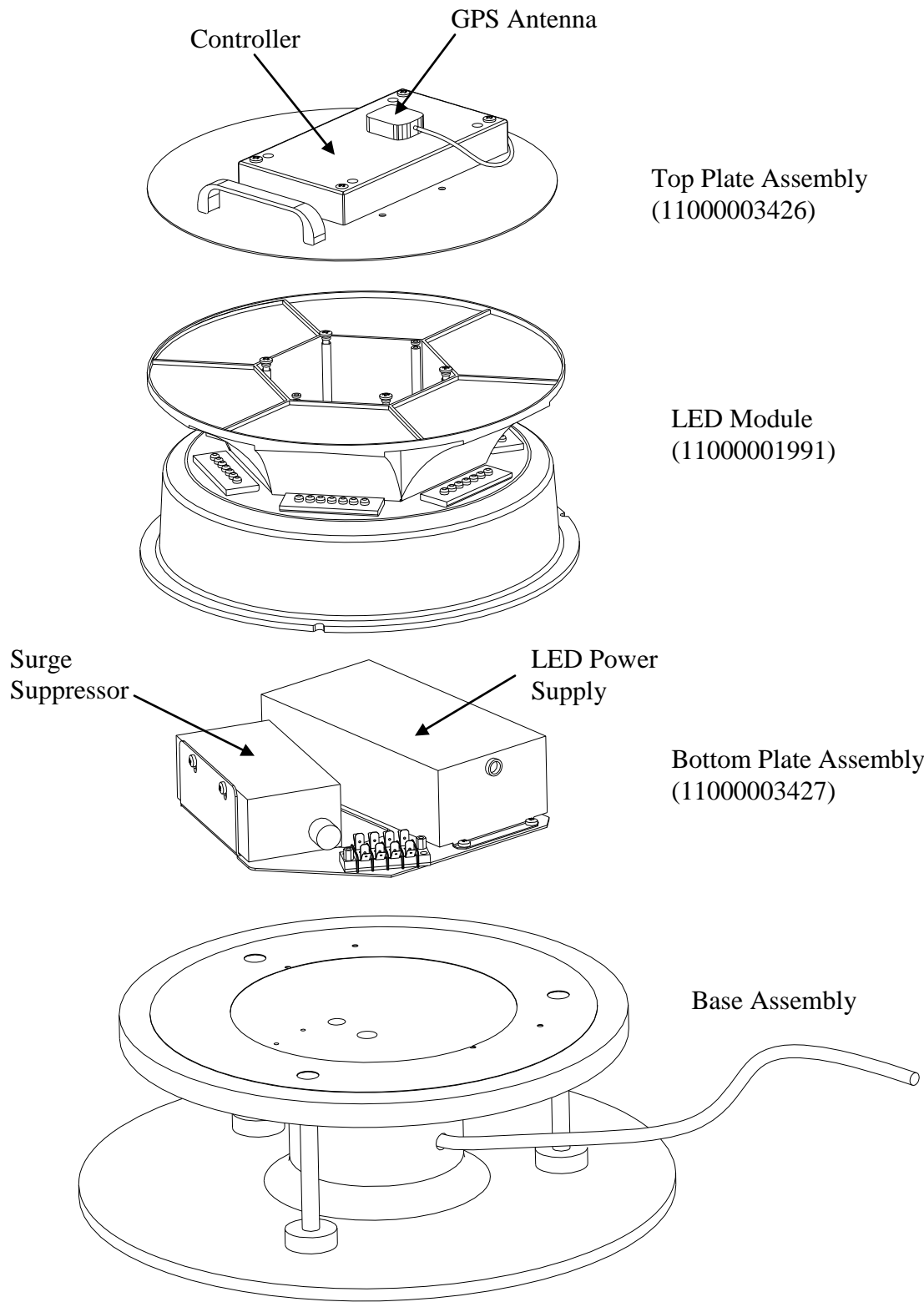

Figure 5-3 – Beacon - Exploded View

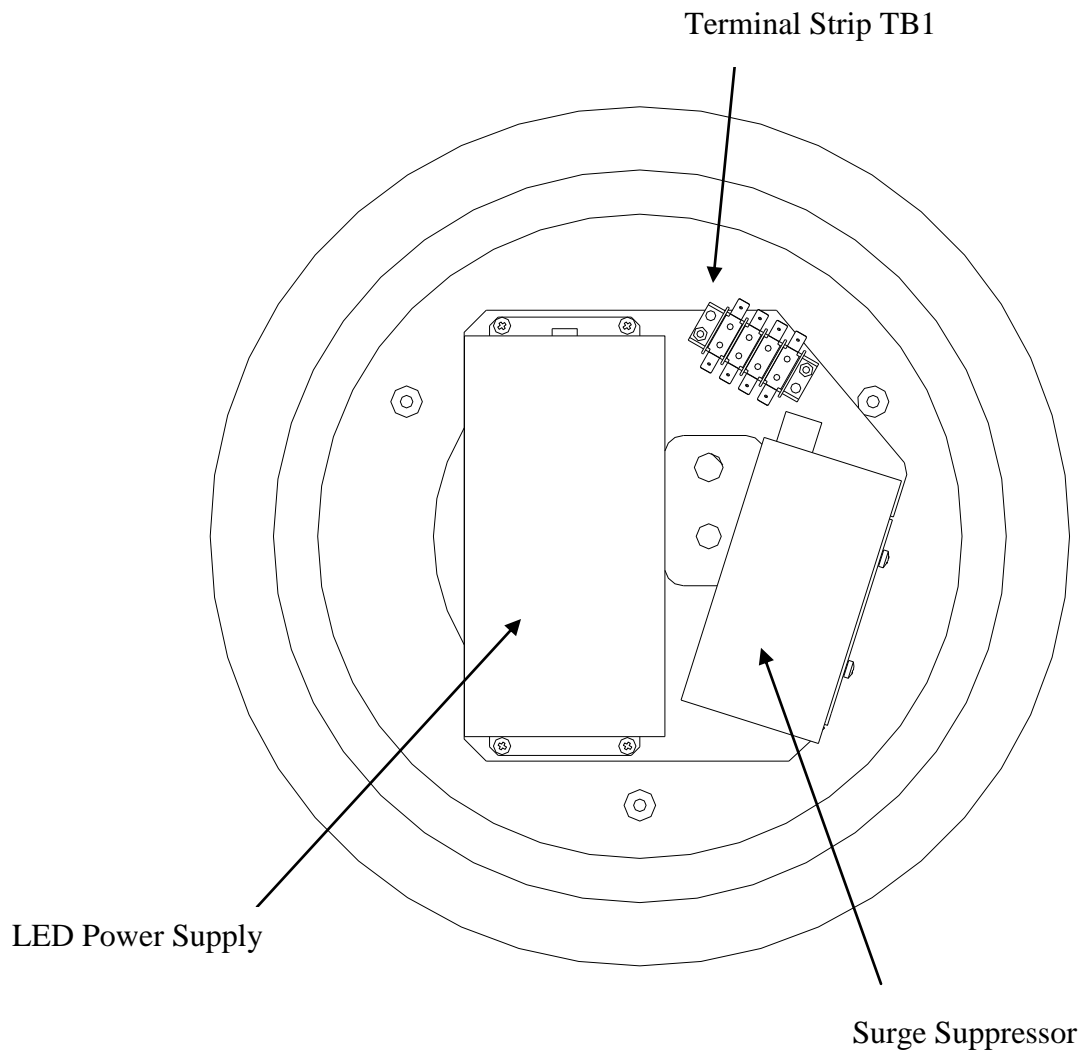

Figure 5-4 – Bottom Plate Assembly (11000003427) - Component Location

5.4 Customer Service

Customer Service: (800) 821-5825

Telephone: (615) 261-2000

Facsimile: (615) 261-2600

Shipping Address:

Flash Technology
332 Nichol Mill Lane
Franklin, TN 37067

5.5 Ordering Parts

To order spare, replacement or optional parts contact Customer Service at 1-800-821-5825.

Table 5-5 – Optional Parts

Description	Part Number
Mounting Bracket Assembly	3991210

Table 5-6 – Spare/Replacement Parts

Description	Part Number
LED Module	11000001991
Dome Assembly	11000001992
Top Plate Assembly	11000003426
Bottom Plate Assembly	11000003427
Silicone O-ring Lubricant	11000004843

Section 6 – Specifications

FAA Type	L-864 Red Obstruction Light
Flashes per Minute	20 FPM
Intensity	2,000 candela (nominal)
Input Voltage Range	120-240VAC
Input Current	0.3 to 0.8A RMS
Frequency	50/60Hz
Wattage	24W (flashing); 48W (steady)
Power Factor	>0.9
Operating Temperature	-40°F to +131°F (-40°C to +55°C)
Weight	
Beacon only	33 lbs (15 kg)
Cable, 50 Feet (15.2 m)	6 lbs (2.7 kg)
Beacon w/ 50 Feet (15.2 m) cable	39 lbs (17.7 kg)
Dimensions	
Height	12.6 in (32 cm)
Width	15.0 in (38.1 cm)
Bolt Hold Down Pattern	Standard Pattern Provided (See Figure 2-1)

Section 7 – Regulatory Compliance and Certifications

- ETL Certified to Federal Aviation Administration (FAA): AC No. (150/5345-43F).
- FAA Engineering Brief No. 67
- Compliant to Canadian Aviation Regulation (CAR): CAR 621.19
- International Civil Aviation Organization (ICAO): Annex 14, 4th Edition, July 2004

Return Material Authorization (RMA) Policy

IF A PRODUCT PURCHASED FROM FLASH TECHNOLOGY MUST BE RETURNED FOR ANY REASON (SUBJECT TO THE WARRANTY POLICY), PLEASE FOLLOW THE PROCEDURE BELOW:

Note: An RMA number must be requested from Flash Technology prior to shipment of any product. No returned product will be processed without an RMA number. This number will be the only reference necessary for returning and getting information on the product's progress.

Failure to follow the below procedure may result in additional charges and delays. Avoid unnecessary screening and evaluation charges by contacting Technical Support prior to returning material.

1. To initiate an RMA, customers should call Flash Technology's Network Operation Center at (800-821-5825) to receive technical assistance and a Service Notification number. The following information is required before a Service Notification number can be generated:

- Site Name/Number / FCC Registration number/ Call Letters or Airport Designator
- Site Owner (provide all that apply – owner, agent or subcontractor)
 - Contractor Name
 - Contractor Company
- Point of Contact Information: Name, Phone Number, Email Address, Fax Number and Cell Phone (or alternate phone number)
- Product's Serial Number
- Product's Model Number or part number
- Service Notification Number (if previously given)
- Reason for call, with a full description of the reported issue

2. The Service Notification number will then serve as a precursor to receiving an RMA number if it is determined that the product or equipment should be returned. To expedite the RMA process please provide:

- Return shipping method
- Purchase Order (if non-warranty repair)
- Shipping Address
- Bill To Address
- Any additional information to assist in resolving the issue or problem

3. A P.O. is required in advance for the replacement of product that may be under warranty. Flash will then, at its discretion issue a credit once the validity of the warranty has been determined.

4. A purchase order (P.O.) is also required in advance for all non-warranty repairs. NOTE: the purchase order is required prior to the issuance of the RMA number.

- If the P.O. number is available at the time of the call, an RMA number will be issued and the customer must then fax or email the P.O. with the RMA number as the reference, to ensure prompt processing.
- If the P.O. number is NOT available at the time of the call, a Service Notification Number will be given to the customer and should be referenced on the P.O. when faxed or emailed to RMA Rep.
- Flash will then, at its discretion repair or replace the defective product and return the product to the customer based on the shipping method selected.
- The customer may purchase a new product before sending in the existing product for repair. If Flash Technology determines the existing product is still covered under warranty a credit will be issued to the customer for the new product.

5. After receiving the Flash Technology RMA number, please adhere to the following packaging guidelines:

- All returned products should be packaged in a way to prevent damage in transit. Adequate packing should be provided taking into account the method of shipment.

Note: Flash Technology will not be responsible for damaged items if product is not returned in appropriate packaging.

6. All packages should clearly display the RMA number on the outside of all RMA shipping containers. RMA products (exact items and quantity) should be returned to:

Flash Technology
Attn: RMA #XXX
332 Nichol Mill Lane
Franklin, TN 37067

7. All RMA numbers:

- Are valid for 30 days. Products received after may result in extra screening and delays.
- Must have all required information provided before an RMA number is assigned.

Return to Stock Policy

- **Parts can be returned within 60 days of ship date and will be subject to a 25% restocking fee. Product must:**
 - Be in the original packaging
 - Not be damaged
- **After 60 days no parts can be returned**