



SERIAL NUMBER

**AN SPX DIVISION**



# **FTC 183-1 System Controller**

---

**Reference Manual  
Part Number F7911831**

Flash Technology, 332 Nichol Mill Lane, Franklin, TN 37067  
(615) 261-2000

## **Front Matter**

### ***Abstract***

This manual contains information and instructions for installing, operating and maintaining the FTC 183-1 System Components.

### ***Copyright***

Copyright © 2011, Flash Technology®, Franklin, TN, 37067, U.S.A.

All rights reserved. Reproduction or use of any portion of this manual is prohibited without express written permission from Flash Technology and/or its licensor.

### ***Trademark Acknowledgements***

Flash Technology® is a registered trademark name.

ElectroFlash™, Flash Tech™, Flash Technology™, FTCA™, Flash™ and the Flash Technology Logo are all trademarks of Flash Technology.

All trademarks and product names mentioned are properties of their respective companies and are recognized and acknowledged as such by Flash Technology.

### ***Disclaimer***

While every effort has been made to ensure that the information in this manual is complete, accurate and up-to-date, Flash Technology assumes no liability for damages resulting from any errors or omissions in this manual, or from the use of the information contained herein. Flash Technology reserves the right to revise this manual without obligation to notify any person or organization of the revision.

In no event will Flash Technology be liable for direct, indirect, special, incidental, or consequential damages arising out of the use of or the inability to use this manual.

### ***Warranty***

Flash Technology warrants all controller components, under normal operating conditions, for 2 years.

# Table of Contents

Front Matter .....	ii
Abstract .....	ii
Copyright .....	ii
Trademark Acknowledgements .....	ii
Disclaimer .....	ii
Warranty .....	ii
List of Figures .....	iv
List of Tables .....	iv
Section 1 – Introduction.....	1
FTC 183-1 System Controller.....	1
Specifications.....	1
Operation.....	1
Front Panel Switches and Indicators (LEDs).....	1
Light Position LED Display.....	2
PCB100 Control Board Switches.....	2
Programming.....	3
Switches .....	3
Jumpers .....	3
Normal Operation .....	3
Manual Operation .....	3
Checkout Procedure .....	4
Chapter 2— Outline, Mounting, and Installation .....	7
Unpacking.....	7
Installation.....	7
Location .....	7
Wiring .....	7
Lightning Protection .....	7
Tools .....	8
Placement.....	8
Mounting.....	8
Installation Checklist .....	8
Chapter 3 — Maintenance and Troubleshooting.....	13
Maintenance.....	13
Troubleshooting.....	13
Failing to Switch State in Remote Mode.....	13
Erratic or Confused Light Operation .....	13
Lights .....	13
LED Displays.....	13
Component Removal and Replacement.....	15
Safety .....	15
Rack Mount Access .....	15
Wall Mount Access.....	15
Control Board Assembly — PCB100.....	15
Display Panel Board Assembly — PCB200.....	15
Transformer — T1 .....	16
Storage .....	16
Chapter 4 — Major Replaceable Parts.....	17

Ordering Parts .....	17
RETURN MATERIAL AUTHORIZATION (RMA) POLICY.....	19

## List of Figures

Figure 1-1 PCB100 Control Board Layout.....	5
Figure 1-2 FTC 183-1 Front Panel Controls.....	6
Figure 1-3 PCB 100 Programming Switches.....	6
Figure 2-1 FTC 183-1R System Controller Mounting and Outline.....	8
Figure 2-2 FTC 183-1W System Controller Mounting and Outline.....	9
Figure 2-3 FTC 183-1 Controller Typical Installation Wiring.....	10
Figure 2-4 FTC 183-1 Panel Connections .....	11
Figure 2-5 FTC 183-1 Controller Internal Wiring.....	12
Figure 4-1 FTC 183-1 System Controller Component Locations .....	18

## List of Tables

Table 1-1 Control Switch.....	2
Table 1-2 Status Lamp Test Switch.....	2
Table 1-3 Front Panel Indicators (LEDs).....	2
Table 1-4 PCB100 Control Board Switches .....	3
Table 1-5 PCB100 Switch and Light Equivalence .....	3
Table 3-1 Major Troubleshooting Symptoms.....	14
Table 3-2 Symptoms Versus Possible Causes .....	14
Table 4-1 Major Replaceable Parts.....	17

## Section 1 – Introduction

### **FTC 183-1 System Controller**

The FTC 183-1 is a System Controller. It synchronizes up to 28 lights, directs flash timing and intensity, and records and reports light operating status. It enables either automatic or manual intensity control, and continuously displays the flashing status of each individual system light. A front panel switch or a remote switch allows you to manually control intensity.

Each light transmits a confirmation signal when it flashes. All lights report to the controller over the same twisted conductor pair. This composite signal is decoded for an array of two-color LED indicators on the front panel. An assigned indicator represents each light in the system. Internal memory retains a transient failure until you reset it manually permitting you to identify a light that only occasionally misses a flash.

The FTC 183-1R fits in a standard 19-inch equipment rack. System wiring connects to a terminal block at the rear of the unit. The FTC 183-1W is in an enclosure allowing the controller to be wall mounted. Opening the front of the enclosure reveals the operating controls. A glass window in the front panel allows you to observe the controller's indicator lights. Otherwise, the FTC 183-1R and 183-1W are electrically the same.

### **Specifications**

Physical: See outline drawings in Section 2 for mounting dimensions.

FTC 183-1R: (H x W x Depth, Wgt)  
7 x 19 x 14.13 in., 10 lbs.  
178 x 483 x 359 mm., 4.5 kg.

FTC 183-1W: (H x W x Depth, Wgt)  
18.8 x 19 x 6 in., 29 lbs.  
478 x 483 x 153 mm., 13 kg.

Electrical:

AC Voltage 120, 208, 240 VAC  $\pm$  10%  
60 Hz  $\pm$  1% single phase  
230 VAC 50 Hz  
Watts 25

Environmental: -50 ° to +55 °C

Alarm Relay: Isolated form C contacts rated at 10 amperes, 240 VAC or 28 VDC resistive load.

### **Operation**

Controls and indicators for normal operation are located on the front panel. Infrequently used programming switches are located internally on the main printed circuit board. The use of these switches, controls, and indicators is described in Table 1-1, Table 1-2, Table 1-3, and Table 1-4, in the following subsections. The controller begins operation as soon as power is applied.

### **Front Panel Switches and Indicators (LEDs)**

The front panel has two switches: the Control Switch and the Status Lamp Test Switch. The Control Switch, a five-position rotary switch, has the following settings: REMOTE, H, M, L, and FLASH INHIBIT. The function of each position is shown in Table 1-1. The Status Lamp Test Switch has the two functions shown in Table 1-2. Table 1-3 describes the function of the LEDs on the front panel.

Table 1-1 Control Switch

Position	Function
Remote	Allows a remote intensity switching device to change the intensity of the lights.
H	Operates the lights at HIGH intensity.
M	Operates the lights at MEDIUM intensity.
L	Operates the lights at LOW intensity.
Flash Inhibit	Flash OFF (lighting units still have power applied)

Table 1-2 Status Lamp Test Switch

Position	Function
Red	Applies a fail signal to all the LED status indicators — for testing the red fail function of the LEDs.
Test (center)*	No test function. Normal position.
Green	Applies a confirm signal to all the LED status indicators — for testing the green confirm function of the LEDs.

*\*The switch is spring-loaded and returns to the center OFF position when released.*

Table 1-3 Front Panel Indicators (LEDs)

LED	Function
High	Glow steadily when the controller is operating the lights in HIGH intensity mode.
Med	Glow steadily when the controller is operating the lights in Medium intensity mode.
Low	Glow steadily when the controller is operating the lights in Low intensity mode.
Manual	Glow steadily when the controller is operating in any mode except REMOTE mode.
Alarm	Indicates the state of the alarm relay. The alarm relay is on if a light fails three times consecutively.

### Light Position LED Display

Two-color LEDs are addressed by signals generated on PCB100. Lights that are confirming a flash set the LEDs to green. Non-confirming lights set the LEDs to red. The Status Lamp Test Switch described in Table 1-2 tests the operation of the LEDs in the indicator array. The RED position sets all the LEDs to red. The GREEN position sets all the LEDs to green.

### PCB100 Control Board Switches

The DISPLAY push-button shows red LEDs for any lights that have missed flashes since the memory was reset. Green glowing LEDs correspond to lights that have not missed flashes. The CLEAR push-button resets the memory (all LEDs are set to green). Table 1-4 summarizes the function of these switches.

Table 1-4 PCB100 Control Board Switches

Position	Function
Display	Displays the LEDs as red that correspond to the light that failed three times.
Clear	Clears remembered failures.

### Programming

Switches on the PCB100 board program the board and configure the controller to the lighting arrangement. Jumper JP9 on PCB100 configures the controller for 50Hz operation.

### Switches

Programming switches are located internally on the PCB100 Control Board. See Figure 1-3. The factory preprograms controllers for your installation. The PCB100 board has twenty-eight programming switches, one for each potential light. The switches are arranged by tier and light number, and these correspond to locations. The format is arranged to operate the lights in the sequence shown in Table 1-5:

Table 1-5 PCB100 Switch and Light Equivalence

Tier & Beacon Switch	Light
Tier 1, Beacon 1	1
Tier 1, Beacon 2	2
Tier 1, Beacon 3	3
Tier 1, Beacon 4	4
Tier 2, Beacon 1	5
Tier 2, Beacon 2	6
Tier 2, Beacon 3	7
and so forth	and so forth

*For every light in the system, the corresponding switch must be closed; all other switches must be left open.*

The controller issues a flash command to the lights every second and receives a

confirmation signal from the lights every second. A failing confirmation signal causes an alarm.

### NOTE

A 50Hz system controller monitors only 23 lights. Use a second synchronized controller and separate monitor line for more lights.

A 60Hz system controller monitors only 28 lights. Use a second synchronized controller and separate monitor line for more lights.

### Jumpers

Figure 1-1 shows jumpers on PCB100. Only JP9 is used with airport lights.

### Normal Operation

The conditions in the following list prevail during normal operation when all lights are flashing:

- All LED indicators in the Light Position display that have programming switches closed are GREEN.
- The ALARM LED is out.
- The Control Switch is in REMOTE, or set to H, M, or L.
- The MANUAL LED is off if the Control Switch is in REMOTE; it is on if the Control Switch is in H, M, or L.
- One of the mode LEDs is glowing according to the intensity of operation; HIGH, MED (MEDIUM), or LOW.
- The I 1 SYNC LED on PCB100 is blinking at a 1-second rate.

### Manual Operation

Select the desired flash intensity by using the Control Switch.

## **Checkout Procedure**

Perform the following steps with the CONTROL and MONITOR wires disconnected at the back of the controller.

### **NOTE**

For step 3 and step 4, some indicators may not operate depending on the configuration of lights. Check the position of programming switches on PCB100.

1. Apply power to the unit and observe that all the LIGHT POSITION LED indicators which have corresponding programming switches closed are RED. The ALARM LED is illuminated.
2. Turn power off.
3. Reconnect the CONTROL and MONITOR wires
4. Put the STATUS LAMP switch to RED and verify that all the LIGHT POSITION LED indicators which have corresponding programming switches closed are RED.
5. Put the STATUS LAMP switch to GREEN and verify that all the LIGHT POSITION LED indicators which have corresponding programming switches closed are GREEN.

6. Step the CONTROL switch through H, M, and L verifying that the appropriate MODE LED becomes lit. The MANUAL LED should be lit when the switch is in any position except REMOTE.

Perform the remaining steps with the CONTROL and MONITOR wires attached for normal operation and verify that the programming switches (see Subsection Programming) are set correctly.

7. All LED indicators that have program switches closed should be green and the ALARM LED should be out. Refer to Section 3 — Maintenance and Troubleshooting if this condition is not achieved.
8. If it is possible to observe the lights, rotate the CONTROL switch through H, M, L, and FLASH INHIBIT, verifying the response of the lights at each step. Verify that none of the lights flash when the controller is set to the FLASH INHIBIT position.

### **CAUTION**

The units remain powered in the FLASH INHIBIT position, even though the lights do not flash.



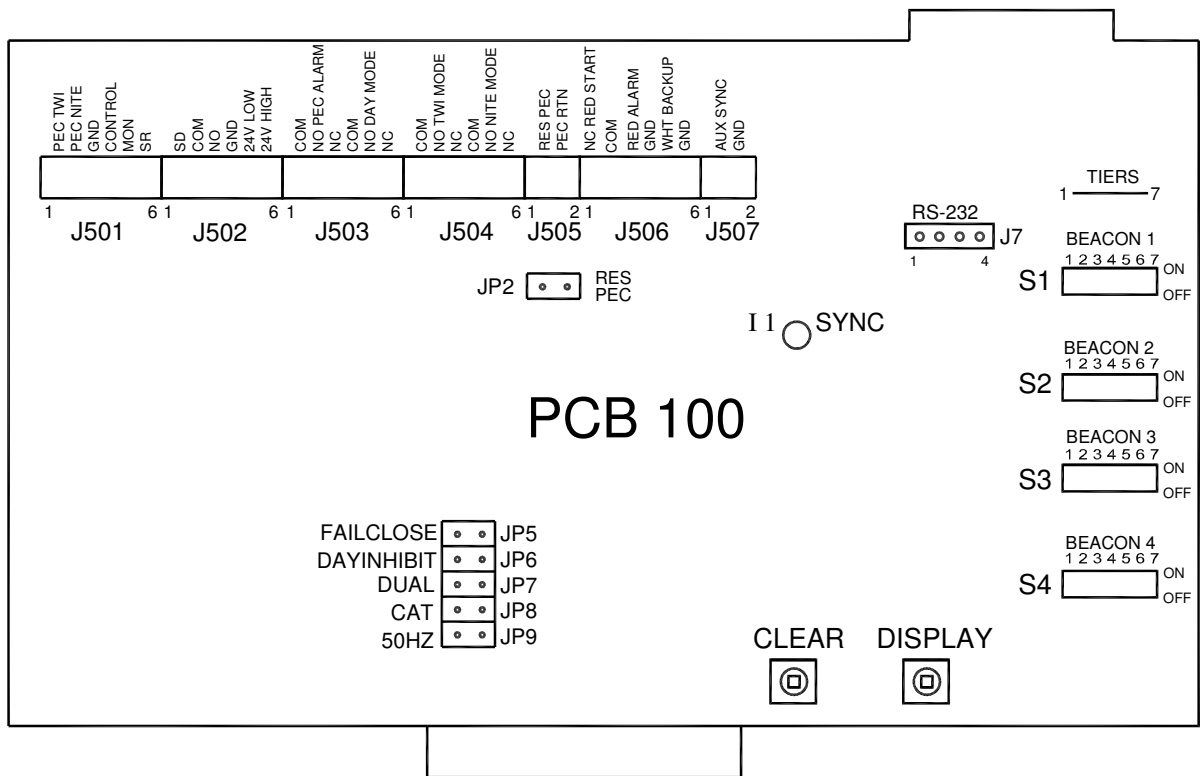

Figure 1-1 PCB100 Control Board Layout

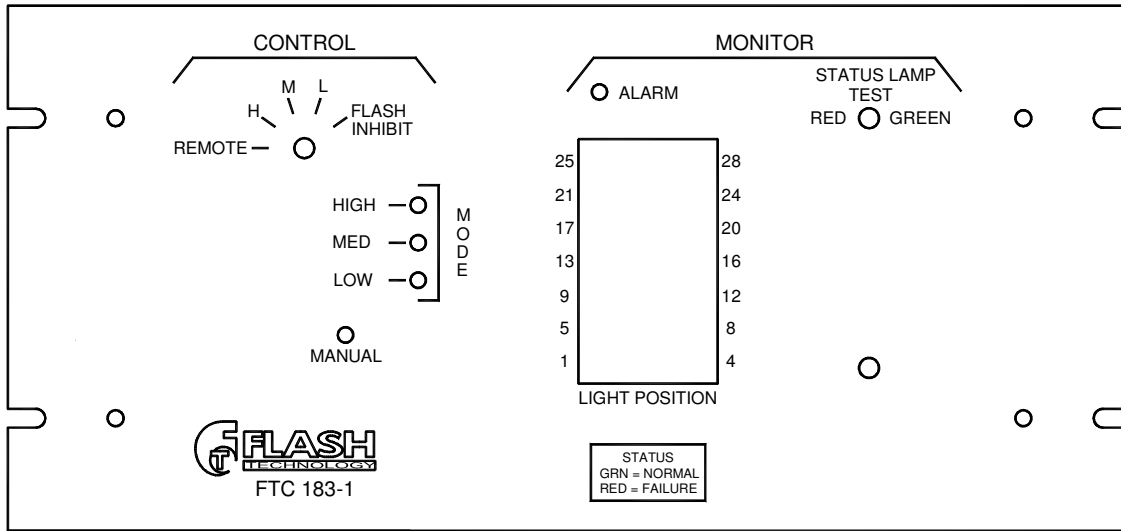

Figure 1-2 FTC 183-1 Front Panel Controls

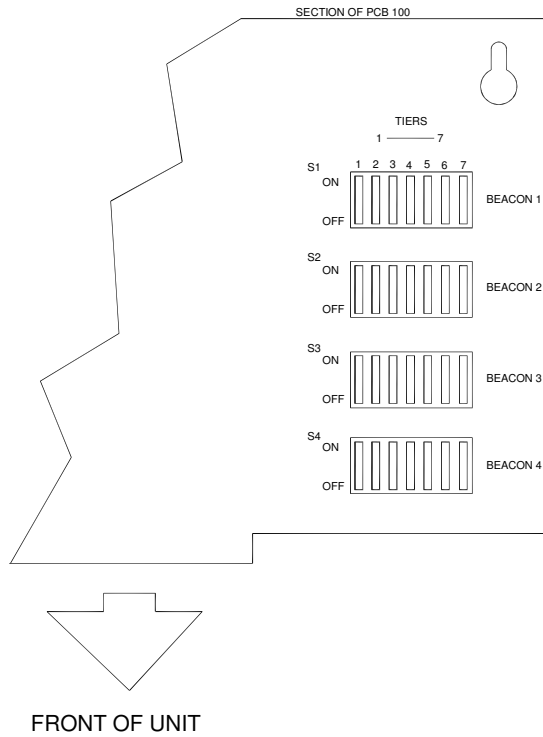

Figure 1-3 PCB 100 Programming Switches

## Chapter 2— Outline, Mounting, and Installation

### NOTE

Only general information for a typical installation is presented here. Thus, more specific information may be needed for your site.

Consult any installation drawings prepared especially for your site or supplied with the equipment.

If installation drawings prepared specifically for your site disagree with information provided in this manual, the installation drawings should take precedence.

### **Unpacking**

Inspect shipping cartons for signs of damage before opening. Check package contents against the packing list and inspect each item for visible damage. Promptly report damage claims to the freight handler.

Maintain the package identity (for example: Light 1, Light 2, and so forth) of each light in your system when it arrives. Install the system as called out on drawings because it has been factory programmed for operation at a specific location.

### **Installation**

Details about unit placement, conduit layout, and system wiring should appear on *system installation drawings* prepared by others. You will receive only a *typical installation drawing* from Flash Technology showing the installation wiring of a system similar to yours (same number of lights, accessories, and so forth).

### **Location**

Locate the FTC 183-1 in an area with restricted access. Controllers are available in outdoor enclosures that can be attached to any vertical surface.

You can place the FTC 183-1 anywhere within 2500 feet of the most distant light without further consideration. Consult with the factory if a greater distance is necessary.

### **Wiring**

Wire your system according to the wiring diagram provided with the equipment. The diagram may have been prepared by Flash Technology or others.

System wiring consists of primary power and signal distribution wiring. Primary power is usually taken from a load center to the various items of equipment. Signal wiring is between the lights and the FTC 183-1.

Three-phase power may be used for the system. The lights are connected line-to-line and use phases AB, BC, and AC. Connect the controller to phase AC. Failure to ensure optimum phasing as described could result in intensity control problems.

Figure 2-3 shows the system controller wiring in a typical installation. Your installation may differ; consult the installation drawings for your site.

### NOTE

The System Controller does not control power to the lights.

Make electrical connections at the terminal block.

### **Lightning Protection**

All Flash Technology equipment is designed to withstand severe transient over-voltages. However, a lightning arresting system must be installed to prevent eventual damage by lightning. Transient suppressors from line-to-line and line-to neutral are recommended at the primary power load center.

## Tools

No special tools are necessary.

## Placement

Considerations are access to the unit, proximity to a very strong RF field, and exposure to direct lightning strikes. Direct exposure to strong radio frequency (RF) radiation could damage some of the components or interfere with proper performance. Flash Technology recommends placing the unit at an adequate distance from a powerful RF radiator. Also, a location where you can conveniently view front panel indicators related to light operation is recommended.

## Mounting

Mounting dimensions for the FTC 183-1R are shown in Figure 2-1. Outline, mounting, and clearance dimensions for the FTC 183-1W are shown in Figure 2-2. Four 10-24 x 1/2-inch screws are required.

## Installation Checklist

Use the following checklist when installing the equipment:

- Inspect each unit for damage that might have occurred during installation.
- Consult any installation drawings for placement, mounting, wiring details, and power phasing.
- Verify that primary power voltage is the value stated on the ID plate.
- Provide a power disconnect switch or a circuit breaker.
- Verify that phasing is correct between each light and the System Controller.
- Check the control/monitor cable connections at the lights and the System Controller. The shield must be tied to chassis.
- Check the lightning protection system.
- Be sure that junction boxes will drain properly.

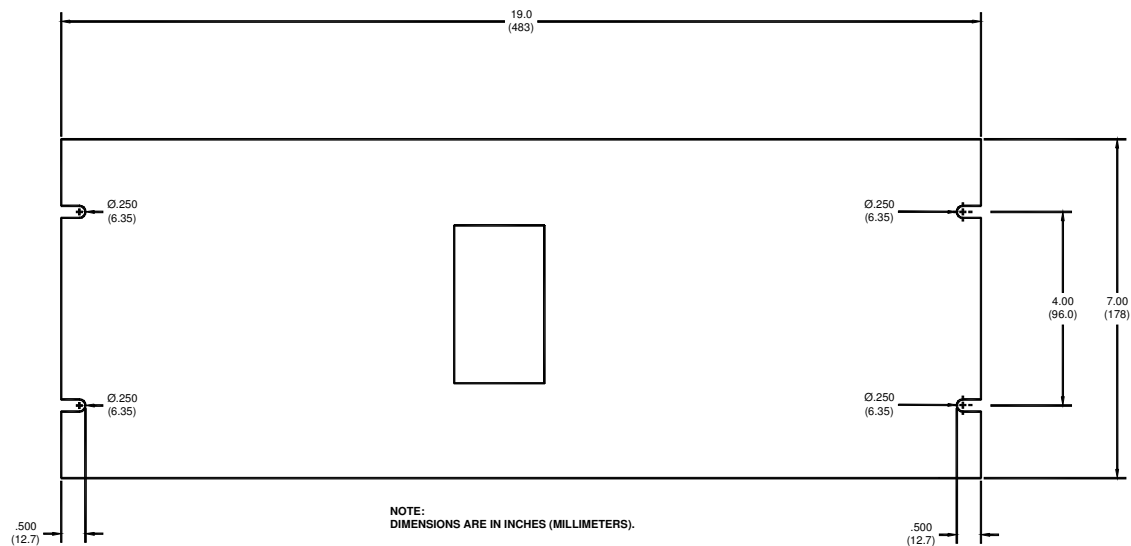

Figure 2-1 FTC 183-1R System Controller Mounting and Outline

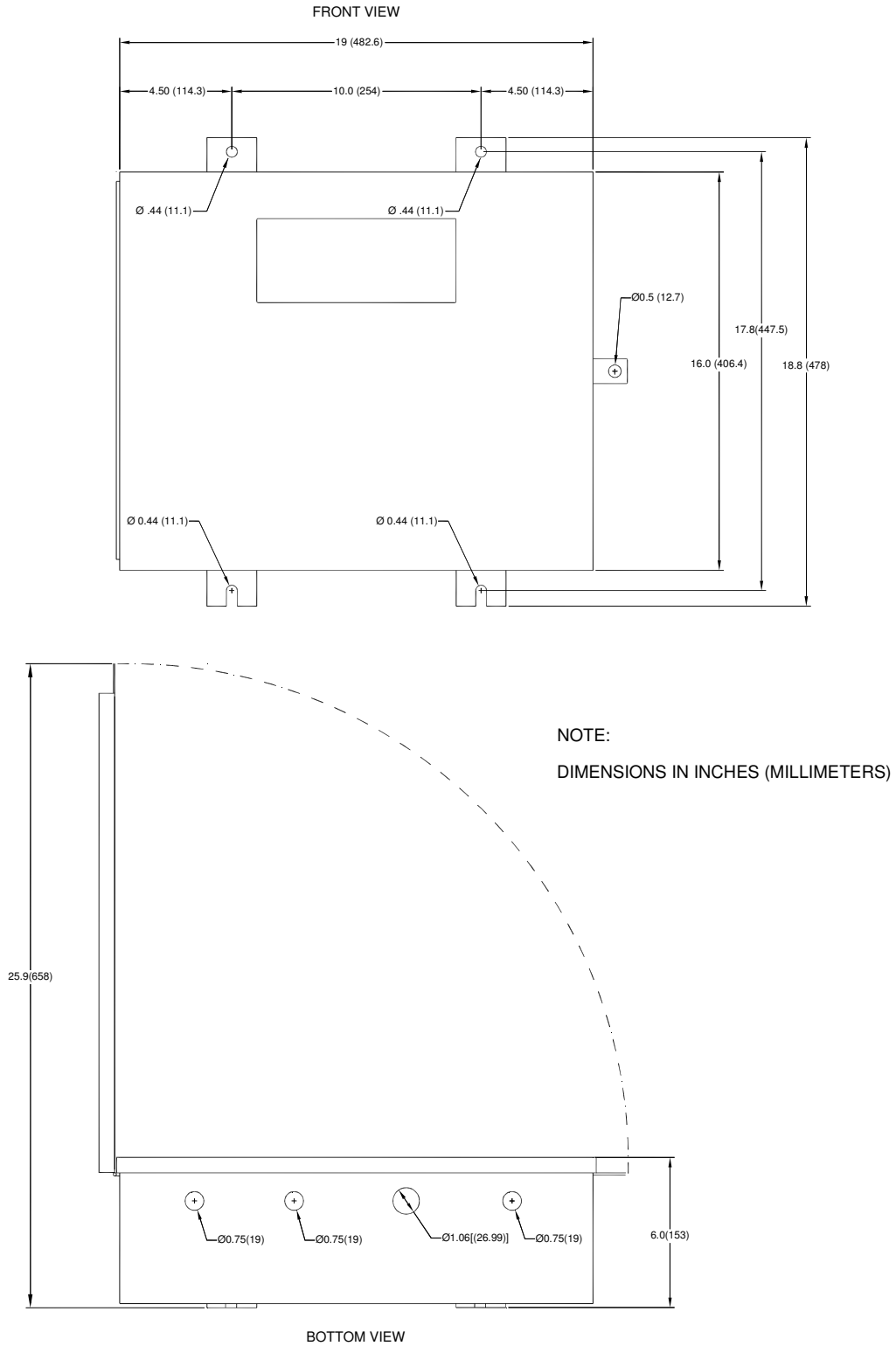

Figure 2-2 FTC 183-1W System Controller Mounting and Outline

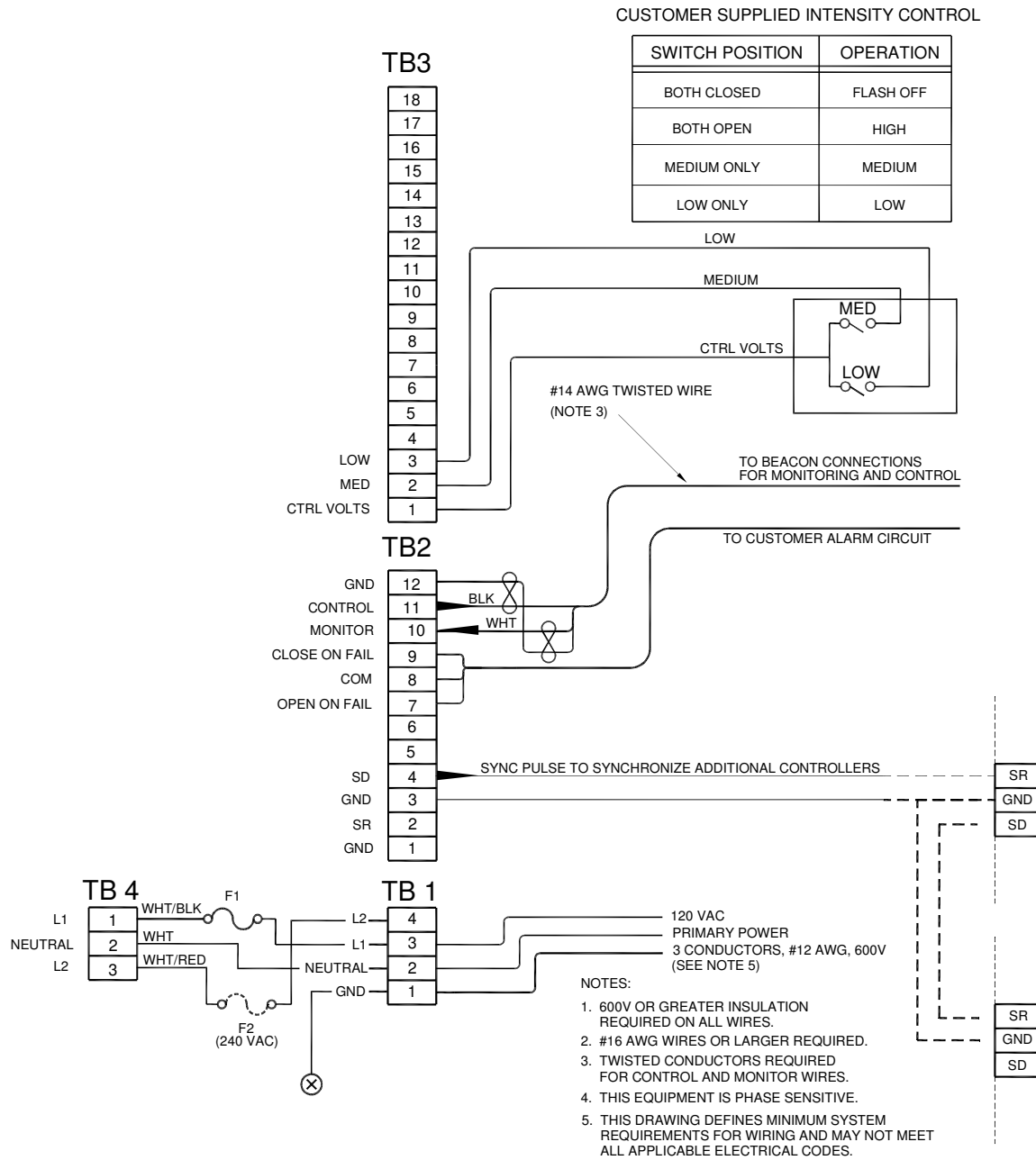

Figure 2-3 FTC 183-1 Controller Typical Installation Wiring

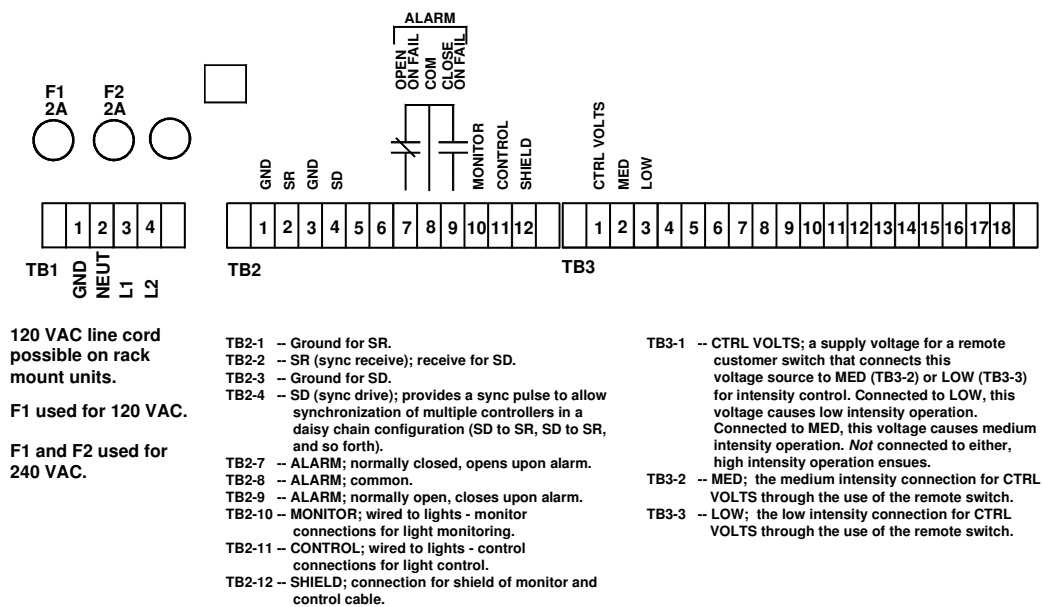

Figure 2-4 FTC 183-1 Panel Connections

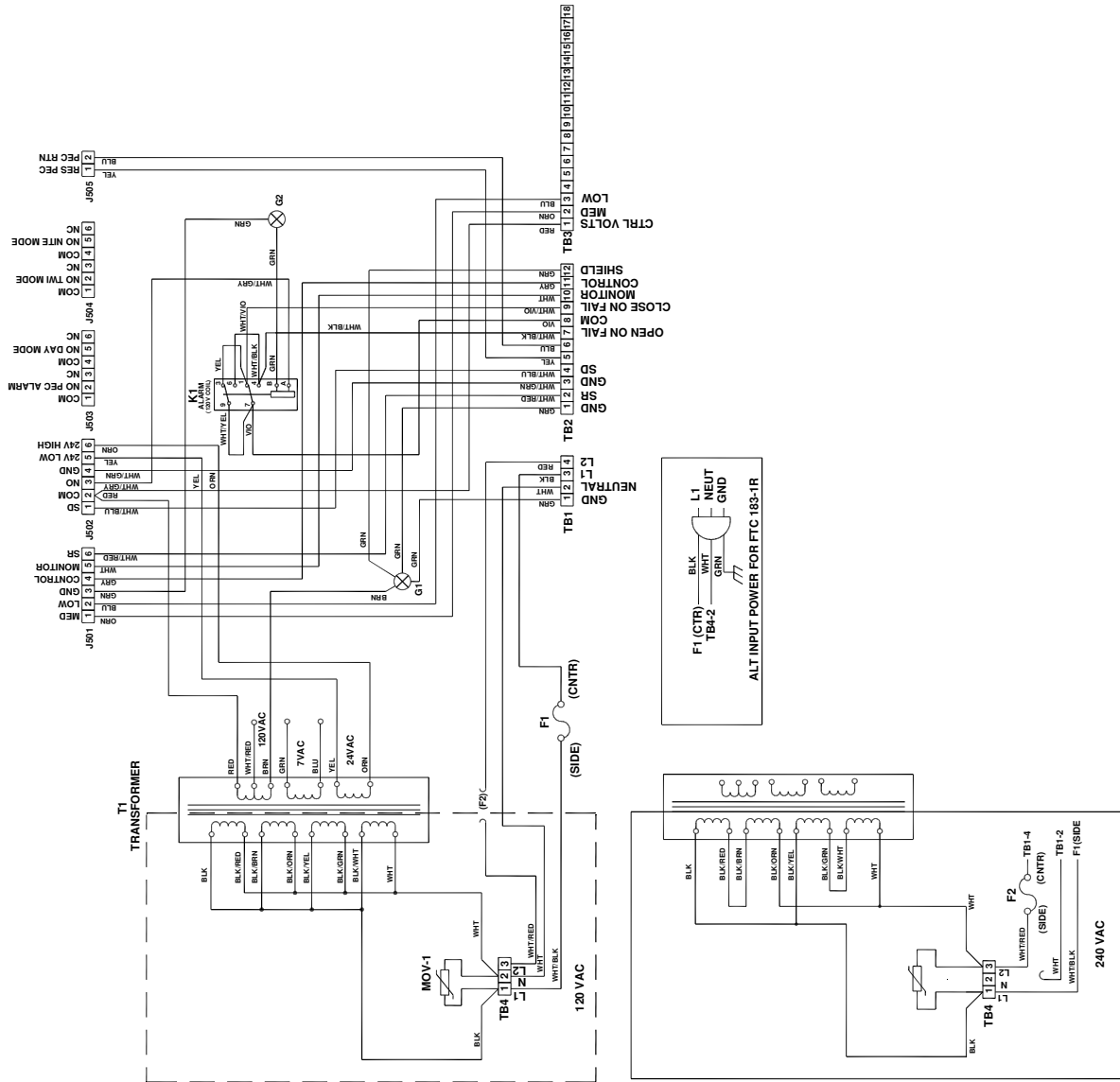

Figure 2-5 FTC 183-1 Controller Internal Wiring



## Chapter 3 — Maintenance and Troubleshooting

### **Maintenance**

No scheduled maintenance is required for this equipment although the circuit boards should be kept free of accumulated dust. Brush and vacuum as necessary.

#### **NOTE**

Do not use compressed air for cleaning this equipment.

Clean the fingers of the printed circuit board connectors when necessary — use only a contact cleaner recommended for electronic circuit components. Do not polish with any kind of abrasive material.

### **Troubleshooting**

The most effective troubleshooting procedure begins with observing the behavior of the system. This often leads directly to a faulty component or other abnormal condition. Many symptoms of abnormal operation observed at the controller may originate at some other part of the system.

Table 3-1 and Table 3-2 contain information to help locate the cause of a problem. Table 3-1 is a list of symptoms, which might be observed if a malfunction occurs. In Table 3-2, these symptoms are related to possible causes.

### **Failing to Switch State in Remote Mode**

Using the Control switch, select each of the manual modes and verify that the lights follow the intensity indicated by the switch position. If they do, the trouble is likely the remote control switch operated in REMOTE Mode. Note that some lights may be difficult to see in bright daylight.

### **Erratic or Confused Light Operation**

Nearby radio transmitters or radar may cause radio frequency interference on control and monitor lines or within the lights or controller. Also, check power line phasing on 3-phase power systems. The controller and lights should be on the same phase.

Try swapping the PCB100 Control Board with a board known to be in good condition. *Ensure that the switches on both boards are set the same before you swap them.*

### **Lights**

If all lights are not flashing, check the COMM. cable to that light. Lights require a command to flash. Check that the switches on the PCB100 board conform to the setup of the system lights.

### **LED Displays**

Look at and analyze the LED displays on the front panel. LEDs indicate manual operating modes when you use the CONTROL switch. Red LEDs in the LIGHT POSITION window indicate failed lights.

The DISPLAY switch on PCB100 shows previously failed lights in the LIGHT POSITION window. The CLEAR switch on PCB100 resets these stored failures.

*See Table 1-3. See also subsection Front Panel Switches and Indicators (LEDs) on Page 1 and subsection Light Position LED Display on page 2.*

Table 3-1 Major Troubleshooting Symptoms

Code	Observed Symptom
A	Controller inoperative; no LEDs are lit
B	Failure in AUTO mode (remote intensity control). Stays in same mode or always high intensity.
C	One LED Indicator RED
D	One LED indicator RED, but cycles BLK to RED repetitively
E	Lights OK, but all LEDs are RED
F	All LEDs cycle BLK to RED repetitively
G	Lights bright in LOW mode, weak in HIGH mode
H	LEDs do not respond at all
I	No lights flash

Table 3-2 Symptoms Versus Possible Causes

Component or Condition	Symptoms from Table 3-1								
	A	B	C	D	E	F	G	H	I
Line fuse F1, line power, or transformer T1.	X								
Remote intensity control switch or Mode Selector Switch on FTC 183-1; wiring for remote control switch		X							
Light not flashing*			X						
Light flashing out of sync*				X					
Control signal line open									X
Control signal line shorted									X
Monitor signal line open						X			
Monitor signal line shorted						X			
PCB 100		X	X	X	X	X	X	X	
PCB 200								X	
Incorrect Power line phase							X		

\*Consult troubleshooting section in the FTS 400/800A Reference Manual.

## **Component Removal and Replacement**

The following procedures explain how to remove and re-install selected components that may require procedures that are not self-evident. Refer to Figure 4-1.

### **Safety**

For all service that requires removal or replacement, *turn off the power or remove the fuses.*

### **Rack Mount Access**

1. Slide the unit out of the rack.
2. Remove the two top access covers on the chassis for access to the inside components.

### **Wall Mount Access**

1. Swing open the cabinet cover.
2. Remove the large top panel that supports the PCB200 display panel board for access to the inside components.

### **Control Board Assembly — PCB100**

#### *Removal*

1. Use either of the previous subsections Rack Mount Access or Wall Mount Access as required.
2. Disconnect the green connectors from PCB100. Use a side-to-side motion to ease their removal.
3. Loosen, but do not remove, the two slotted screws holding down the circuit board.
4. Disengage this circuit board from the display panel board cable connector and lift it away when the screw heads clear the keyhole slots.

#### *Replacement*

1. Reverse the removal procedure. Ensure that PCB100 is fully engaged with display panel board cable connector.

### **Display Panel Board Assembly — PCB200**

#### *Removal*

1. Use either of the previous subsections Rack Mount Access or Wall Mount Access as required.
2. Unplug the display panel board cable.
3. From the front, remove the hex nuts from the switches. Use a nut driver. Take care to prevent scratching the paint while removing the nuts.
4. Behind the front panel, remove the four screws holding the display panel board to the front panel.

#### *Replacement*

1. Reverse the removal procedure.

### **Fail Relay — K1**

#### *Removal*

1. Use either of the previous subsections Rack Mount Access or Wall Mount Access as required.
2. On the main chassis, disconnect the harness at the relay. These harness wires unplug individually.
3. For the rack-mounted unit, remove the Phillips-head screw holding the relay to the main chassis.
4. For the wall-mounted unit, remove the four nuts that hold the chassis to the base of the cabinet. Support the chassis and remove the screw on the side of the chassis that holds the relay.

#### *Replacement*

1. Reverse the removal procedure.

## **Transformer — T1**

### *Removal*

1. Use either of the previous subsections Rack Mount Access or Wall Mount Access as required.
2. Remove the transformer wires from the terminals of green plug J502 on the PCB100 board.
3. Remove the 5/16-inch hex nuts from the two mounting screws.

### *Replacement*

1. Reverse the removal procedure. Refer to the internal wiring in Figure 2-5. Follow the color code exactly.

### **Storage**

No special considerations are required for long-term storage of the controller. Circuit boards, when not installed in the equipment, should be kept in antistatic bags or containers.

# Chapter 4 — Major Replaceable Parts

## Ordering Parts

To order spare or replacement parts, contact Flash Technology customer service at 1-800-821-5825.

## Major Replaceable Parts

Table 4-1 lists the major replaceable parts for the system controller. Refer to Figure 4-1 for component locations.

## Returning Equipment

To return equipment to Flash Technology, contact Customer Service at 1-800-821-5825 for a Return Material Authorization (RMA) number.

## Repackaging

Return the equipment in a container that provides maximum protection during shipping and handling. If the original cartons and packaging material are no

longer available, package the FTC 183-1 Controller in a strong double corrugated carton.

Pad the FTC 183-1 so that corners cannot penetrate the box during shipment. Box the FTC 183-1 using a double thickness cardboard container and adequate padding. Do not drop. Use appropriate warning labels on the outside of the container.

## Customer Service

Customer Service      1-800-821-5825  
Flash Technology      (615) 261-2000  
Facsimile                (615) 261-2600

### Shipping Address:

Flash Technology  
332 Nichol Mill Lane  
Franklin, TN 37067

Table 4-1 Major Replaceable Parts

Item	Description	Part Number
F1	Fuse, Input Power, MDL 2A	4900342*
K1	Relay, Alarm	4900501
PCB 100	Control Board	2471912
PCB 200	Panel Board	2472001
T1	Transformer 120 V Transformer 240 V	8590701 8611201
TB1	Terminal Strip, 4 Position	4902073
TB2	Terminal Strip, 12 Position	4902074
TB3	Terminal Strip, 18 Position	4901930
TB4	Terminal Strip, 3 Position	4902155
VR1	Varistor, 120 VAC	6901079*

\*Recommended as a spare part.

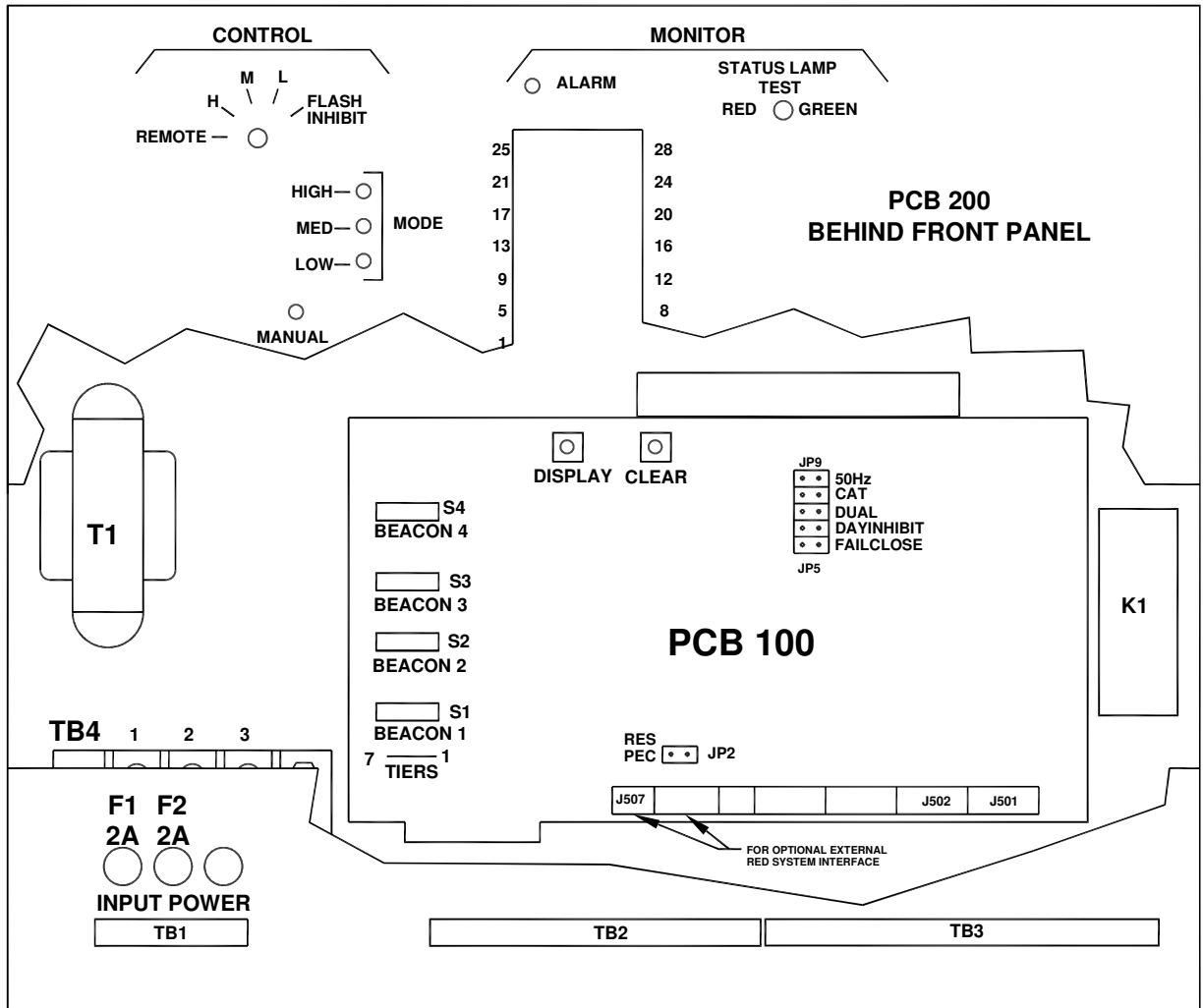

Figure 4-1 FTC 183-1 System Controller Component Locations

# RETURN MATERIAL AUTHORIZATION (RMA) POLICY

IF A PRODUCT PURCHASED FROM FLASH TECHNOLOGY MUST BE RETURNED FOR ANY REASON (SUBJECT TO THE WARRANTY POLICY), PLEASE FOLLOW THE PROCEDURE BELOW:

Note: An RMA number must be requested from Flash Technology prior to shipment of any product. No returned product will be processed without an RMA number. This number will be the only reference necessary for returning and getting information on the product's progress.

**Failure to follow the below procedure may result in additional charges and delays. Avoid unnecessary screening and evaluation charges by contacting Technical Support prior to returning material.**

**1. To initiate an RMA, customers should call Flash Technology's National Operations Center (NOC) at (800-821-5825) to receive technical assistance and a Service Notification number. The following information is required before a Service Notification number can be generated:**

- Site Name/Number / FCC Registration number/ Call Letters or Airport Designator
- Site Owner (provide all that apply – owner, agent or subcontractor)
  - Contractor Name
  - Contractor Company
- Point of Contact Information: Name, Phone Number, Email Address, Fax Number and Cell Phone (or alternate phone number)
- Product's Serial Number
- Product's Model Number or part number
- Service Notification number (if previously given)
- Reason for call, with a full description of the reported issue

**2. The Service Notification number will then serve as a precursor to receiving an RMA number if it is determined that the product or equipment should be returned. To expedite the RMA process, please provide:**

- Return shipping method
- Purchase Order (if non-warranty repair)
- Shipping Address
- Bill To Address
- Any additional information to assist in resolving the issue or problem

**3. A purchase order (P.O.) is required in advance for the replacement of product that may be under warranty. Flash will then, at its discretion issue a credit once the validity of the warranty has been determined.**

**4. A P.O. is also required in advance for all non-warranty repairs. NOTE: the P.O. is required prior to the issuance of the RMA number.**

- If the P.O. number is available at the time of the call, an RMA number will be issued and the customer must then fax or email the P.O. with the RMA number as the reference, to ensure prompt processing.
- If the P.O. number is NOT available at the time of the call, a Service Notification Number will be given to the customer and should be referenced on the P.O. when faxed or emailed to RMA Rep.
- Flash Technology will then, at its discretion, repair or replace the defective product and return the product to the customer based on the shipping method selected.
- The customer may purchase a new product before sending in the existing product for repair. If Flash Technology determines the existing product is still covered under warranty a credit will be issued to the customer for the new product.

**5. After receiving the Flash Technology RMA number, please adhere to the following packaging guidelines:**

- All returned products should be packaged in a way to prevent damage in transit. Adequate packing should be provided taking into account the method of shipment.

**Note: Flash Technology will not be responsible for damaged items if product is not returned in appropriate packaging.**

**6. All packages should clearly display the RMA number on the outside of all RMA shipping containers. RMA products (exact items and quantity) should be returned to:**

Flash Technology  
Attn: RMA #XXX  
332 Nichol Mill Lane  
Franklin, TN 37067

**7. All RMA numbers:**

- Are valid for 30 days. Products received after may result in extra screening and delays.
- Must have all required information provided before an RMA number is assigned.

**RETURN TO STOCK POLICY**

- **Parts can be returned within 60 days of ship date and will be subject to a 25% restocking fee. Product must:**
  - Be in the original packaging
  - Not be damaged
- **After 60 days no parts can be returned.**