

# ➤ Flash Technology



## **FTW 175** **Wireless Monitoring System**

---

**Reference Manual**  
**Part Number 7911751**

SERIAL NUMBER

Flash Technology, 332 Nichol Mill Lane, Franklin, TN 37067  
[www.spx.com/en/flash-technology](http://www.spx.com/en/flash-technology)  
(615) 261-2000



## **Front Matter**

### ***Abstract***

This manual contains information and instructions for installing, operating and maintaining the FTW 175 Wireless Monitoring System.

### ***Copyright***

Copyright © 2015, Flash Technology, Franklin, TN, 37067, U.S.A.

All rights reserved. Reproduction or use of any portion of this manual is prohibited without express written permission from Flash Technology and/or its licensor.

### ***Trademark Acknowledgements***

Flash Technology and Vanguard are registered trademarks of SPX Corporation.

All other trademarks and product names mentioned are properties of their respective companies, and are recognized and acknowledged as such by Flash Technology.

### ***Disclaimer***

While every effort has been made to ensure that the information in this manual is complete, accurate and up-to-date, Flash Technology assumes no liability for damages resulting from any errors or omissions in this manual, or from the use of the information contained herein. Flash Technology reserves the right to revise this manual without obligation to notify any person or organization of the revision.

In no event will Flash Technology be liable for direct, indirect, special, incidental, or consequential damages arising out of the use of or the inability to use this manual.

### ***Warranty***

With proper installation and with normal operating conditions, Flash Technology warrants all components, for 1 year.

# Table of Contents

Front Matter .....	i
Table of Contents .....	ii
List of Figures .....	iii
List of Tables .....	iii
Section 1 – Introduction .....	1
Introduction .....	1
Description .....	1
Specifications .....	1
Section 2 – Initial On-Site Wireless Service Check .....	3
Unpacking .....	3
Verify Wireless Service .....	3
Finding the Best Install Location .....	3
Section 3 – Mounting and Installation .....	4
Mounting .....	4
Installation .....	4
AC Power Wiring .....	4
Dry Contact Input Wiring .....	4
RS-485 Wiring .....	4
Antenna Mounting Bracket .....	4
Grounding .....	5
Status Indicator LED's .....	6
Section 4 – Activation .....	13
Monitoring .....	13
Section 5 – Recommended Spare & Replaceable Parts .....	14
Customer Service .....	14
Ordering Parts .....	14
Return Material Authorization (RMA) Policy .....	15

## List of Figures

Figure 1-1 – FTW 175 Internal Wiring & Component Layout .....	2
Figure 2-1 – Wireless Service Label.....	3
Figure 3-1 – AC Termination .....	5
Figure 3-2 – Dry Contact Input Label.....	5
Figure 3-3 – PCB 9039 Layout and External Wiring .....	7
Figure 3-4 – Enclosure Mounting Footprint .....	8
Figure 3-5 – RS-485 Installation with FTB Strobe System.....	9
Figure 3-6 – RS-485 Installation with FLC 36XX .....	10
Figure 3-7 – Antenna Types .....	11
Figure 3-8 – Antenna Universal Mounting Bracket .....	12
Figure 4-1 – Wireless Number.....	13

## List of Tables

Table 3-1 – PCB 9039 LED's.....	6
Table 5-1 – Major Replaceable Parts.....	14
Table 5-2 – Optional Items .....	14



## Section 1 – Introduction

### **Introduction**

The FTW 175 Wireless Monitoring System is available configured for service provided by AT&T or Verizon 3G (or 2G) wireless networks. Monitoring of site equipment is provided through RS-485 communications and/or four (4) dry contact inputs. The unit also monitors site power.

Equipment monitoring through RS-485 communications is available with all Flash Technology FLC series controllers and any FTB strobe system equipped with a 9038 or 4747 (Ver. 6.9 or higher) PCB.

Dry contacts are typically alarm relays provided by equipment for external monitoring of alarm conditions. Each input of the FTW 175 can be configured by Flash Technology's National Operations Center (NOC) to alarm on either open or closed status. **Alarm on open is preferred for fail safe monitoring.**

All alarm and communication monitoring is handled by the NOC.

**Important:** Before permanently installing and/or wiring the wireless monitoring unit, power-up the system on-site to ensure wireless service in your area. Refer to Section 2 for detailed instructions.

When removing power from the equipment, ensure that the red wire to the battery is disconnected first. Reconnect battery after work is completed.

### **Description**

The component layout and internal wiring of the unit is shown in Figure 1-1. The dry contact inputs are located on J2 of PCB 9039 as shown in Figure 3-3.

### **Specifications**

#### Physical

13.33H x 11.30W x 7.11D inches  
(External)

11 lbs.

#### Electrical

AC Voltage 120 VAC, 60 Hz

Power 7VA

Battery Operation 4+ hrs





## Section 2 – Initial On-Site Wireless Service Check

### Unpacking

Inspect shipping cartons for signs of damage before opening them. Check package contents against the packing list and inspect each item for visible damage. Report damage claims promptly to the freight handler.

### Verify Wireless Service

**Important:** The following steps will verify wireless service in your area and must be performed at the location where the unit is to be installed. A label located on the inside front cover of the monitoring unit is provided to call attention to this process. Figure 2-1 depicts the label noted above.

To verify that cellular service is available at the site, perform the following steps prior to installation:

1. Apply 120 VAC to the unit and then monitor the green LED indicator labeled “ACTIVE” on PCB 9039 for status. See Figure 3-3 for location of the LED. If wireless service is available, the

LED will indicate signal strength by a series of short blinks (1-5).

2. Once a wireless signal is found, the unit will attempt to connect to the NOC. This operation is indicated by rapid blinking of the LED.
3. If communication is achieved, the “ACTIVE” LED will be solid on with short blinks to indicate signal strength (1-5).

**Note:** This process may take several minutes. See Figure 2-1 for complete details of the “Active” LED.

### Finding the Best Install Location

Move the external antenna to different locations to find the maximum signal strength available at the site, as indicated by the number of ACTIVE LED blinks. This will help determine the location where the FTW 175 should be mounted.

Upon successful completion of these steps, shut off power to the unit and proceed with installation.

### ATTENTION

Prior to installation, apply power to the unit and observe the "ACTIVE" LED to verify service. Please note that this sequence may take several minutes to complete.

OFF - Initializing.

OFF with short BLINKS - Wireless network found. Number of short blinks indicates signal strength (1 - 5).

RAPID BLINKING - Communication with NOC underway. Waiting for verification.

ON with short BLINKS - Communication with NOC verified. Number of short blinks indicates signal strength (1 - 5). Begin installation.

Contact the NOC at (800) 821-5825 for technical support.

P/N 3905210  
Rev A

Figure 2-1 – Wireless Service Label

## Section 3 – Mounting and Installation

### **Mounting**

The base of the unit has four (4) mounting feet as shown in Figure 3-4. Mounting hardware is not included.

### **Installation**

#### **AC Power Wiring**

AC Power terminal block TB1 incorporates MOV1 and Fuse F1 for increased protection against AC Power transients. Also, fuseholder TB1 acts as a power disconnect to the unit. Grasp the fuseholder on the sides and pull forward to disconnect power.

Connect 120 VAC power to terminal block TB1 (L, N, GND) as shown in Figure 3-1, but leave power turned off until you are ready for activation (see Section 4). The terminal block uses spring-cage contacts to provide rugged, trouble-free connections which are vibration-proof and gas-tight, thus providing long-term stability. The conductor contact force is determined by the spring tension and so is independent of the user tightening torque as with screw type terminals.

To install a wire, follow these steps:

1. Strip the insulation, exposing **0.4 inch** (10 mm) or more of conductor.
2. Insert a standard 1/8" width screwdriver into the rectangular slot and push. This causes the spring clip to open.
3. Insert the conductor fully into the round terminal compartment and then remove the screwdriver. The conductor automatically makes contact.
4. Check that contact is made to conductor metal and not insulation.

#### **Dry Contact Input Wiring**

Connect the equipment to be monitored via dry contact inputs as shown in Figure 3-3. A label has been provided on the inside cover of the unit to record each input, up to four (4), that is connected. Figure 3-2 depicts the dry contact input label.

#### **RS-485 Wiring**

Connect the equipment to be monitored via RS-485 as shown in Figures 3-5 or 3-6. Figure 3-3 shows the layout of the PCB 9039 board.

#### **Antenna Mounting Bracket**

The supplied Antenna Universal Mounting Bracket Kit (PN 1905355) provides multiple mounting options for the antenna; permitting installation in the optimum location for best signal strength and reliable communication. The bracket's design permits mounting on wall, Uni-strut, or pole (Figure 3-8). Regardless of the mounting method selected, the antenna bracket must be grounded with a minimum 14 AWG ground wire connected to the site grounding system. Observe proper grounding procedures.

The bracket is made from ferrous metal and galvanized for long life. The bracket's top plate accommodates either the magnetic mount or body mount style antenna as shown in Figure 3-7. The cellular antenna must be mounted in the center position of the bracket. The bracket also permits mounting of a photodiode (or photocell) in either of the two side holes on the top plate.

The FTW 175 is shipped with the antenna preinstalled and the antenna cable's SMA connector torqued to specification onto the modem's antenna connector for optimal performance. Do not remove or disconnect unless replacing the modem or antenna.

To install the bulkhead mount style antenna, loosen the antenna mounting nut and washer and slide the antenna mount through the bracket's center hole slot. Tighten the hardware.

**Important:** For best communication performance and to minimize potential for surge damage to the modem radio module, it is very important that the supplied antenna mounting bracket be used for mounting the antenna and that the bracket be grounded with a minimum 14 AWG Ground wire connected to the site Grounding System. Also, if any excess antenna cable is coiled up, the coil diameter must not be less than 18 inches.

### Grounding

To provide increased immunity from lightning damage to the FTW 175, it is essential that the Ground Lug located in the upper left corner of the FTW baseplate (Figure 1-1) be properly connected by a 2 AWG conductor to the site Grounding System. Observe proper Grounding procedures.

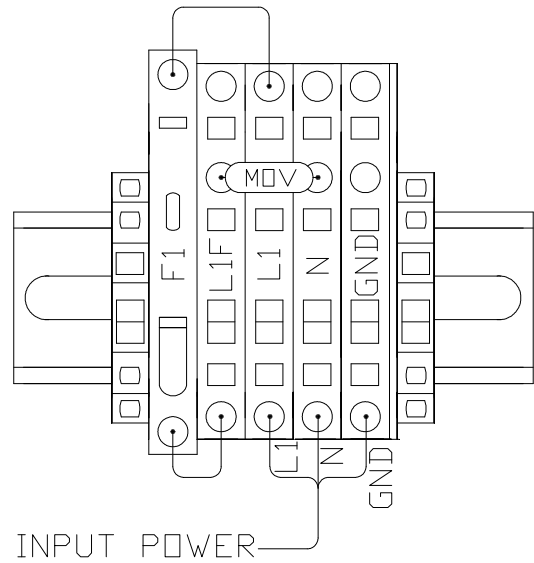

Figure 3-1 – AC Termination

DRY CONTACT INPUTS	
DESCRIPTION	ALARM (CIRCLE ONE)
1 _____	OPEN / CLOSED
2 _____	OPEN / CLOSED
3 _____	OPEN / CLOSED
4 _____	OPEN / CLOSED

Figure 3-2 – Dry Contact Input Label

## Status Indicator LED's

Table 3-1 describes the LED's that are present on the PCB 9039. The location of each LED is shown in Figure 3-3.

Table 3-1 – PCB 9039 LED's

Item	Description
ACTIVE	<b>Off</b> – Initializing. <b>Off with short BLINKS</b> – Wireless Network found. BLINKS indicate signal strength (1-5). <b>Rapid BLINKING</b> – Communication with NOC underway. Waiting for verification. <b>On with short BLINKS</b> - NOC communication verified. BLINKS indicate signal strength (1-5).
232RX	The RS-232 port is receiving data from the modem.
232TX	The RS-232 port is transmitting data to the modem.
485TX	The RS-485 port is transmitting data to the lighting system.
485RX	The RS-485 port is receiving data from the lighting system.
IN1	Dry contact input #1 is closed or shorted.
IN2	Dry contact input #2 is closed or shorted.
IN3	Dry contact input #3 is closed or shorted.
IN4	Dry contact input #4 is closed or shorted.

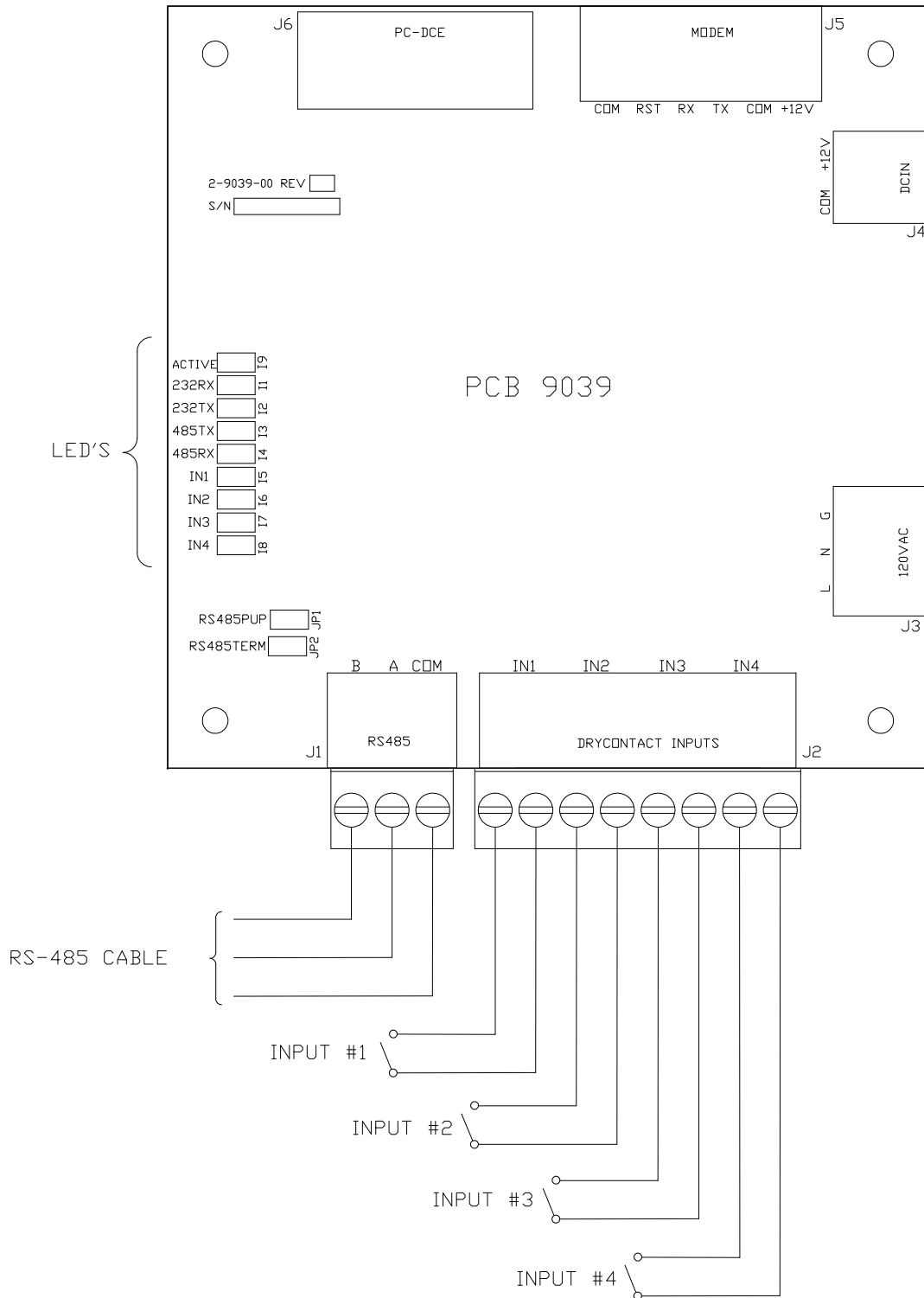
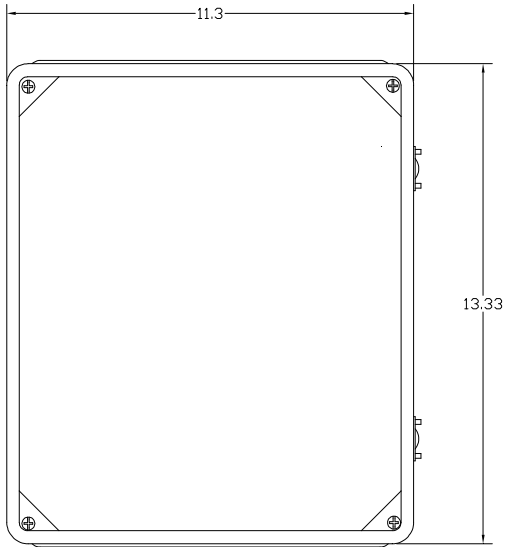
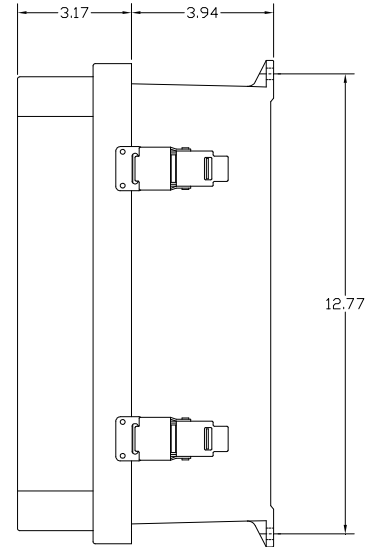

Figure 3-3 – PCB 9039 Layout and External Wiring

FRONT VIEW



RIGHT SIDE VIEW



BOTTOM VIEW

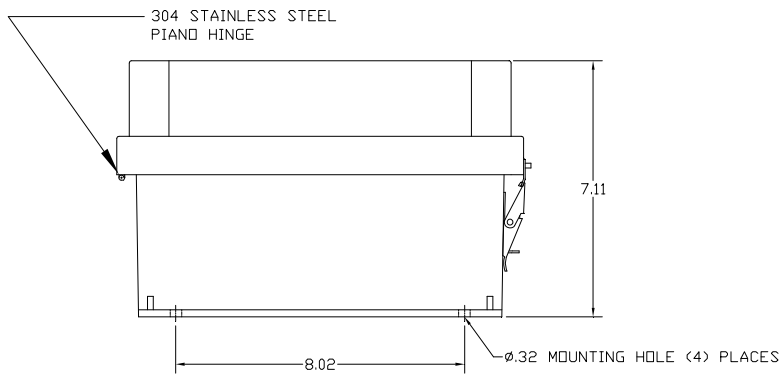

Figure 3-4 – Enclosure Mounting Footprint

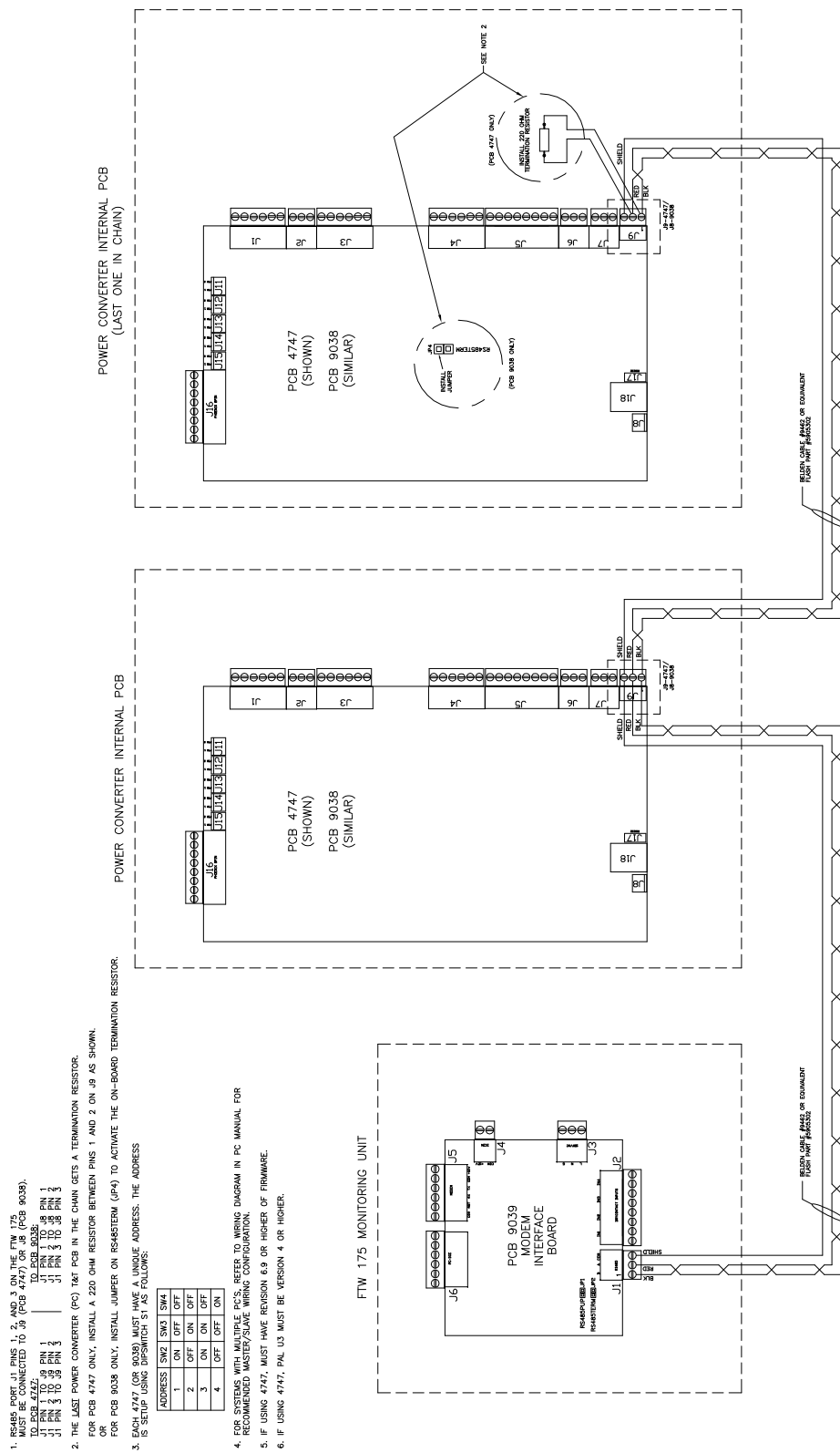

Figure 3-5 – RS-485 Installation with FTB Strobe System

NOTES:  
 RS485 PORT J1 PINS 1, 2 AND 3 ON THE FTW 175 MUST BE CONNECTED TO J2 PINS 1, 2 AND 3 ON THE 36XX CONTROLLER.  
 FTW 174  
 J1 PIN 1 TO J2 PIN 1  
 J1 PIN 2 TO J2 PIN 2  
 J1 PIN 3 TO J2 PIN 3

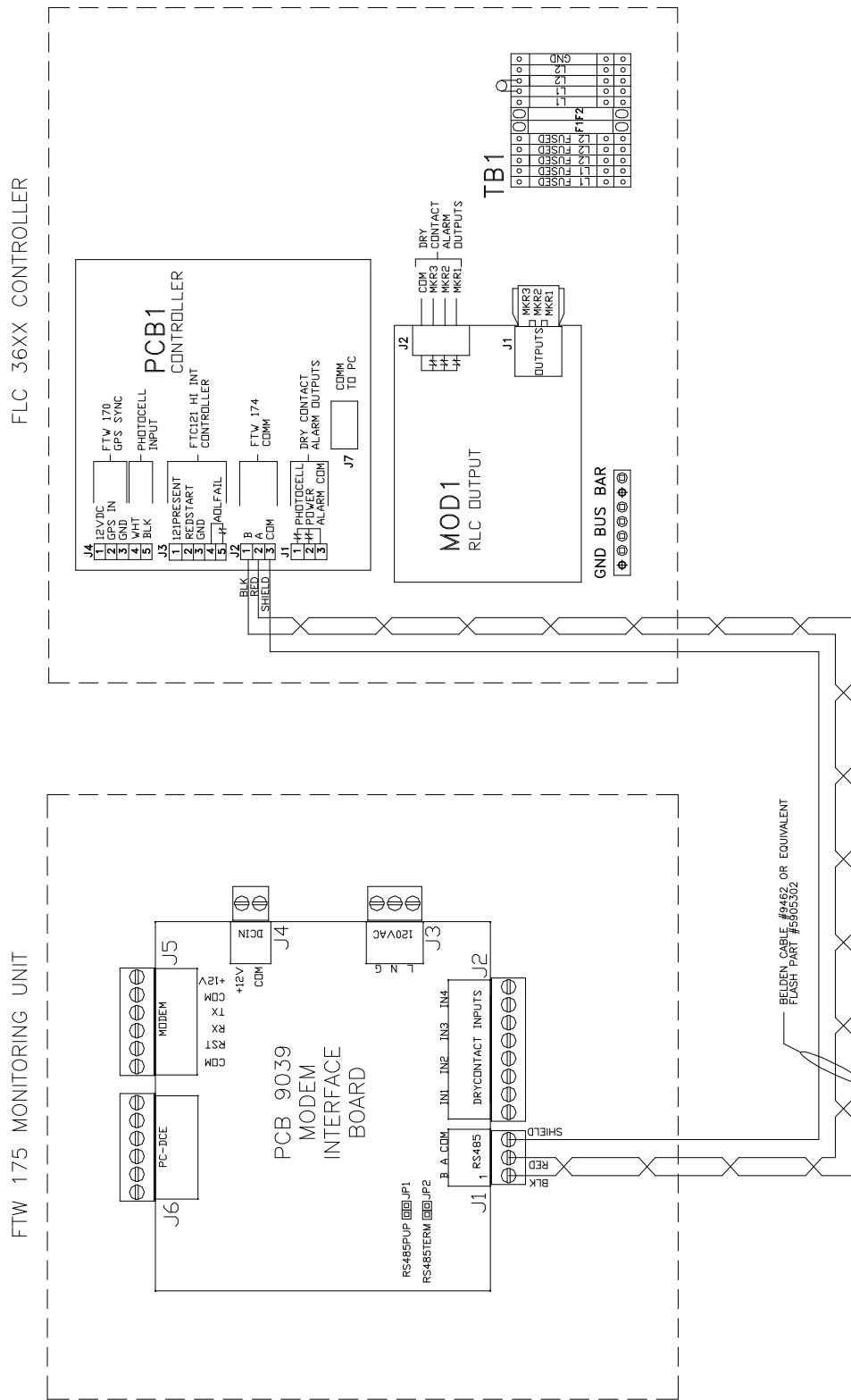
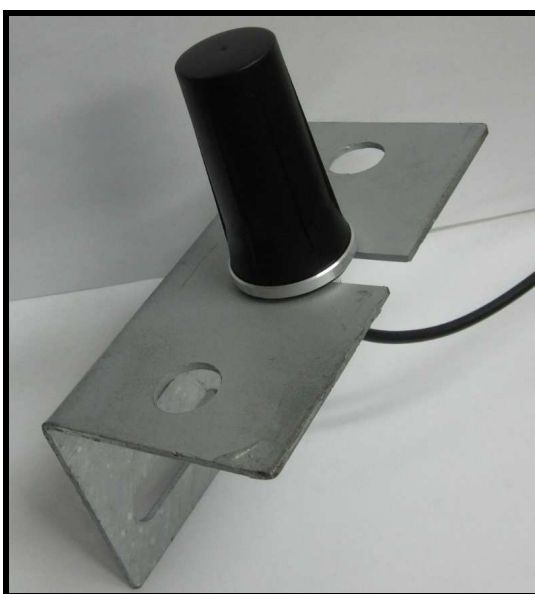

Figure 3-6 – RS-485 Installation with FLC 36XX





Magnetic Mount Antenna



Body Mount Antenna

Figure 3-7 – Antenna Types



Wall Mount

Use screws to mount to the inside or outside wall of a shelter.

*(Screws are not included in the kit.)*



Horizontal Uni-strut Mount

Use spring-nuts to mount to Uni-strut.

*(Spring-nuts are not included in the kit.)*



Vertical Pole or H-frame post Mount

Use 3" U-bolt (*included*) to mount to pole or H-frame post. The bracket permits use of larger U-bolts, up to 5".

Figure 3-8 – Antenna Universal Mounting Bracket

**Note:** Dual band magnetic mount antenna shown.

## Section 4 – Activation

### Monitoring

**Important: Before leaving the site, ensure that the battery is connected.**

**When removing power from the equipment, ensure that the red wire to the battery is disconnected first. Reconnect battery after work is completed.**

Once the installation is complete, follow the procedure below to activate the service and begin monitoring:

1. Before calling the NOC, please be prepared to provide the following information:
  - The wireless number for this unit. See Figure 4-1. The label is located on the inside front cover.
  - Your name, contact number and company.
  - If monitoring an FCC registered tower site, the site number and FCC number.
  - Descriptions of the items being monitored by each input.
2. Re-apply power to the equipment and observe the “Active” LED shown in Figure 3-3. Once the LED is “On with short BLINKS”, communication with the NOC has been established. This process may take several minutes. Refer to Figure 2-1 and Table 3-2 for complete details of the “Active” LED.
3. Secure the external antenna on the Antenna Mounting Bracket in a location which provides maximum signal strength as indicated by the number of ACTIVE LED blinks
4. Connect the red wire to + (Positive) and the black wire to – (Negative) on the battery as shown in Figure 1-1.
5. Call 1-800-821-5825 to initiate monitoring while on-site. The NOC technician will request several tests to be performed to verify correct installation and operation of the system.
6. Please note that once the unit is powered and communication is established, it will automatically send a message to the NOC to initiate service and billing will begin.



**IP 10.243.16.1**

Figure 4-1 – Wireless Number

## Section 5 – Recommended Spare & Replaceable Parts

### Customer Service

Customer Service: (800) 821-5825

Telephone: (615) 261-2000

Facsimile: (615) 261-2600

Shipping Address:

Flash Technology  
332 Nichol Mill Lane  
Franklin, TN 37067

### Ordering Parts

To order spare or replacement parts, contact customer service at 1-800-821-5825.

Table 5-1 – Major Replaceable Parts

Reference	Description	Part Number
MODEM	Modem Wireless, Verizon	5905204
	Modem Wireless, AT&T	5905205
HARNESS	Harness, FTW 175 Modem Signal	4905286
BATTERY	12V Battery	4991875
POWER	Power Supply	5905202
POWER	Fuse 2 Amp Slow Blow 5x20 mm	11000008012
PCB 9039	FTW 175 PCB	2903912
MODEM RESET	Modem Reset PCB	2903920
ANTENNA	Dual Band Magnetic Mount	4905227
	Wide Band Body Mount	4905230
ANTENNA	Kit Antenna Mounting Bracket	1905355
TB1	FUSE 3 AMP 3AB	4150218
TB1	Varistor 130V	6901079

Table 5-2 – Optional Items

Reference	Description	Part Number
CABLE	RS-485; Single Pair, 22 AWG, Red/Black	5905302
CABLE	Dry Contacts; 4 Pair, 22 AWG, Red/Black	5993101

## Return Material Authorization (RMA) Policy

IF A PRODUCT PURCHASED FROM FLASH TECHNOLOGY MUST BE RETURNED FOR ANY REASON (SUBJECT TO THE WARRANTY POLICY), PLEASE FOLLOW THE PROCEDURE BELOW:

**Note:** An RMA number must be requested from Flash Technology prior to shipment of any product. No returned product will be processed without an RMA number. This number will be the only reference necessary for returning and obtaining information on the product's progress. Failure to follow the below procedure may result in additional charges and delays. Avoid unnecessary screening and evaluation by contacting Technical Support prior to returning material.

1. **To initiate an RMA: Call Flash Technology's National Operations Center (NOC) at (800-821-5825) to receive technical assistance and a Service Notification number. The following information is required before a Service Notification number can be generated:**
  - Site Name/Number / FCC Registration number/ Call Letters or Airport Designator
  - Site Owner (provide all that apply – owner, agent or subcontractor)
  - Contractor Name
  - Contractor Company
  - Point of Contact Information: Name, Phone Number, Email Address, Fax Number and Cell Phone (or alternate phone number)
  - Product's Serial Number
  - Product's Model Number or part number
  - Service Notification Number (if previously given)
  - Reason for call, with a full description of the reported issue
  
2. **The Service Notification number will then serve as a precursor to receiving an RMA number if it is determined that the product or equipment should be returned. To expedite the RMA process please provide:**
  - Return shipping method
  - Shipping Address
  - Bill to Address
  - Any additional information to assist in resolving the issue or problem
  
3. **Product within the Warranty Time Period**
  - a. If to be returned for repair;
    - RMA # is generated
    - Once product is received and diagnosed;
      - Covered under warranty – product is repaired or replaced
      - Not covered under warranty – quote is sent to the customer for a bench fee of **\$350 plus parts** for repair
        - If the customer does not want the product repaired, a **\$50 test fee** is charged before being returned
  - b. If advance replacement;
    - Purchase order may be required before the advance replacement order is created
    - RMA # is generated and the advance replacement order is created
    - Once product is received and diagnosed;
      - Covered under warranty – credit given back if PO received
      - Not covered under warranty – credit **will not** be applied to PO
    - Flash Technology has sole discretion in determining warranty claims. Flash Technology reserves the right to invoice for parts advanced if the associated failed parts are not returned within 15 days of issue or if product received is diagnosed to be non-warranty.

- Advance replacements will be shipped ground unless the customer provides alternative shipping methods.

#### 4. Product outside the Warranty Time Period

- a. For Xenon System board repair; a purchase order is required at time of request for a RMA # for a standard **\$350 repair bench fee**
  - RMA # is generated with the PO attached
  - If the board is deemed non-repairable after diagnosis, the customer is notified. If the customer purchases a new board, the repair bench fee is waived. If the customer does not buy a new board, a **\$50 test fee** is charged before being returned or scrapped.
- b. For all other products; no purchase order is required to return the product for diagnosis
  - RMA # is generated
  - Once product is diagnosed, quote is sent to the customer for a bench fee of **\$350 plus parts** for repair
  - Once the purchase order is received, the product will be repaired and returned
    - If the customer does not want the product repaired, a **\$50 test fee** is charged before being returned or scrapped.

#### 5. After receiving the Flash Technology RMA number, please adhere to the following packaging guidelines:

- All returned products should be packaged in a way to prevent damage in transit. Adequate packing should be provided taking into account the method of shipment.

**Note: Flash Technology will not be responsible for damaged items if product is not returned in appropriate packaging.**

#### 6. All packages should clearly display the RMA number on the outside of all RMA shipping containers. RMA products (exact items and quantity) should be returned to:

Flash Technology  
Attn: RMA #XXX  
332 Nichol Mill Lane  
Franklin, TN 37067

#### 7. All RMA numbers:

- Are valid for 30 days. Products received after 30 days may result in extra screening and delays.
- Must have all required information provided before an RMA number is assigned.