



SN

**FIV 600, FIV 1100 AND FIV 2000**

---

**Power Inverter Manual**

# Front Matter

## Abstract

This document describes the FIV 600,1100 and FIV 2000 Power Inverters.

## Copyright

Copyright © 1995 - 2002, Flash Technology Corporation of America®, Franklin TN 37064, U.S.A.

All rights reserved. Reproduction or use of any portion of this manual is prohibited without express written permission from Flash Technology Corporation of America and/or its licensor.

## Trademark Acknowledgments

Flash Technology Corporation of America® is a registered trademark name.

ElectroFlash™, Flash Tech™, Flash Technology™, FTCA™, and the Flash Technology Logo are all trademarks of Flash Technology Corporation of America®.

All trademarks and product names mentioned are properties of their respective companies, and are recognized and acknowledged as such by Flash Technology Corporation of America.

## Disclaimer

While every effort has been made to ensure that the information in this manual is complete, accurate and up-to-date, Flash Technology Corporation of America assumes no liability for damages resulting from any errors or omissions in this manual, or from the use of the information contained herein. Flash Technology Corporation of America reserves the right to revise this manual without obligation to notify any person or organization of the revision.

In no event will Flash Technology Corporation of America be liable for direct, indirect, special, incidental, or consequential damages arising out of the use of or the inability to use this manual.

## Warranty

FTCA warrants all components, under normal operating conditions, for two years.

## Parts Replacement

The use of non-OEM parts or unauthorized modification of this equipment will void the warranty

Pub. No. 0594-FIV1100/2000-3

## PERSONNEL HAZARD WARNING

### DANGEROUS VOLTAGES

Dangerous line voltages reside in certain locations in this equipment. Also, this equipment may generate dangerous voltages. Although FTCA has incorporated every practical safety precaution, exercise extreme caution at all times when you expose circuits and components, and when you operate, maintain, or service this equipment.

### Avoid Touching Live Circuits

Avoid touching any component or any part of the circuitry while the equipment is operating. Do not change components or make adjustments inside the equipment with power on.

### Do Not Depend on Interlocks

Never depend on interlocks alone to remove unsafe voltages. Always check circuits with a voltmeter. Under no circumstances remove or alter any safety interlock switch.

## Table of Contents

Section	Page
<b>Section 1 FIV 600, FIV 1100 and FIV 2000 Reference</b> .....	<b>1-1</b>
FIV600, FIV 1100 and FIV 2000 Description .....	1-1
FIV 600,1100 and FIV 2000 Operation .....	1-1
Power Inverter Protection Operation .....	1-1
Installation .....	1-1
Troubleshooting .....	1-5
FIV 600,1100 and FIV 2000 Parts and Locations .....	1-5
<b>Index</b> .....	<b>I-1</b>

## List of Figures

Figure	Page
2-1 FIV 600,1100 or FIV 2000 Mounting and Outline .....	1-2
2-2 FIV 600,1100 Typical Installation Wiring .....	1-3
2-3 FIV 2000 Typical Installation Wiring .....	1-4
2-4 FIV 600,1100 or FIV 2000 Component Locations .....	1-6
2-5 FIV 600,1100 or FIV 2000 Internal Wiring .....	1-7

## List of Tables

Table	Page
1-1 Troubleshooting Table .....	1-5
1-2 FIV 600,1100 and FIV 2000 Parts and Locations .....	1-5

# Preface

Please read this Preface and the rest of this manual carefully to ensure correct usage and maintenance of the system. Flash Technology Corporation of America® (FTCA) recommends that you keep this manual near the system for your easy reference.

## NOTE

Warning labels on the equipment are important. Warning notices in this manual are equally important. See the subsection in this Preface entitled *Personnel Hazard Warning Notice*.

## Purpose and Scope of the Manual

This manual contains information and instructions for installing, operating, and maintaining ElectroFlash™ FIV 600,1100 and FIV 2000 Power Inverters manufactured by Flash Technology Corporation of America® (FTCA).

## Troubleshooting

Call 1-800-821-5825 for consultation and repair assistance.

## Returning Equipment

Contact Customer Service to obtain a Return Material Authorization (RMA) number.

## Ordering Spare Parts

Contact Customer Service and order parts using diagrams and part numbers listed in Section *FIV 600,1100 and FIV 2000 Parts and Locations* on Page 1-5 of this manual.

## Customer Service

Customer Service 1-800-821-5825  
FTCA Telephone: (615) 261-2000  
Facsimile: (615) 261-2600  
Internet Address: <http://www.flashtechnology.com>  
Shipping Address: Flash Technology Corporation of America  
332 Nichol Mill Lane  
Franklin TN 37067

# Section 1 FIV 600, FIV 1100 and FIV 2000 Reference

---

## FIV 600, FIV 1100 and FIV 2000 Description

The FIV 600, FIV 1100 and FIV 2000 Power Inverters provide automatic battery backup power source connection if primary AC power fails.

All of the FIVs are typically connected to a battery source and to the primary 120 VAC power source. It provides 120 VAC power for between either a single or a triple medium intensity power converter.

The FIV 600 can provide power for a single medium intensity power converter requiring up to 600 VA peak. The FIV 1100 can supply between 600 VA to 1100 VA peak. The FIV 2000 can provide power for three medium intensity power converters.

## **FIV 600,1100 and 2000 Operation**

The FIV 600,1100 and 2000 Power Inverters operate as follows:

- Normal Operation — Line power active
  - AC source power energizes the transfer relay in the FIV, which applies the 120 VAC source power to the power converter.
- Battery Back-up Operation — Line power interrupted
  - If AC source power is interrupted, the transfer relay de-energizes allowing 24 VDC battery power to be applied to the power inverter. The power inverter then changes the 24 VDC to 120 VAC  $\pm 5\%$  at 60 Hz  $\pm 1\%$  and applies the resulting AC power to the power converter.

## **Power Inverter Protection Operation**

The following protection features are incorporated into the FIVs:

**Low Battery Voltage:** Low battery voltage causes the inverter to shut off. Low battery voltage can be caused by corroded terminals or an old battery. Restoring battery voltage causes the inverter to restart.

**High Battery Voltage:** High battery voltage (incorrect battery connections or batteries) causes the inverter to shut off. Restoring the correct operating voltage causes the inverter to restart.

**Over-temperature:** If the inverter overheats, it shuts off. Restoring reasonable operating temperatures causes the inverter to restart.

**Overpower:** If the load requires power higher than the rating of the inverter, the inverter lowers its output voltage to supply no more than its rated power. Restoring the proper load on the inverter restores the operating voltage.

## Installation

Follow the installation instructions described in this manual in the installation wiring, and mounting and outline, drawings of the FIV units. Use the following information:

- Installation drawings prepared especially for your site, which take precedence over drawings in this manual
- Installation drawings in this manual in Figure 2-1 *FIV 600,1100 or FIV 2000 Mounting and Outline* on Page 1-2, Figure 2-2 *FIV 600 and 1100 Typical Installation Wiring* on Page 1-3, and Figure 2-3 *FIV 2000 Typical Installation Wiring* on Page 1-4.

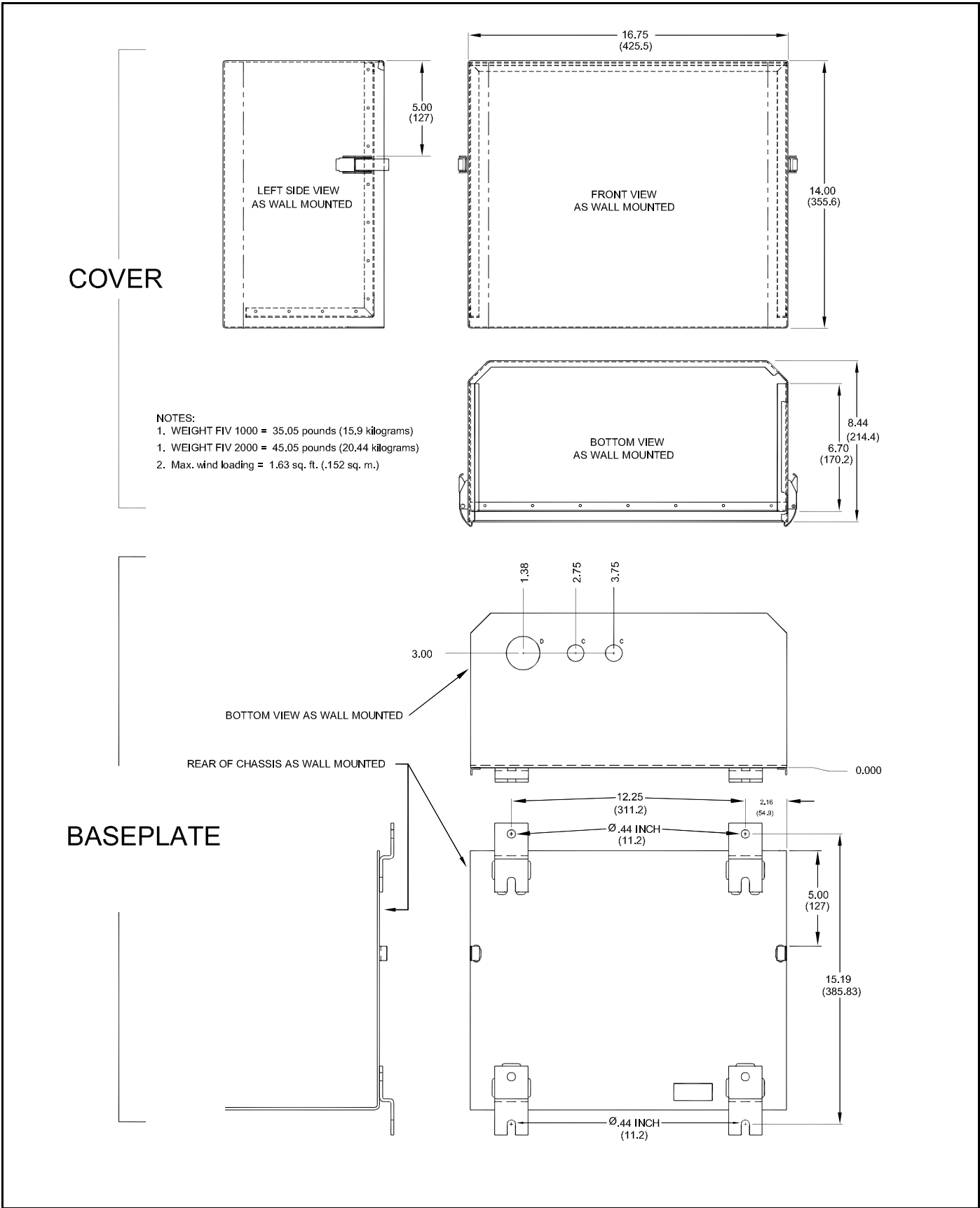

FIV1100MO

Figure 2-1 FIV 600,1100 or FIV 2000 Mounting and Outline

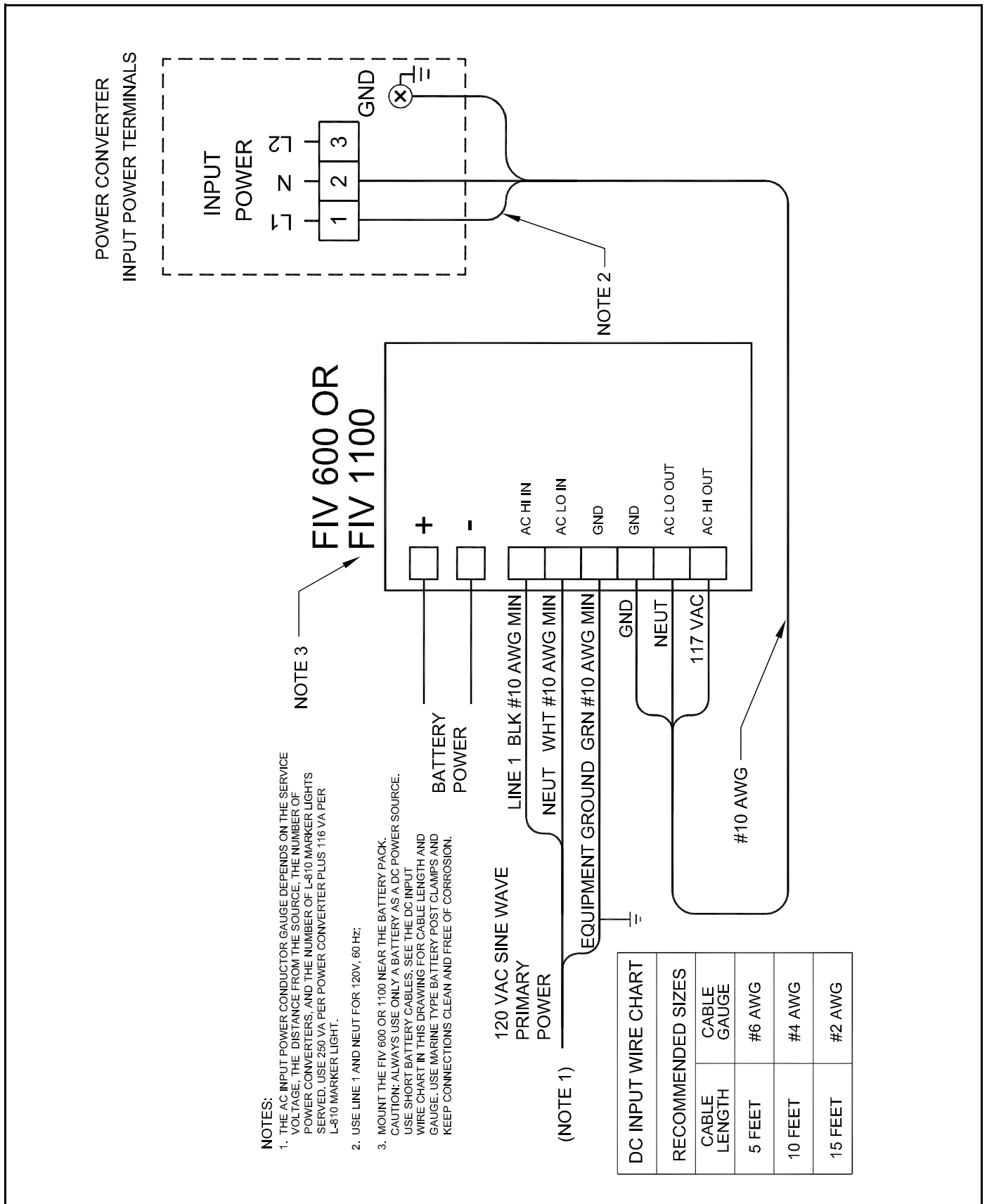
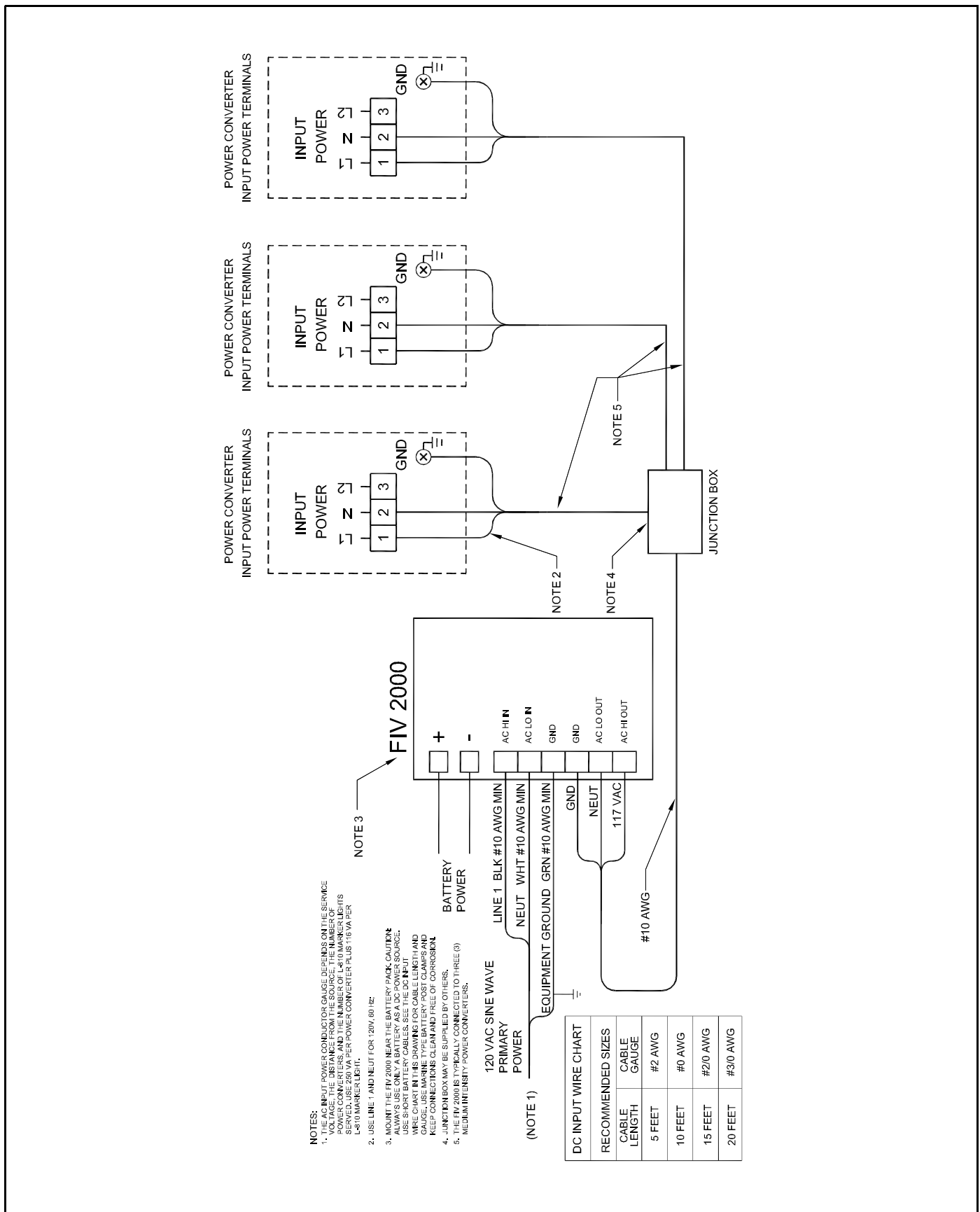

Figure 2-2 FIV 600 and 1100 Typical Installation Wiring



FIV2000IW

Figure 2-3 FIV 2000 Typical Installation Wiring

# Troubleshooting

The following *Table 1-1* is a guide to help you troubleshoot the FIV unit. Internal wiring is shown in *Figure 2-5*. Also, use the following hints:

- Check that the AC power source is really off.

- Check the battery voltage under load with a battery tester.
- Check the AC output voltage of the FIV. With the AC power source off, and the battery OK, the FIV should produce 120 VAC at 60Hz.

**Table 1-1 Troubleshooting Table**

AC Power	Power Converter	Battery	FIV AC Out	Relay	Problem
OK	OK	OK	None	Energized	None
OK	OK	Low	None	Energized	None with AC; DC power will not function
OK	Not operating	OK	None	Energized	Relay in FIV is defective
Off	OK	OK	120 VAC 60Hz	De-energized	None with DC; AC power does not operate power converter — FIV operating correctly
Off	Not operating	Low	None	De-energized	Battery
Off	Not operating	OK	None	De-energized	Relay or power inverter in FIV
Off	Not operating	OK	120 VAC 60Hz	De-energized	Power converter

## FIV 600,1100 and FIV 2000 Parts and Locations

The part numbers for the FIV 1100 and FIV 2000 Power Inverters are shown in *Table 1-2*. Component locations are shown in *Figure 2-4*.

**Table 1-2 FIV 600,1100 and FIV 2000 Parts and Locations**

Component	Description	Part Number
K1	Power Transfer Relay	4900493
S1	Thermostat	4902589
VC-1	DC to AC 1100W Inverter	4802583
VC-1	DC to AC 2000w Inverter	4802584
TB1	Terminal Block, 6-position	4902257
B1	Blower	4902588
VC-1	DC to AC 600W Inverter	4903281

# FIV 600/1100/2000 COMPONENT LOCATIONS

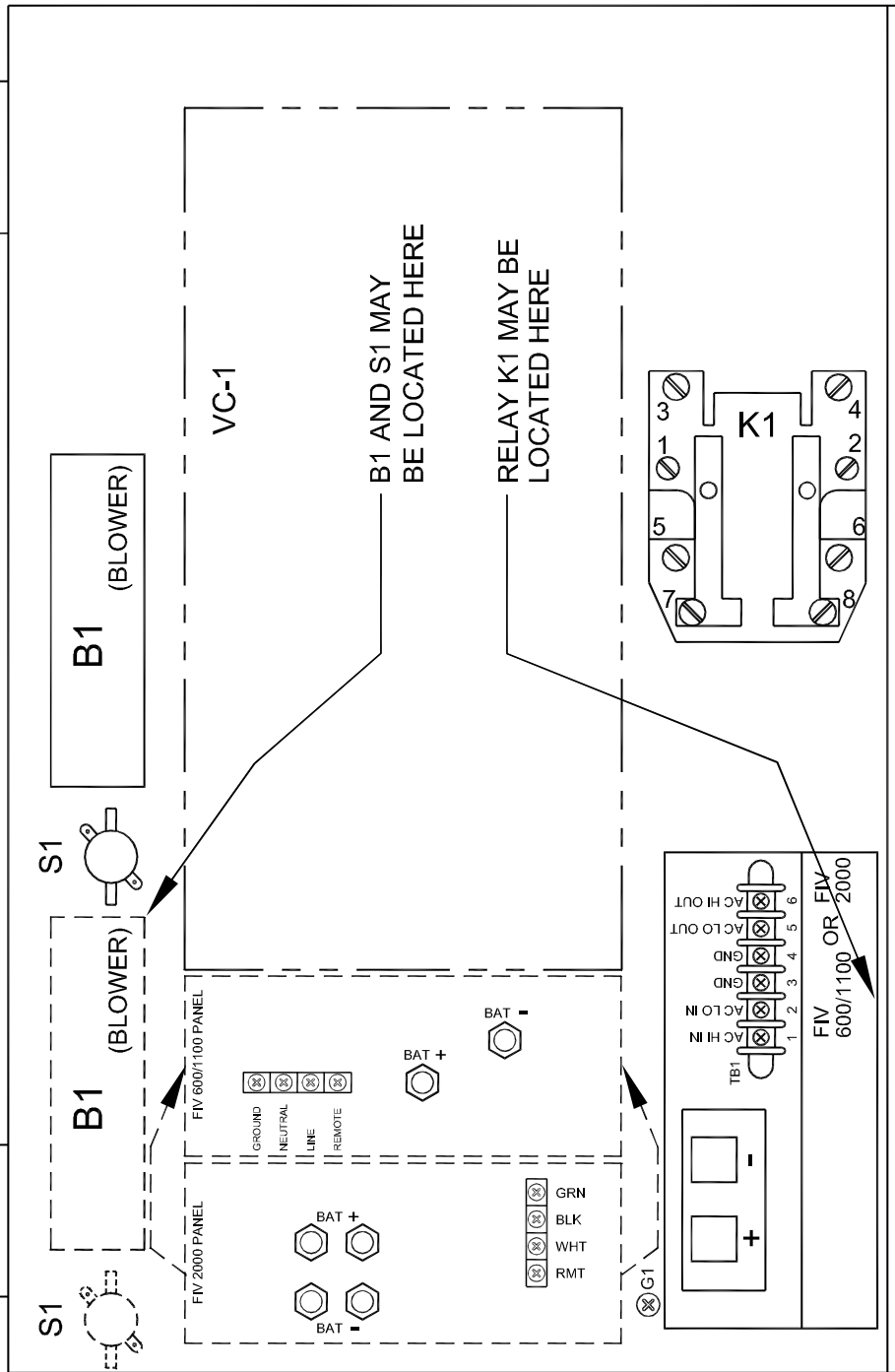

FV1100CL

Figure 2-4 FIV 600,1100 or FIV 2000 Component Locations

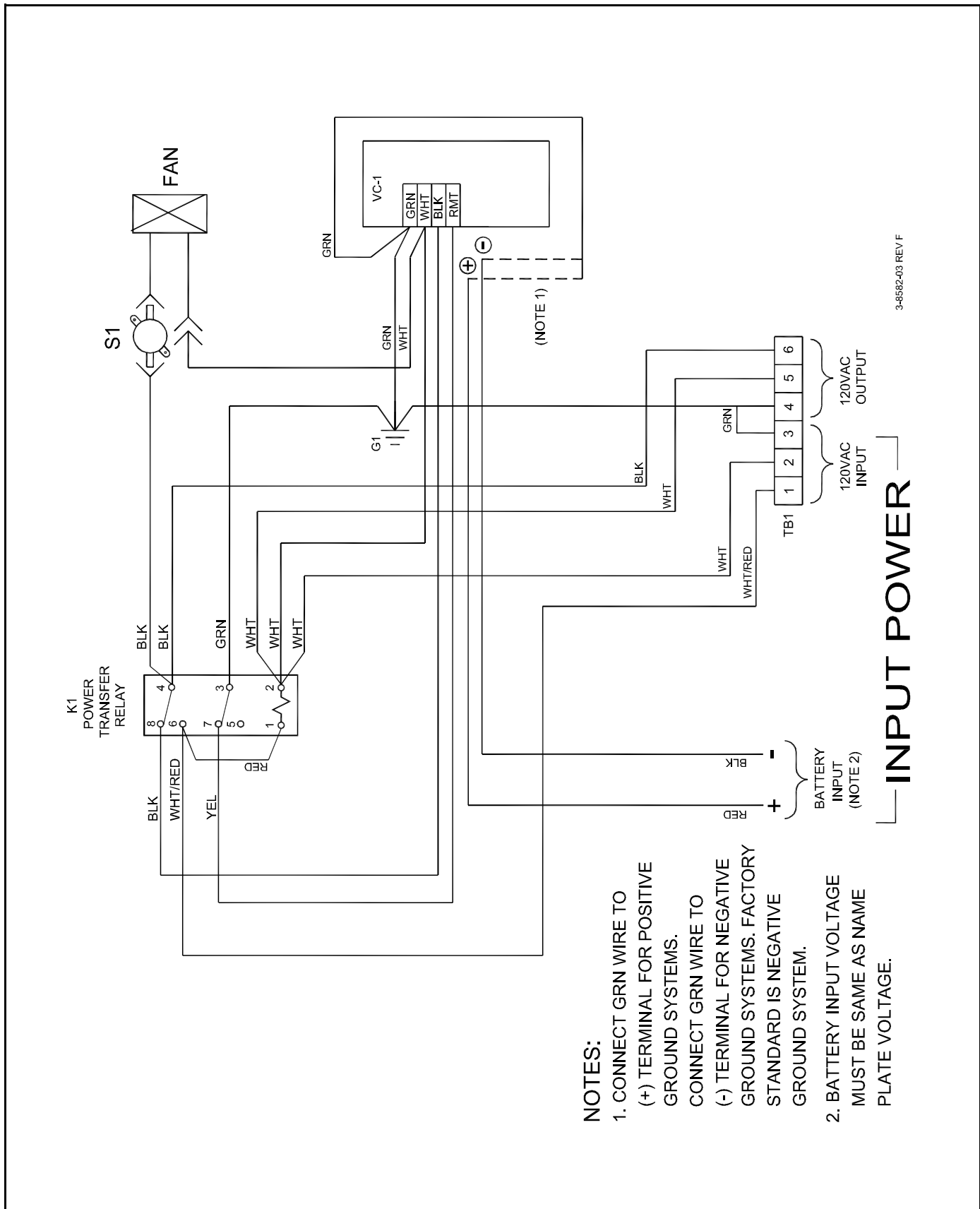

3-8582-03 REV F

**NOTES:**

1. CONNECT GRN WIRE TO (+) TERMINAL FOR POSITIVE GROUND SYSTEMS. CONNECT GRN WIRE TO (-) TERMINAL FOR NEGATIVE GROUND SYSTEMS. FACTORY STANDARD IS NEGATIVE GROUND SYSTEM.
2. BATTERY INPUT VOLTAGE MUST BE SAME AS NAME PLATE VOLTAGE.

**Figure 2-5 FIV 600,1100 or FIV 2000 Internal Wiring**

**This page is intentionally blank.**

## **Index**

### **C**

Component locations  
    FIV 600,1100 1-6  
    FIV 2000 1-7

Copyright ii

### **D**

Disclaimer ii

### **F**

FIV 600,1100  
    component locations 1-6  
    mounting and outline 1-2  
    parts 1-5  
FIV 600,1100 description 1-1  
FIV 600,1100 operation 1-1  
FIV 2000  
    component locations 1-7  
    installation wiring 1-4  
    mounting and outline 1-2  
    parts 1-5  
FIV 2000 description 1-1  
FIV 2000 operation 1-1

### **I**

Installation

    FIV 600,1100 and FIV 2000 System 1-1  
Installation wiring  
    FIV 1100 1-3

### **M**

Manual abstract ii  
Mounting and outline  
    FIV 1100 or FIV 2000 1-2

### **O**

Operation  
    FIV 600,1100 1-1  
    FIV 2000 1-1

### **P**

Parts  
    FIV 600,1100 and FIV 2000 1-5  
Parts replacement ii

### **T**

Trademark acknowledgment ii  
Troubleshooting 1-5

### **W**

Warranty ii  
Wiring  
    installation  
        FIV 600,1100 1-3  
        FIV 2000 1-4

This page is intentionally left blank.

— End of Document —