



SERIAL NUMBER

FTB 622

**Ultra High Intensity Strobe Wave-Off Light
Reference Manual
P/N # 7916220**

Front Matter

Abstract

This manual contains information and instructions for installing, operating and maintaining the FTB 622 Ultra High Intensity Wave-Off Light.

Copyright

Copyright © 2009, Flash Technology®, Franklin, TN, 37067, U.S.A.

All rights reserved. Reproduction or use of any portion of this manual is prohibited without express written permission from Flash Technology and/or its licensor.

Trademark Acknowledgements

Flash Technology® is a registered trademark name.

ElectroFlash™, Flash Tech™, Flash Technology™, FTCA™, Flash™ and the Flash Technology Logo are all trademarks of Flash Technology.

All trademarks and product names mentioned are properties of their respective companies, and are recognized and acknowledged as such by Flash Technology.

Applicable Specifications

This equipment meets or exceeds requirements for a Military Air Systems Specification MIL-L-29575 (AS).

Disclaimer

While every effort has been made to ensure that the information in this manual is complete, accurate and up-to-date, Flash Technology assumes no liability for damages resulting from any errors or omissions in this manual, or from the use of the information contained herein. Flash Technology reserves the right to revise this manual without obligation to notify any person or organization of the revision.

In no event will Flash Technology be liable for direct, indirect, special, incidental, or consequential damages arising out of the use of or the inability to use this manual.

Warranty

Flash Technology warrants all components, under normal operating conditions, for two years.

Parts Replacement

The use of parts or components, in this equipment, not manufactured or supplied by Flash Technology voids the warranty and invalidates the third party testing laboratory certification which ensures compliance with Military Air Systems Specification MIL-L-29575 (AS).

Personnel Hazard Warning

Dangerous Voltages

Dangerous line voltages reside in certain locations in this equipment. Also, this equipment may generate dangerous voltages. Although FTCA has incorporated every practical safety precaution, exercise extreme caution at all times when you expose circuits and components, and when you operate, maintain, or service this equipment.

Avoid Touching Live Circuits

Avoid touching any component or any part of the circuitry while the equipment is operating. Do not change components or make adjustments inside the equipment with power on.

Dangerous Voltages Can Persist with Power Disconnected

Under certain conditions, dangerous voltages can be present because capacitors can retain charges even after the power has been disconnected.

Protect yourself — always turn off the input (primary) power and wait for one minute for storage capacitors to drain their charge. Then check between the red and blue wires on the flashhead terminal block with a voltmeter for any residual charge before touching any circuit element or component.

Do Not Depend on Interlocks

Never depend on interlocks alone to remove unsafe voltages. Always check circuits with a voltmeter. Under no circumstances remove or alter any safety interlock switch.

Table of Contents

FTB 622	i
Ultra High Intensity Strobe Wave-Off Light	i
Reference Manual	i
P/N # 7916220	i
Front Matter	ii
Abstract	ii
Copyright	ii
Trademark Acknowledgements	ii
Applicable Specifications	ii
Disclaimer	ii
Warranty	ii
Parts Replacement	ii
Personnel Hazard Warning	iii
Dangerous Voltages	iii
Avoid Touching Live Circuits	iii
Dangerous Voltages Can Persist with Power Disconnected	iii
Do Not Depend on Interlocks	iii
Table of Contents	iv
List of Figures	vi
List of Tables	vi
Section 1 – FTB 622 Introduction and Operation	1
System	1
Specifications	1
Physical	1
Performance Characteristics	1
Options and Variations	1
Operation	1
Section 2 – Outline, Mounting and Installation	3
Unpacking	3
Tools	3
Access	3
Power Converter	3
Flashhead	3
Mounting	3
Power Converter	3
Flashhead	3
Installation	3
Power Converter Wiring	4
Flashhead Wiring	4
Installation Checklist	4
Section 3 – Maintenance and Troubleshooting	12
Safety	12
Preventive Maintenance	12
Storage	12
RFI Problems	12

Component Testing.....	12
Capacitors	12
Wiring and Cabling.....	13
Inspection.....	13
Power Converter	13
Flashhead	14
Component Removal and Replacement.....	14
Power Converter Components	14
Flashhead Components	15
Operational Checkout	16
Intensity.....	16
PCB1 Indicator Lamps.....	16
Troubleshooting	16
Section 4 – Replaceable and Spare Parts	19
Customer Service	19
Ordering Parts	19
Power Converter Parts	19
Flashhead Parts	19
Returning Equipment	19
Repackaging.....	19
Power Converter	19
Flashhead	19
RETURN MATERIAL AUTHORIZATION (RMA) POLICY.....	23

List of Figures

Figure 2-1 Typical System Configuration	6
Figure 2-2 Power Converter Mounting and Outline	7
Figure 2-3 Flashhead Mounting and Outline	8
Figure 2-4 Typical Installation Wiring	9
Figure 2-5 Power Converter Internal Wiring.....	10
Figure 2-6 Flash head Internal Wiring.....	11
Figure 4-1 Power Converter Component Layout.....	21
Figure 4-2 Flashhead Component Layout.....	22

List of Tables

Table 3-1 Power Transformer Voltages.....	14
Table 3-2 PCB1 Indicators.....	16
Table 3-3 Troubleshooting Symptoms.....	17
Table 3-4 Fault Locator	17
Table 4-1 Power Converter Major Replaceable Parts.....	20
Table 4-2 Flashhead Major Replaceable Parts.....	22

Section 1 – FTB 622 Introduction and Operation

FTB 622 Ultra High Intensity Strobe Wave-Off Lights, often called Navy wave-off lights, signal aircraft approaching a runway where conditions are not suitable for a landing.

The lights meet or exceed all requirements of Military Air Systems Specification MIL-L-29575 (AS).

System

The FTB 622 consists of a power converter and a flashhead interconnected by an electrical cable. They can be separated by up to 150 feet without any noticeable diminution of light.

The power converter uses power from an AC source, produces discharge energy to the flashtube, and contains components and circuitry to control flashing. It is usually installed at ground level on three supporting pipes secured to a concrete pedestal. The stainless steel mounting bracket receives three 2-inch mounting pipes. The flashhead uses one layer of clear impact resistant glass and another of red filter glass.

Specifications

Physical

Power Converter

Height x Width x Depth x Weight (inches and millimeters and kilograms):

22 in. x 20 in. 14 in. x 86 lbs.

558.8 mm. x 508 mm. x 355.6 mm. x 38.9 kg.

Flashhead

Height x Width x Depth x Weight (inches and millimeters and kilograms):

22 in. x 21 in. x 12 in. x 36 lbs.

558.8 mm. x 533.4 mm. x 304.8 mm. x 16.3 kg.

Performance Characteristics

Light Output High Intensity

800,000 Cd¹ minimum (white)

50,000 Cd¹ minimum (red)

Light Output Low Intensity

80,000 Cd¹ minimum (white)

5,000 Cd¹ minimum (red)

Beam Spread

10 degrees minimum conical angle

Electrical

Voltage 480 VRMS, 60 Hz standard

Volt-Amperes 1,000 (at highest intensity)

Watts 550 (at highest intensity)

Intensity Switching

External switch closure; isolated contact

Environmental

-50 to +55 degrees centigrade

Options and Variations

120 or 240 VAC 60 Hz; or, 230 VAC 50 Hz

Operation

These lights produce a rapid sequence of intense flashes in a directional beam. A typical installation consists of several lights flashing simultaneously.

1. Sections 4.6.3.1 to 4.6.3.3, *Effective Intensity, MIL-L-29575 (AS)*.

The lights begin to operate at a rate of 90 flashes per minute as soon as primary power is switched on. The intensity of the flashes is approximately 800,000 candelas (white) in a cone-shaped beam with a minimum of 10 degrees divergence (5 degrees from the axis).

An optional external switch can reduce the flash intensity to about 80,000 candelas (white) for nighttime operation. When this switch is used, a lock-out circuit prevents the flash intensity from changing part way

through a wave-off sequence. After using the switch, turn off the power, then re-apply the power for the new intensity setting to take effect.

The red filter reduces the visible light intensity in the red light beam to about 50,000 and 5,000 candelas, respectively, for the high and low intensity settings. Any number of lights will flash simultaneously if primary power is supplied to all lights at the same instant.

Section 2 – Outline, Mounting and Installation

Unpacking

Inspect shipping cartons for signs of damage before opening them. Check package contents against the packing list and inspect each item for visible damage. Report damage claims promptly to the freight handler.

Tools

Although no special tools are necessary, FTCA suggests the following hand tools for installation and maintenance:

- 9- or 12-inch, flat-blade #2 screwdriver
- #2 Phillips®-head screwdriver
- Medium, slip joint pliers
- Set of combination wrenches
- Long-nose pliers
- Assorted nut driver handles: 1/4", 5/16", 3/8" recommended
- Multi-purpose crimp tool
- Spanner or large pliers for two-inch NPT locking nuts
- Triplet™ Model 630-NA VOM, or equivalent analog volt-ohm meter

Access

Power Converter

The cover is secured by four stainless steel latches. When these have been released, the cover can be tilted back, opening the power converter for internal access.

Flashhead

WARNING

The flashhead contains no interlock. Do not remove any flashhead panels unless primary power has been disconnected from the power converter. Wait five minutes for storage capacitors to drain down. Remove the rear panel first and use a voltmeter on the high voltage scale to determine that there is no voltage

between the red anode and blue cathode conductors. Look for these wires on the terminal block fastened to the inside surface of the rear panel.

The front window and rear panel of the flashhead are secured by eight (8) quarter-turn captive fasteners. These can be rotated for tightening or removal with a medium, flat-blade screwdriver.

Mounting

Power Converter

Figure 2-2 shows the mounting and clearance dimensions for the power converter. Three receiving holes in the base allow insertion of 2-inch threaded mounting pipes secured by conduit locking nuts. FTCA does not provide the pipes and locking nuts.

Flashhead

Figure 2-3 shows mounting and clearance dimensions for the flashhead. The flashhead yoke has a mounting hole for 2-inch threaded pipe. FTCA does not provide the pipe and fittings.

Leveling

The flashhead may be leveled by using the leveling vial provided on the yoke. It may be tilted to achieve the desired vertical beam alignment.

Installation

Figure 2-1 shows a typical system configuration. This manual may not contain all the information about installation wiring required for your installation.

Note: If installation drawings prepared specifically for your site disagree with information provided in this manual, the site installation drawings should take precedence. Consult any site-specific installation wiring diagram supplied with your equipment.

Note: FTCA wiring diagrams define only minimum requirements recommended for satisfactory operation. **It is the responsibility of the installer to comply with all applicable electrical codes.**

You can find conduit and other distribution wiring details on electrical installation diagrams provided by FTCA or others.

All installation wiring should have an insulation rating of 600 volts. Size the power service wiring to satisfy the load demand of all of the power converters. Read the notes on the installation wiring diagrams supplied both in this manual and with the equipment.

Power Converter Wiring

Consult the installation wiring diagrams. For service wiring, consider the voltage, length of the wire run, and the total load (number of lights). Assume a load of 1000 VA per light.

The power converter case must be grounded to the site grounding system. A grounding lug is provided on the base of each power converter.

Flashhead Wiring

The power converter and flashhead are interconnected by the flashhead cable. When FTCA flashhead cable Part Number 4336000 is used, the two may be separate by a distance of up to 150 feet. Consult the factory when a greater separation is necessary. The cable requires seven conductors with 600 volts (minimum)

insulation. Two of the conductors must be #10 AWG. The other five may be #14 AWG (minimum; for mechanical strength) if you are cabling together individual wires.

To ensure long-term reliability, use continuous cable between the power converter and flashhead without intervening junctions or splices.

Securing the Cable

FTCA recommends the following procedure for securing the flashhead cable to a skeletal structure:

1. Wrap two full turns of two-inch Scotchrap #50 tape, or equivalent alternative, around the cables and tower member at regular intervals along one of the tower legs.
2. Wrap three full turns of one-inch Scotchrap Filament #890 tape, or equivalent alternative, over the Scotchrap #50 tape.
3. Wrap four full turns of two-inch Scotchrap #50 tape, or equivalent alternative, over the Filament #890 tape. Apply the last two turns without tension.
4. In steps 1 through 3 wrap the tape directly above and below tower leg flanges, and at intervals of approximately five feet.

Installation Checklist

Complete the following steps before applying power:

1. **Equipment Damage:**
Inspect all equipment for damage.
2. **Required Equipment:**
Verify the received equipment against the packing list to ensure completeness.
3. **Power Converter Wiring:**
Examine the installation drawings and use the following guidelines:
 - Check for proper incoming service voltage.
 - Wire each unit according to the instructions.

- Check all electrical connections for tightness.
- Check all terminal strip connections for tightness.
- Ground the power converter to the site grounding system.

4. Power Converter Mounting:

Position and mount each unit allowing adequate clearance for opening the covers.

Also, use the following guidelines:

- Ensure that the case is mounted upright and grounded to the site grounding system.
- Check hardware inside the case to ensure that the chassis mounting screws and nuts are tight.
- Ensure that only the bottom of the case has drain holes and that they are clear.
- Ensure that no holes are punched or drilled on the top surface of the case.

- Ensure that air can flow around the case.
- Mount the power converter away from radio frequency interference (RFI).

5. Flashhead Mounting:

Level and aim the flashhead.

6. Flashhead Wiring:

- If the flashhead is elevated, protect the flashhead against lightning strikes.
- Ground the flashhead to the site grounding system.
- Check the wiring of the flashhead cable to the flashhead.
- If mounted on a tower, secure the flashhead cable to the tower. Support and tape the cable to prevent its movement by the wind.

After completing all the steps listed above, turn on the power converter and perform an operational checkout.

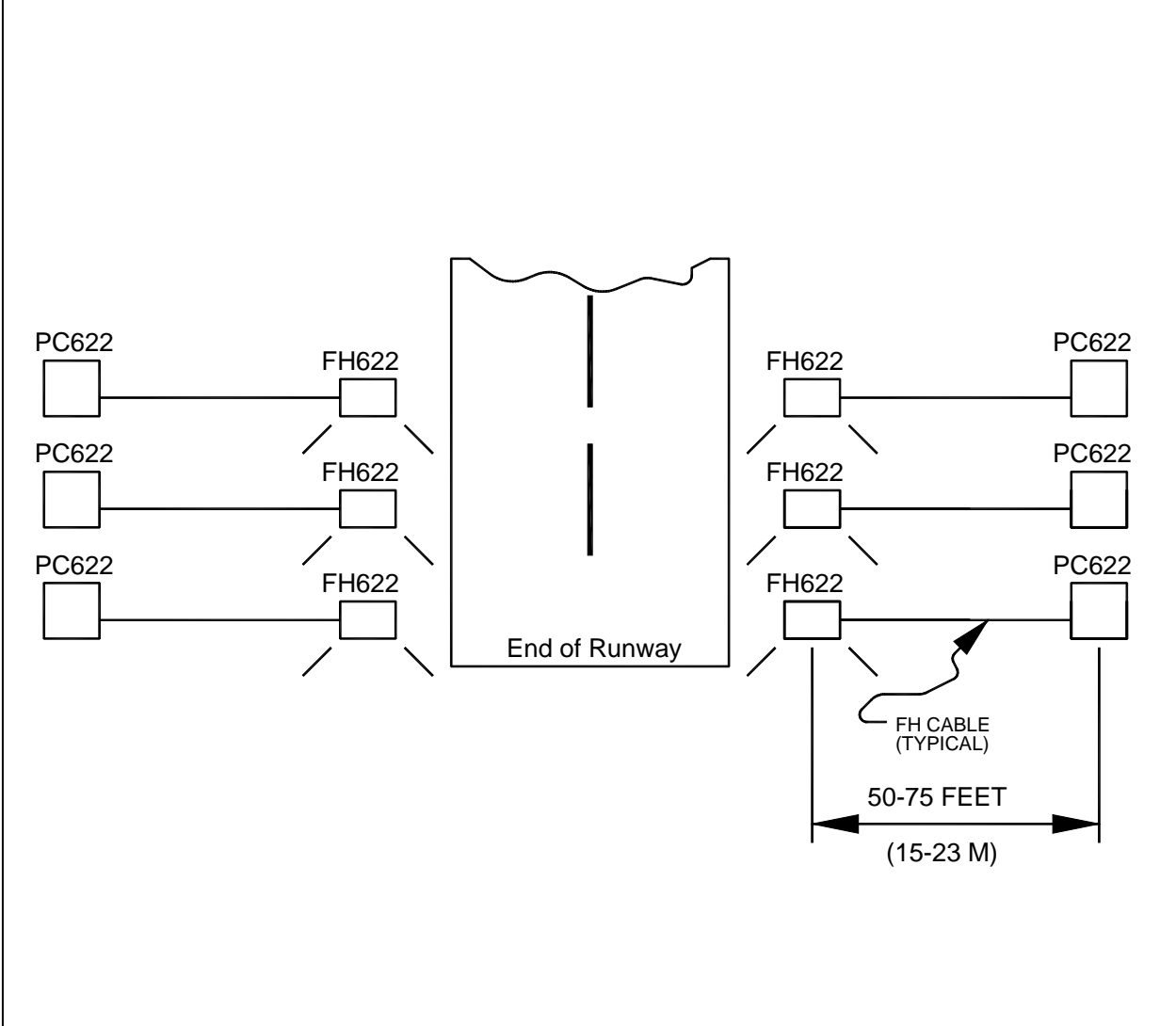

Figure 2-1 Typical System Configuration

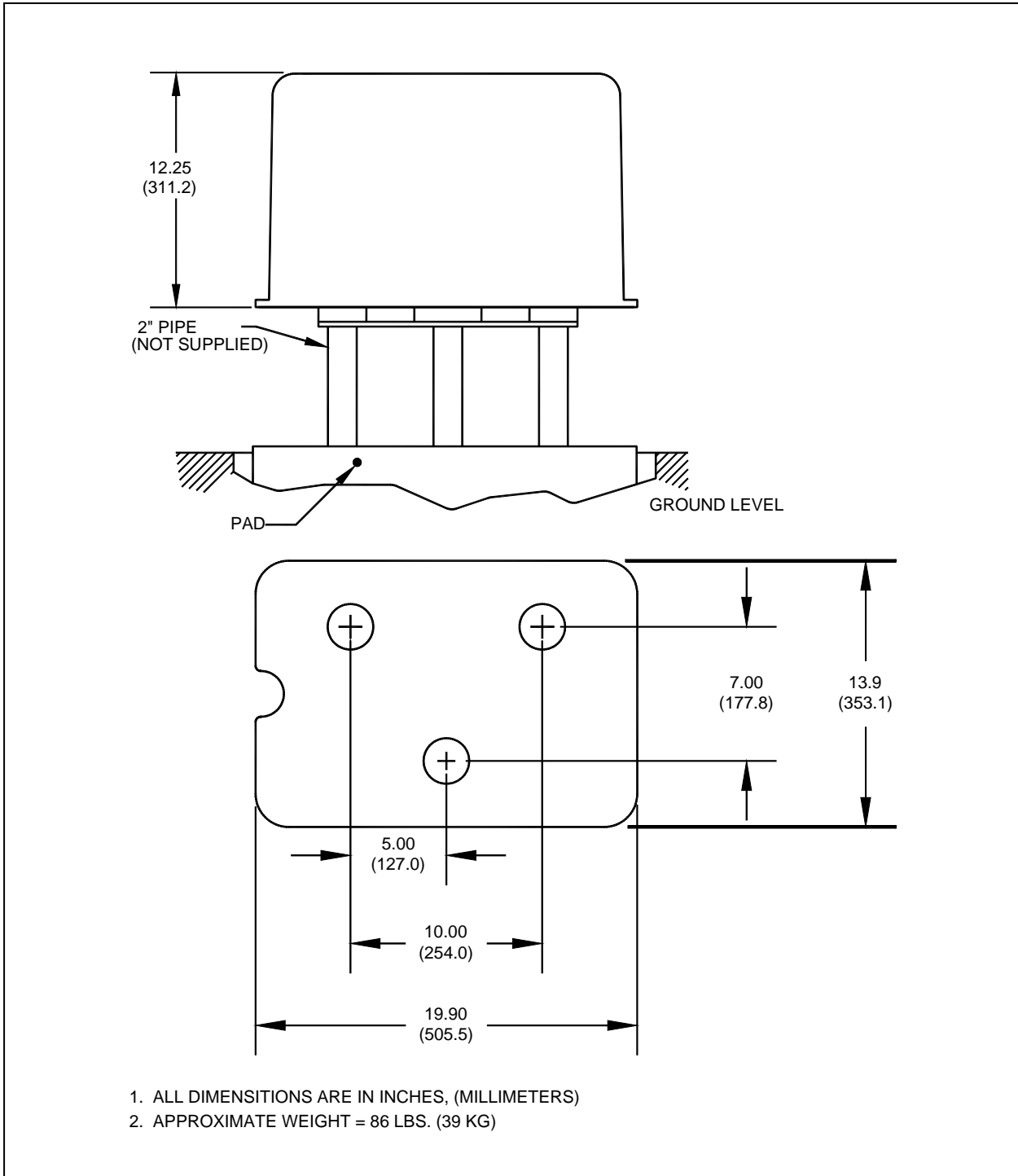

Figure 2-2 Power Converter Mounting and Outline

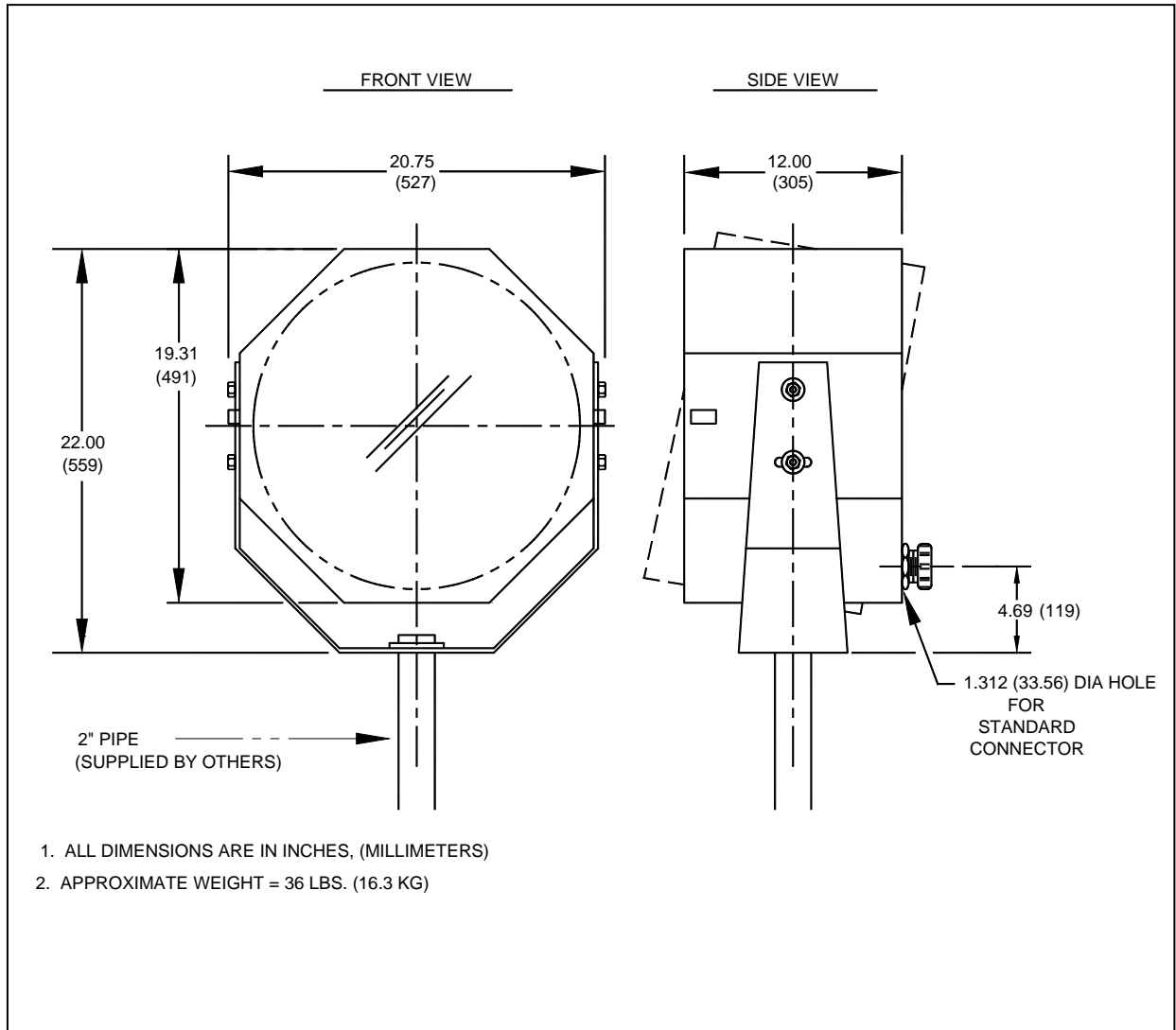

Figure 2-3 Flashhead Mounting and Outline

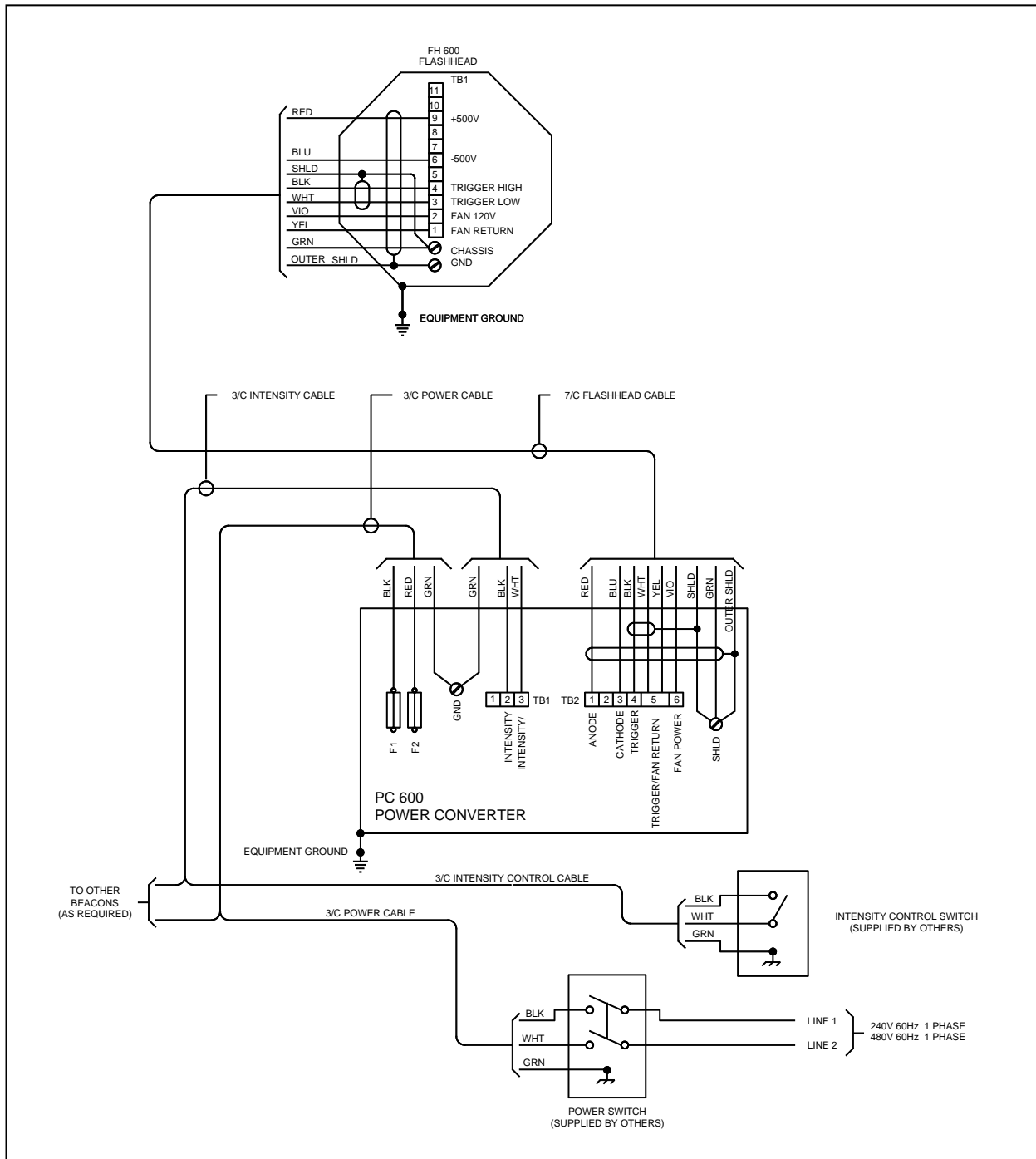

Figure 2-4 Typical Installation Wiring

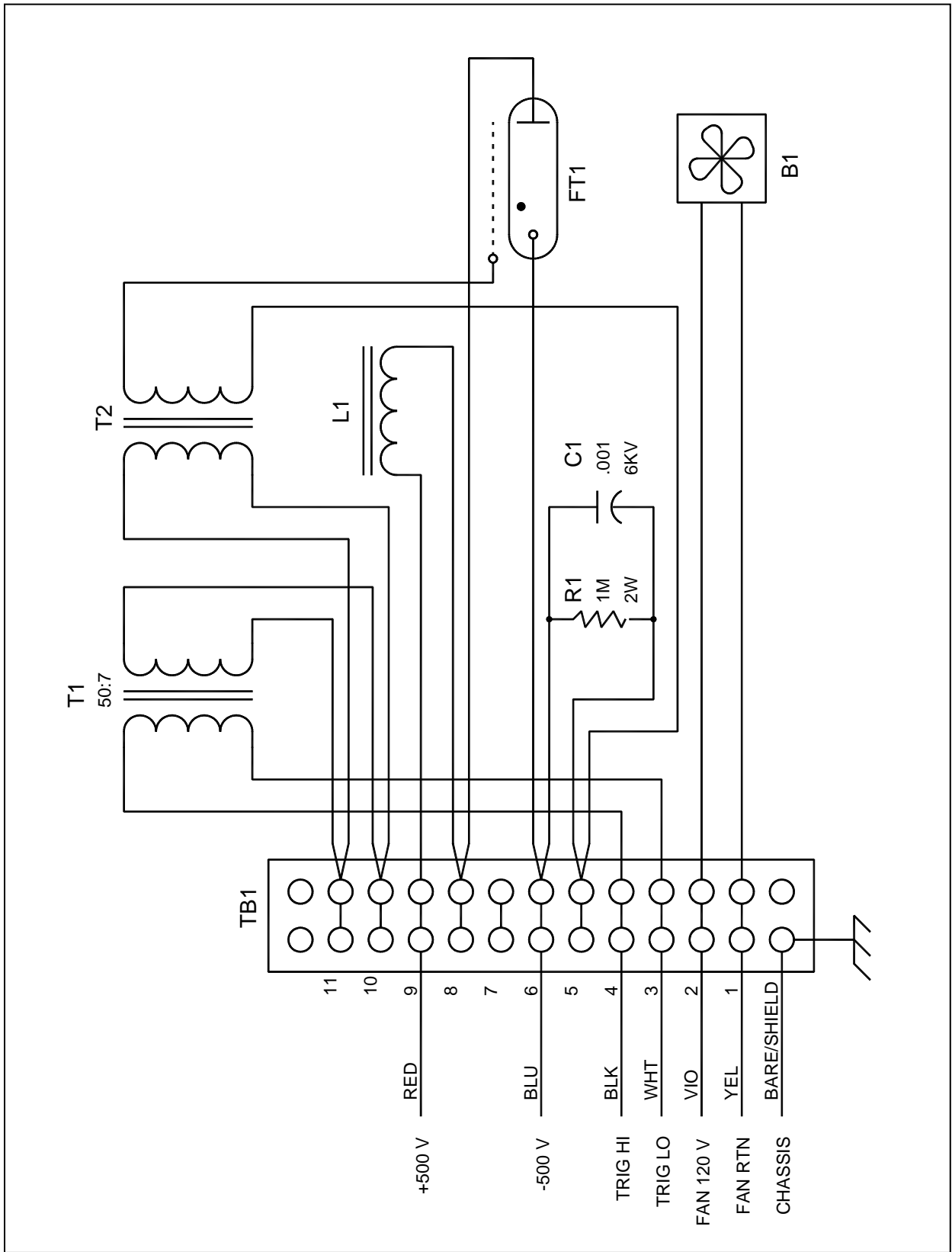

Figure 2-6 Flash head Internal Wiring

Section 3 – Maintenance and Troubleshooting

Safety

WARNING

STOP: Before proceeding—read the warning on Page iii.

Work safely, as follows:

1. Remove rings and watches before opening the equipment.
2. Shut off the equipment.
3. Remove the component or connect the test instruments.
4. Replace the component.
5. Turn on the power and test the system.
6. Turn off the power and disconnect the test equipment.

Preventive Maintenance

Carry out the following inspection and cleaning procedures at least once a year:

1. Verify that moisture has not accidentally entered the equipment through gaskets or seals, or collected inside as condensation.
2. Verify that all drain holes are clear.
3. Check terminal blocks and relays for corrosion or arcing. Clean or replace any component that shows evidence of high-voltage damage.
4. Check flashtube connections for signs of pitting or arcing. Verify that anode and cathode connections are firmly tightened.
5. Check all electrical connections for tightness and verify the absence of corrosion or electrical arcing.
6. Clean the outside surface of the lens with liquid detergent and water. Wipe it gently with a soft cloth or paper towel.
7. Clean the reflecting surface of the reflector with a liquid detergent and water. Wipe it gently with a soft cloth.

Storage

Long-term storage of the equipment requires no special considerations.

RFI Problems

The presence of radio frequency interference (RFI) can burn out components, cause a light to flash intermittently, at the wrong rate, or at the wrong intensity. RFI can enter the light by any wire to or from the unit. The circuits reject or bypass RFI, but FTCA cannot guarantee complete immunity beforehand. After installation, you may find it necessary to add external filters or use other methods to reduce RFI entering the equipment.

Component Testing

The following procedures describe how to check most of the unit's major electrical components. Always make resistance measurements with the primary power turned off. However, you must make voltage measurements with power applied. Thus, for your safety, carry out all preliminary steps such as connecting test leads or circuit jumpers, or disconnecting existing circuit connections with the power off.

Capacitors

Evaluate the condition of a capacitor with an analog volt-ohmmeter operating in the resistance mode. The following method assumes an instrument with a X100 resistance scale.

Place the meter leads across the terminals of an isolated (no electrical connections to other circuits) and fully discharged capacitor. Observe the subsequent needle movement.

If the capacitor is functional, the needle initially indicates zero ohms, but soon begins to rise to higher indicated values. A capacitor that is disconnected from other circuitry is defective if it does not exhibit this behavior. The length of time it takes the needle to reach the 1-megohm reading (about 65% full-scale) is a measure of the capacitance. For example, the time is about 5 seconds for a 10-mfd. capacitor, or 10 seconds for a 20-mfd. capacitor, and so forth.

Manually discharge the capacitor before repeating this measurement. This test may not detect a malfunction that occurs only at high voltage.

A bank of capacitors connected in parallel may be checked as a single unit. If the test indicates a short circuit, the individual capacitors have to be disconnected and checked separately. A shorted capacitor is indicated if the resistance does not rise above zero after several seconds of measurement.

Wiring and Cabling

Wires or cables that move repeatedly will ultimately break. Ensure that all cables (the flashhead cable in particular) are securely fastened at short intervals to the structure or other supports.

Inspection

Units

Closely inspect the units and check the connections against the installation instructions. A close inspection may reveal insulation breakdown, overheated components, corrosion, loose connections, faulty relays, incorrect hookup, and so forth.

Relays

A malfunctioning relay may have faulty

contacts, a sticky mechanism, or a defective coil. You may determine the first two possibilities by inspection and manually exercising the armature. You can confirm a defective coil by measuring the resistance.

Power Converter

Relays (K2, K3)

To measure the resistance of relay coils, first remove the wires from one of the connections to the coil terminals on the relay. The coil of Mode Relay K2 should have a resistance of approximately 290 ohms. The coil of Discharge Relay K3 should have a resistance of approximately 290 ohms.

Timing and Trigger Board (PCB1)

Replace this circuit board with one known to be in good condition.

HV Rectifier Boards (PCB2A, PCB2B, PCB2C)

Replace this circuit board with one known to be in good condition.

Trigger Coupling Transformer (T3)

The coupling transformer should not have open windings. An ohmmeter will indicate a shorted winding because of the wire size. Check with an ohmmeter at the wire terminals. Check the ferrite core for cracks.

Discharge Resistors (R1A and R1B)

Their resistance between ceramic posts P1 and P2 should be 17,500 ohms. Disconnect harness wires before making a measurement. Power Transformers (T1A, T1B, T1C) To test any of these transformers, first remove the PCB1 and the HV rectifier boards (PCB2A, PCB2B, and PCB2C). Apply power to the unit and measure secondary winding voltages at the terminals indicated in *Table 3-1*.

Table 3-1 Power Transformer Voltages

Terminals	Voltage Range Allowed
5 to 7	1030 – 1060 VAC ¹
8 to 9	100 – 120 VAC
10 to 11	22 – 26 VAC

1. If this AC voltage is substantially below the specified minimum value, check the C4 tuning capacitor.

Flashhead

Flashtube

Visually inspect the flashtube for broken electrodes, cracked glass, and the solder connections of the pins. A darkened envelope does not necessarily mean the light output would be unacceptable. Before concluding that a faulty flashtube is responsible for an inadequate flash, first rule out other possible causes such as weak or absent discharge voltage or triggering pulses.

Trigger Transformer (T101)

The measured resistance of the secondary winding (potted assembly) should be 156 ohms \pm 4 ohms. Check the ferrite core for cracks. Check the mounting screws for tightness.

Component Removal and Replacement

A power converter component location diagram is provided in *Figure 4-1*. A flashhead component location diagram is provided in *Figure 4-2*. A flashhead electrical wiring diagram is provided in *Figure 2-6*. A power converter internal wiring diagram is provided in *Figure 2-5*.

Power Converter Components

Capacitors

Before removing or replacing a capacitor always ensure it is discharged by checking

with a voltmeter directly across the terminals. Discharge a capacitor by placing a resistance (25 watts/10,000 ohms or greater) between its terminals. Direct shorting may damage the capacitor, and connecting the terminals to the equipment chassis may fail to discharge it.

Remove the fuse for this procedure to prevent application of power if the interlock switch is accidentally pressed.

Removal

1. Disconnect the wires leading to capacitors.
2. Remove the hold-down screws.
3. Lift the capacitors from their receiving holes.

Replacement

1. Reverse the removal procedure.
2. Verify that wiring is in accordance with the wiring diagram in *Figure 2-5*. Wires must be replaced exactly as removed. In some instances, a quick-connect wire terminal does not seat properly if it is not placed on the terminal cluster exactly as it was before removal. This occurs by interference between the insulation on the wire terminal and the insulation surrounding their terminal cluster on the capacitor.

FTCA recommends that you lightly squeeze the quick-connect wire terminals with pliers before reinstalling them over the capacitor terminal blades.

Timing and Trigger Board (PCB1)

Removal

1. Loosen all attaching screws from the PCB1 terminal block.
2. Loosen (but do not remove) the screws located near the corners of the board that hold the board to the chassis.
3. Slide the board out from the screws and lift the board.

Replacement

Reverse the removal procedure.

Power Transformers (T1A, T1B, T1C)

Removal

1. Disconnect the harness wires from the transformer. Take note of the connections so as to replace the wires correctly.
2. Remove the four 1/4-20 screws holding the transformer to the base plate and remove the transformer.

Replacement

1. Reverse the removal procedure.
2. Verify that wiring agrees with *Figure 2-5* and restore the wire routing to its original position.

HV Rectifier Board (PCB2A, PCB2B, PCB2C)

Removal

1. Loosen, but do not remove, the screws holding PCB2 to the terminal block.
2. Slide the circuit board out from under the terminal block screws.

Replacement

1. Reverse the removal procedure.
2. Restore the wire routing to its original state.

Mode Relay (K2), Discharge Relay (K3)

Removal

1. Disconnect the harness from the capacitors and other components residing on the component bracket that spans over the base plate.
2. Remove the screws that fasten the component bracket to the base plate.
3. Carefully lift off the component bracket and support it so that you may access the relays.
4. Loosen the screws that fasten the wiring connectors to the relay.

5. Carefully disconnect the wires from the terminals of the relay and note their locations so that you may more easily replace them.
6. Remove the screws that hold the relay to the base plate.
7. Remove the relay.

Replacement

1. Reverse the removal procedure.
2. Verify that wiring agrees with *Figure 2-5* and restore the wire routing to its original state.

Flashhead Components

Flashtube (FT101)

Removal

1. Remove the glass window and filter secured by eight (8) quarter-turn captive fasteners.
2. Loosen the three screws (on screw lugs). This enables you to free the pins on the base of the flashtube.
3. Carefully lift the flashtube upward from the assembly.

Replacement

1. Align the pins on the flashtube base with the clamps of the terminal screw lugs, making sure that the red dot on the flashtube base coincides with the red dot marked on the bracket directly under it.
2. Carefully insert the flashtube and settle it into place, making sure the ceramic base is resting directly on the tops of the screw lugs.
3. Secure the flashtube by tightening the three screws on the screw lugs.
4. Replace the filter and the glass window, and secure both with the eight (8) quarter-turn captive fasteners.

Trigger Transformer (T101)

Removal

1. Remove the glass window and filter, which are secured by eight (8) quarter-turn fasteners.
2. Remove the reflector assembly secured by four Phillips-head screws and four elastic stop-nuts.
3. Remove the flashtube and disconnect the large white conductor at one of the flashtube support insulators.
4. Pull the large white conductor out through the cooling fan shroud assembly.
5. Disconnect the small wire from the trigger transformer's potted coil where it is attached to the flashhead terminal block.
6. Remove the two 4-40 x 2" Phillips-head screws holding the transformer assembly to the bracket. Note the orientation of the molded secondary winding with respect to fixed features on the bracket, because it must be installed with the same orientation.
7. Remove the outer half of the core and lift off the molded secondary winding. The seven turns of the primary winding will remain hanging in place.
8. Remove the inner half of the core, taking care not to uncoil any turns of the primary winding.

Replacement

Reverse the removal procedure.

Trigger Coupling Transformer (T102)

Removal and replacement are similar to the procedure for the Trigger Transformer (T101).

Operational Checkout

Visually check the flashing lights. They should all be flashing together with the same intensity. If an optional intensity switch is available, check also the nighttime intensity.

Intensity

Daylight intensity is very bright and nighttime intensity is noticeably reduced.

PCB1 Indicator Lamps

Table 3-2 PCB1 Indicators

LED / Lamp Indicator	LED / Lamp Function Description
I1	SYNC LED – Blinks at the flash rate.
Neon	Trigger Power – Indicates that 120 VAC trigger voltage is available.

Troubleshooting

The most effective diagnostic and troubleshooting procedure is observing the operation of the unit. This often leads directly to the identification of a faulty component or other abnormal condition. As shown in *Table 3-3*, for a unit that is not flashing properly (or at all), notice three important behaviors: the flash itself (weak, erratic, or absent); the high and low voltages (HV and LV — see the footnotes in *Table 3-3*). These behaviors combine in various ways to yield five different symptoms, A through E, as shown in the table. If the flash is normal, the diagnostics in this table do not apply.

Table 3-4 correlates the five symptoms from *Table 3-3* with the components, assemblies, or conditions most likely to cause them. When a symptom has more than one possible cause, the various causes are weighted to indicate estimated probability.

For example, not flashing with both high voltage (HV) and low voltage (LV) normal constitute symptom "B" in *Table 3-3*. *Table 3-4* indicates: the most likely cause is FT101; the next most likely cause is PCB1; and the third most likely cause is T102.

To identify a faulty component replace it with one known to be in good condition. Some components can also be tested directly. After determining that the problem may be caused by a specific malfunctioning component, use the procedure for testing the component in Section Component Testing on Page 3-1. If the component is faulty, replace it according to the appropriate component replacement procedure in Section Component Removal and Replacement on Page 3-3.

Table 3-3 Troubleshooting Symptoms

Symptom	Observed Behavior		
	Flash	HV ¹	LV ²
A	NO	NO	NO
B	NO	OK	OK
C	NO	OK	NO
D	WEAK	OK	OK
E	ERRATIC	OK	OK

1. Neon lights out on PCB2 means high voltage (HV) is absent.
2. LED out on PCB1 means low voltage (LV) is absent.

Table 3-4 Fault Locator

Possible Problem Component	Symptoms from Table 3-3				
	A	B	C	D	E
F1, F2	1				
F3A, F3B or F4			2	1	
F3C				1	
FT 101		1			1
K2				5	
PCB2 (A, B and/or C)				2	
PCB 1		2		4	
S1	2				
T1 (A, B and/or C)			1	3	
T102		3			2

This page is intentionally left blank.

Section 4 – Replaceable and Spare Parts

Customer Service

Customer Service 1-800-821-5825
FTCA Telephone: (615) 261-2000
Facsimile: (615) 261-2600

Shipping Address:

Flash Technology Corporation of
America
332 Nichol Mill Lane
Franklin, TN 37067

Ordering Parts

To order spare or replacement parts, contact FTCA customer service at 1-800-821-5825.

Power Converter Parts

Table 4-1 lists the major replaceable parts for the power converter.

Flashhead Parts

Table 4-2 lists the part numbers for the major replaceable parts

Returning Equipment

Call FTCA Customer Service at 1-800-821-5825 for a Return Material Authorization (RMA) number before returning equipment.

Repackaging

Return equipment in a container that provides maximum protection. If the original cartons and packaging material are no longer available, package the power converter and flashhead separately as follows:

Power Converter

Package and ship the power converter in an upright position; that is, with the baseplate downward. Pad the power converter so that the base or corners cannot penetrate the box during shipment. Box each power converter separately using a double thickness cardboard container and adequate padding. Do not drop. Use appropriate warning labels on the outside of the container.

Flashhead

Package and ship the flashhead in an upright position. Box each flashhead separately and use adequate padding to protect the top, bottom, and edges. Attach the flashhead base to a 3/8 inch plywood plate. Use a double thickness cardboard (or wood) container. Do not drop. Use appropriate warning labels on the outside of the container.

Table 4-1 Power Converter Major Replaceable Parts

Item	Description	Part Number
C1A-C1H, C1J, C2A, C2B	Capacitor, 70 mfd	6720401
C4A, C4B, C4C	Capacitor, 3 mfd	6577903
F1, F2	Fuse, Main, 15 Amp	4900327†
F3A, F3B, F3C	Fuse, Branch Circuits, 8 Amp	4900335†
F4	Fuse, Fan, 1 Amp	4900337†
K2	Relay, Mode, 24 V	8900494†
K3	Relay, Discharge, 120 V	8900493†
L2	Choke, Flash	4175200
PCB1	Timing and Trigger Board	2589701†
PCB2A, PCB2B, PCB2C	High Voltage Rectifier Boards	2458006†
R1A, R1B	Resistors, Discharge, 35K 50W	6900541
S1	Switch, Interlock	8205501
T1A, T1B, T1C	Power Transformer	8841504
T3	Coupling transformer	8336701
TB1, TB5	Terminal Strip, 3 Position	8721003
TB2	Terminal Strip, 6 Position	8721006
TB3, TB4A, TB4B, TB4C	Terminal Strip, 11 Position	8721011
VR1	Suppressor	8250804†*

†Recommended as a spare part.

*This part number varies according to the specific equipment voltage configuration.

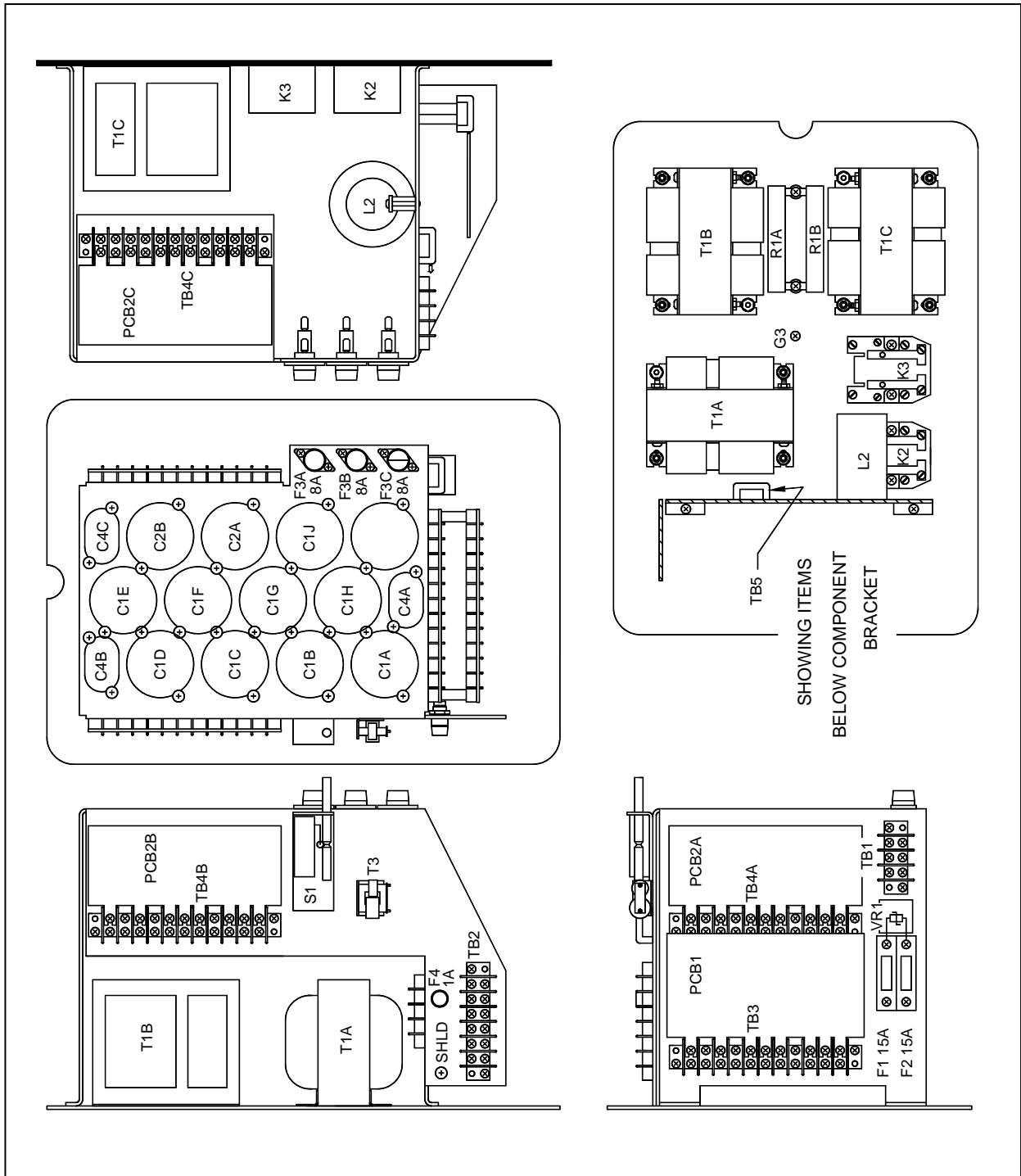

Table 4-2 Flashhead Major Replaceable Parts

Item	Description	Part Number
CF 101	Fan, cooling	4642200
FT 101	Flashtube	8384306†
Lens	Clear	3622502
	Red	3631401
Post	Insulator	4900476
RC 101	Resistor-Capacitor Network	1403411
T 101	Trigger Transformer	8288201
T 102	Transformer, Coupling	8336701
TB101	Terminal strip	8721011

† Recommended as a spare part.

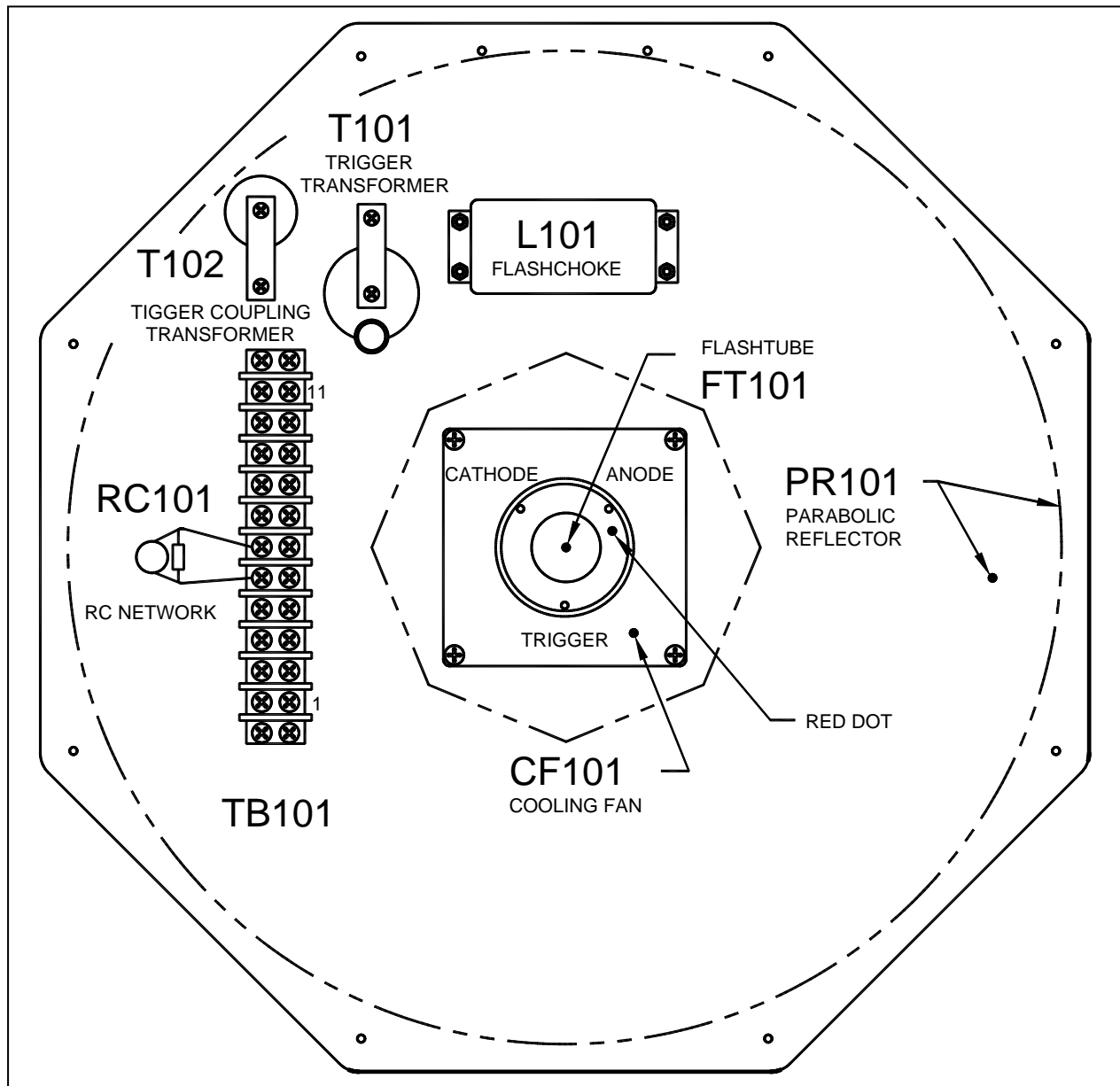

Figure 4-2 Flashhead Component Layout

RETURN MATERIAL AUTHORIZATION (RMA) POLICY

IF A PRODUCT PURCHASED FROM FLASH TECHNOLOGY MUST BE RETURNED FOR ANY REASON (SUBJECT TO THE WARRANTY POLICY), PLEASE FOLLOW THE PROCEDURE BELOW:

Note: An RMA number must be requested from Flash Technology prior to shipment of any product. No returned product will be processed without an RMA number. This number will be the only reference necessary for returning and getting information on the product's progress.

Failure to follow the below procedure may result in additional charges and delays. Avoid unnecessary screening and evaluation charges by contacting Technical Support prior to returning material.

1. To initiate an RMA, customers should call Flash Technology's National Operations Center (NOC) at (800-821-5825) to receive technical assistance and a Service Notification number. The following information is required before a Service Notification number can be generated:

- Site Name/Number / FCC Registration number/ Call Letters or Airport Designator
- Site Owner (provide all that apply – owner, agent or subcontractor)
 - Contractor Name
 - Contractor Company
- Point of Contact Information: Name, Phone Number, Email Address, Fax Number and Cell Phone (or alternate phone number)
- Product's Serial Number
- Product's Model Number or part number
- Service Notification Number (if previously given)
- Reason for call, with a full description of the reported issue

2. The Service Notification number will then serve as a precursor to receiving an RMA number if it is determined that the product or equipment should be returned. To expedite the RMA process please provide:

- Return shipping method
- Purchase Order (if non-warranty repair)
- Shipping Address
- Bill To Address
- Any additional information to assist in resolving the issue or problem

3. A P.O. is required in advance for the replacement of product that may be under warranty. Flash will then, at its discretion issue a credit once the validity of the warranty has been determined.

4. A purchase order (P.O.) is also required in advance for all non-warranty repairs. NOTE: the purchase order is required prior to the issuance of the RMA number.

- If the P.O. number is available at the time of the call, an RMA number will be issued and the customer must then fax or email the P.O. with the RMA number as the reference, to ensure prompt processing.
- If the P.O. number is NOT available at the time of the call, a Service Notification Number will be given to the customer and should be referenced on the P.O. when faxed or emailed to RMA Rep.
- Flash will then, at its discretion repair or replace the defective product and return the product to the customer based on the shipping method selected.
- The customer may purchase a new product before sending in the existing product for repair. If Flash Technology determines the existing product is still covered under warranty a credit will be issued to the customer for the new product.

5. After receiving the Flash Technology RMA number, please adhere to the following packaging guidelines:

- All returned products should be packaged in a way to prevent damage in transit. Adequate packing should be provided taking into account the method of shipment.

Note: Flash Technology will not be responsible for damaged items if product is not returned in appropriate packaging.

6. All packages should clearly display the RMA number on the outside of all RMA shipping containers. RMA products (exact items and quantity) should be returned to:

Flash Technology
Attn: RMA #XXX
332 Nichol Mill Lane
Franklin, TN 37067

7. All RMA numbers:

- Are valid for 30 days. Products received after may result in extra screening and delays.
- Must have all required information provided before an RMA number is assigned.

RETURN TO STOCK POLICY

- **Parts can be returned within 60 days of ship date and will be subject to a 25% restocking fee. Product must:**
 - Be in the original packaging
 - Not be damaged
- **After 60 days no parts can be returned**