

# FLASH TECHNOLOGY



## Vanguard® Red FTS 371 SMART

Medium Intensity Red LED Obstruction Lighting System

---

Reference Manual

Part Number F7913800

Flash Technology, 332 Nichol Mill Lane, Franklin, TN 37067

[flashtechnology.com](http://flashtechnology.com)

1.615.503.2000 | 1.800.821.5825

## FRONT MATTER

### ABSTRACT

This manual contains information and instructions for installing, operating and maintaining the Vanguard Red FTS 371 SMART system components.

### COPYRIGHT

©2021, Flash Technology, LLC. All rights reserved.

Reproduction or use of any portion of this manual is prohibited without express written permission from Flash Technology and/or its licensor.

### TRADEMARK ACKNOWLEDGEMENTS

Flash Technology® and Vanguard® are registered trademarks of SPX Corporation.

All trademarks and product names mentioned are properties of their respective companies, and are recognized and acknowledged as such by Flash Technology.

### APPLICABLE SPECIFICATIONS

The equipment included in this system meets or exceeds FAA AC 150/5345-43J requirements for the FAA Type L-864, L-885, L-810 and L-810(F) obstruction lights. This equipment can accommodate system configurations that meet the FAA AC/7460-1M, FAA AC/7460-1L and FAA AC/7460-1K standards for marker configurations.

The equipment included in this system meets or exceeds requirements for Transport Canada CAR621.19 types CL-864, CL-885, and CL-810.

The equipment included in this system meets or exceeds requirements for ICAO Annex 14 Sixth Edition for Medium-intensity obstacle lights Types B and C, as well as Low-intensity obstacle light Type B.

### DISCLAIMER

While every effort has been made to ensure that the information in this manual is complete, accurate and up-to-date, Flash Technology assumes no liability for damages resulting from any errors or omissions in this manual, or from the use of the information contained herein. Flash Technology reserves the right to revise this manual without obligation to notify any person or organization of the revision.

In no event will Flash Technology be liable for direct, indirect, special, incidental or consequential damages arising out of the use of or the inability to use this manual.

### WARRANTY

Under normal operating conditions, Flash Technology warrants all controller and LED lighting components for 5 years.

### PARTS REPLACEMENT

The use of parts or components in this equipment that are not manufactured or supplied by Flash Technology voids the warranty and invalidates the third party testing laboratory certification which ensures compliance with FAA Advisory Circulars 150/5345-43J, 150/5345-53D and Engineering Brief No. 67D. The certification is valid as long as the system is maintained in accordance with FAA guidelines (FR doc. 04-13718 filed 6-16-04).

## PERSONNEL HAZARD WARNING

---

### DANGEROUS VOLTAGES

Dangerous line voltages reside in certain locations in this equipment. Also, this equipment may generate dangerous voltages. Although Flash Technology has incorporated every practical safety precaution, exercise extreme caution at all times when you expose circuits and components, and when you operate, maintain or service this equipment.

---

### AVOID TOUCHING LIVE CIRCUITS

Avoid touching any component or any part of the circuitry while the equipment is operating. Do not change components or make adjustments inside the equipment with power on.

---

### DO NOT DEPEND ON INTERLOCKS

Never depend on interlocks alone to remove unsafe voltages. Always check circuits with a voltmeter after turning the circuit breakers off. Under no circumstances remove or alter the wiring or interlock switches.

## TABLE OF CONTENTS

Front Matter .....	2
Abstract .....	2
Copyright .....	2
Trademark Acknowledgements .....	2
Applicable Specifications .....	2
Disclaimer .....	2
Warranty .....	2
Parts Replacement .....	2
Personnel Hazard Warning .....	3
List of Figures .....	6
List of Tables .....	6
Section 1 – Introduction and Specifications.....	8
Regulatory Compliance and Certifications .....	8
System Specifications.....	9
Controller: FTS 371 FTC SMART AC, FTS 371 FTC SMART DC, FTS 371 FTS SMART DC (-) 24/48V .....	9
Flashhead/Beacon: FTS 371 FH AC, FTS 371 FH DC 24V, FTS 371 FH DC 48V .....	9
Markers: MKR 371 / MKR 372 IR Series .....	10
Markers: MKR 371 OL2 / MKR 372 IR OL2 Series.....	10
Section 2 – Outline, Mounting and Installation Instructions .....	11
Unpacking.....	11
Tools.....	11
Controller Installation and Grounding.....	11
L-864 Flashhead/Beacon Installation and Grounding .....	12
OL2 Installation and Wiring for A0 Towers .....	12
Marker Installation and Wiring .....	13
Lightning Protection.....	13
System Wiring.....	13
Securing the Cable (2-3-4 Tape Method).....	14
AM “Hot” Tower Wiring .....	14
Flashhead/Beacon Wiring.....	14
Controller Wiring .....	15
Input power connections .....	15

# FTS 371 SMART USER MANUAL

Beacon and Marker Connections .....	15
Dry Contact Monitoring and Photodiode Connections .....	16
Radar and Primary/Secondary Connections .....	16
Catenary Operation.....	17
GPS Synchronization .....	17
RS-485 Modbus RTU Communication .....	18
Installation Checklists.....	19
Checkout Procedure.....	19
Section 3 – Maintenance Instructions .....	38
Safety.....	38
Maintenance.....	38
Troubleshooting.....	38
Component Removal and Replacement.....	38
FTS 371 FTC SMART Controller .....	38
FTS 371 FH AC (L-864 LED).....	39
Firmware Upgrades.....	39
Preparing the USB Drive.....	39
Upgrading Firmware .....	39
Downgrading Firmware.....	40
Additional Notes .....	40
Section 4 - Operating Instructions.....	41
Controller.....	41
Manual Override Option.....	41
Tower Configurations.....	41
Controller Configuration Switch Definitions .....	41
Marker # Configuration Switch .....	42
Alarm Indicators.....	42
Flashhead/Beacon LED Indicators.....	44
Flashhead/Beacon Switch Bank .....	44
Flashhead/Beacon Switch Definitions .....	44
Major Troubleshooting Symptoms.....	45
Section 5 – Customer Support .....	46
Contact Information.....	46
Ordering Parts.....	46

# FTS 371 SMART USER MANUAL

RMA Policy.....	46
-----------------	----

## LIST OF FIGURES

Figure 1 – Controller FTS 371 SMART Poly Enclosure Mounting and Outline .....	22
Figure 2 – Controller FTS 371 SMART Aluminum Enclosure Mounting and Outline.....	23
Figure 3 – Marker MKR 371 / MKR 372 IR series mounting and outline view .....	24
Figure 4 – OL2 mounting and outline view .....	25
Figure 5 – Flashhead/Beacon FTS 371 FH mounting and outline view .....	26
Figure 6 – Photodiode PHD 516 mounting and outline view .....	27
Figure 7 – Controller FTS 371 FTC SMART AC Connection Diagram .....	28
Figure 8 – Flashhead/Beacon FTS 371 FH AC Connection Diagram .....	29
Figure 9 – FTS 371 SMART AC Typical FAA Type A0 Installation Wiring .....	30
Figure 10 – FTS 371 SMART AC Typical FAA Type A1 Installation Wiring.....	31
Figure 11 – FTS 371 Typical A1 Tower View.....	32
Figure 12 – Controller FTS 371 SMART DC Connection Diagram.....	33
Figure 13 – Controller FTS 371 SMART DC (-) Connection Diagram .....	34
Figure 14 – Flashhead/Beacon FTS 371 FH DC Connection Diagram.....	35
Figure 15 – FTS 371 SMART DC Typical FAA Type A0 Installation Wiring .....	36
Figure 16 – FTS 371 SMART DC Typical FAA Type A1 Installation Wiring .....	37

## LIST OF TABLES

Table 1.1 – System and Component Model Combinations.....	8
Table 1.2 – Controller Specifications .....	9
Table 1.3 – Beacon Specifications .....	9
Table 1.4 – Single Marker Specifications .....	10
Table 1.5 – OL2 Marker Specifications .....	10
Table 2.1 – 2-3-4 Tape Method.....	14
Table 2.2 – System Installation Checklist.....	19
Table 2.3 – Before Applying Power Checklist.....	19
Table 4.1 – Controller Configuration Switch Definitions.....	41
Table 4.2 – Alarms Indicator Names and Descriptions .....	42
Table 4.3 – Beacon LED Indicators Descriptions.....	44
Table 4.4 – Beacon Switch Position Descriptions .....	44

# FTS 371 SMART USER MANUAL

Table 4.5 – Troubleshooting Symptoms and Resolutions..... 45

Table 5.1 – Replacement Parts..... 46

## SECTION 1 – INTRODUCTION AND SPECIFICATIONS

The Vanguard® Red FTS 371 SMART is comprised of

- An FTS 371 FTC SMART (AC or DC) series controller;
- Zero to eight MKR 371 L810 / MKR 372 IR series low intensity red LED obstruction lights (Marker); and
- Zero to two FTS 371 FH (AC) or zero to one FTS 371 FH (DC 24V, DC 48V) L864 medium intensity red LED obstruction lights (FH/beacon).

System and component model combinations are provided in the table below. All models are available with a GPS option.

The FTS 371 FTC SMART AC and SMART DC Controllers may be used with incoming power having the negative leg grounded and are available in either polycarbonate or aluminum enclosure. The isolated (-) 24/48V controller may be used with incoming power having either the positive or negative leg grounded and are available only with the aluminum enclosure.

The FTS 371 SMART system is designed to meet FAA, ICAO and Transport Canada regulations and to be utilized for their corresponding valid tower lighting configurations.

**Table 1.1 – System and Component Model Combinations**

System	Controller	Beacon	Markers
<b>FTS 371 SMART AC</b>	FTS 371 FTC SMART AC	FTS 371 FH AC IR (0 to 2)	MKR 371 (0 to 8) MKR 372 IR (0 to 8)
<b>FTS 371 SMART DC 24V</b>	FTS 371 FTC SMART DC	FTS 371 FH DC 24V IR (0 to 1)	MKR 371 (0 to 8) MKR 372 IR (0 to 8)
<b>FTS 371 SMART DC 48V</b>	FTS 371 FTC SMART DC	FTS 371 FH DC 48V IR (0 to 1)	MKR 371 (0 to 8) MKR 372 IR (0 to 8)
<b>FTS 371 SMART DC (-) 24/48V</b>	FTS 371 FTC SMART DC (-) 24/48V	FTS 371 FH DC 48V IR (0 to 1)	MKR 371 (0 to 8) MKR 372 IR (0 to 8)

---

### REGULATORY COMPLIANCE AND CERTIFICATIONS

- Compliant to Federal Aviation Administration (FAA) AC 150/5345-43J
- Compliant to Canadian Aviation Regulations (CAR) Standard 621
- Compliant to International Civil Aviation Organization (ICAO) Aerodromes, Annex 14, Volume 1, Eighth Edition, dated July 2018 (Medium Intensity, Type B Obstacle Light – Red)



# FTS 371 SMART USER MANUAL

## SYSTEM SPECIFICATIONS

CONTROLLER: FTS 371 FTC SMART AC, FTS 371 FTC SMART DC, FTS 371 FTS SMART DC (-) 24/48V

**Table 1.2 – Controller Specifications**

Parameter	Specification
<b>Physical Dimensions</b>	
Polycarbonate Enclosure	10" x 8" x 6" (254 mm x 203.2mm x 155.4 mm)
Aluminum Enclosure	16.1" x 10.5" x 4.91" (408.9 mm x 266.7 mm x 124.7 mm)
<b>Weight</b>	
Polycarbonate Enclosure	5.6 lbs. (2.54 kg)
Aluminum Enclosure	9.5 lbs. (4.31 kg)
<b>Operating Temperature Range</b>	-40 to +55 degrees Celsius
<b>Input Voltage Range</b>	
FTS 371 FTC SMART AC	100 – 240VAC Nominal; 85-265 VAC at 50/60 Hz
FTS 371 FTC SMART DC	12 – 48 VDC +/- 10% (12VDC kit for marker-only {OL2} configuration)
FTS 371 FTC SMART DC (-) 24/48V	24 – 48 VDC +/- 10% (21.6 – 52.8V)
<b>Power Consumption</b>	
FTS 371 FTC SMART AC	3.8 Watts
FTS 371 FTC SMART DC	1.3 Watts
<b>Flash Rate Options (Flashes Per Minute)</b>	Steady Burn / 20 / 30 / 40 / 60
<b>Alarm Relay Contact Rating</b>	5 Amp @ 120V AC / 5 Amp @ 24V DC, Isolated contacts
<b>Protection Rating</b>	IP65, NEMA 4X

FLASHHEAD/BEACON: FTS 371 FH AC, FTS 371 FH DC 24V, FTS 371 FH DC 48V

**Table 1.3 – Beacon Specifications**

Parameter	Specification										
<b>Physical Dimensions</b>	15.75" diameter x 7.5" (400 mm diameter x 190.5 mm)										
<b>Weight</b>	25.85 lbs. (11.7 kg)										
<b>Flash Intensity</b>	FAA Mode: 2000 effective candela +/- 25% ICAO Mode: 2200 effective candela +/- 25%										
<b>Operating Temperature Range</b>	-40 to +55 degrees Celsius										
<b>Input Voltage Range</b>											
FTS 371 FH AC	85-265 VAC at 50/60 Hz										
FTS 371 FH DC 24V IR	24 +/- 10% (21.6 – 26.4V)										
FTS 371 FH DC 48V IR	48 +/- 10% (43.2 – 52.8V)										
<b>Power Consumption</b>	<table border="1"> <thead> <tr> <th>Mode</th> <th>Average Power</th> </tr> </thead> <tbody> <tr> <td>FAA, Efficient, 20 FPM</td> <td>4.0 Watts</td> </tr> <tr> <td>FAA, Efficient, 30 FPM</td> <td>5.3 Watts</td> </tr> <tr> <td>ICAO, Efficient, 20 FPM</td> <td>4.4 Watts</td> </tr> <tr> <td>ICAO, Steady</td> <td>30 Watts</td> </tr> </tbody> </table>	Mode	Average Power	FAA, Efficient, 20 FPM	4.0 Watts	FAA, Efficient, 30 FPM	5.3 Watts	ICAO, Efficient, 20 FPM	4.4 Watts	ICAO, Steady	30 Watts
Mode	Average Power										
FAA, Efficient, 20 FPM	4.0 Watts										
FAA, Efficient, 30 FPM	5.3 Watts										
ICAO, Efficient, 20 FPM	4.4 Watts										
ICAO, Steady	30 Watts										
<b>Beam Spread</b>	Horizontal: 360 deg. / Vertical: 3 deg.										
<b>Aerodynamic Wind Area</b>	99.125 in <sup>2</sup>										
<b>Protection Rating</b>	IP65, NEMA 4X										

# FTS 371 SMART USER MANUAL

MARKERS: MKR 371 / MKR 372 IR SERIES

**Table 1.4 – Single Marker Specifications**

Parameter	Specification	
<b>Physical Dimensions</b>	9.0" x 2.75" x 2.13" (228.6 x 69.9 x 54.1 mm)	
<b>Weight</b>	1.6 lbs. (0.7 kg)	
<b>Intensity (Steady)</b>	32.5 ECD +/- 25%	
<b>Operating Temperature Range</b>	-40 to +55 degrees Celsius	
<b>Power Usage</b>	Marker Type / Mode	Average Power
	MKR 371 L810 / Steady	2.5 Watts
	MKR 371 L810 / Flashing	0.4 Watts
	MKR 372 L810 IR / Steady	6.9 Watts
	MKR 372 L810 IR / Flashing	1.5 Watts
<b>Beam Spread</b>	Horizontal: 360 deg. / Vertical: 10 deg.	
<b>Aerodynamic Wind Area</b>	24.75 in <sup>2</sup>	
<b>Protection Rating</b>	IP65, NEMA 4X	

MARKERS: MKR 371 OL2 / MKR 372 IR OL2 SERIES

**Table 1.5 – OL2 Marker Specifications**

Parameter	Specification	
<b>Physical Dimensions</b>	11.25" x 5.0" x 8.75" (279.4 mm x 127 mm x 222.25 mm); ¾" NPT Coupling	
<b>Weight</b>	5.40 lbs. (2.45 kg)	
<b>Intensity (Steady)</b>	32.5 ECD +/- 25%	
<b>Operating Temperature Range</b>	-40 to +55 degrees Celsius	
<b>Power Usage</b>	Marker Type / Mode	Average Power
	MKR 371 L810 / Steady	5 Watts
	MKR 371 L810 / Flashing	0.8 Watts
	MKR 372 L810 IR / Steady	13.8 Watts
	MKR 372 L810 IR / Flashing	3 Watts
<b>Beam Spread</b>	Horizontal: 360 deg. / Vertical: 10 deg.	

## SECTION 2 – OUTLINE, MOUNTING AND INSTALLATION INSTRUCTIONS

### UNPACKING

Inspect shipping cartons for signs of damage before opening. Check package contents against the packing list and inspect each item for visible damage.

Promptly report damage claims to the freight handler.

### TOOLS

- 1/8" non-flared flat blade screw driver
- Digital volt-ohm meter
- #2 Phillips® head screwdriver
- Wire strippers
- Level
- Tin Snips
- Mounting hardware for controller (if not provided in the system kit)
- Various drill bits (to create openings in the bottom of the controller for cable runs)

### CONTROLLER INSTALLATION AND GROUNDING

Locate the FTS 371 FTC SMART controller in an area that will allow proper access to the enclosure. Ensure the mounting location does not interfere with the quick-release latch that secures the enclosure's door. Release the latch to open the door for internal access.

Use the following guidelines for mounting the controller:

- Ensure that adequate space exists around the equipment for access during installation, maintenance and servicing.
- Allow space for airflow around the controller. Recommended 3-4" of space allowed on each side of the controller. Flash Technology does not furnish mounting hardware unless it is ordered as part of an installation kit.
- Flash Technology recommends using flexible conduit for all cable runs with the exception of the beacon cable and jacketed ground wires.
- Ground the controller using a 2 AWG insulated wire. Route all ground conductors down and away from the energized equipment and ensure there are no bends less than 8 inches. If installed outdoors, bond the system controller to the site grounding grid (via exothermic welding). If installed inside a shelter or building, route the 2 AWG insulated ground wire to the nearest down-link and attach using a compression fitting (c-tap).

Use the following guidelines for installing the photodiode:

- Locate the photodiode where it has an unobstructed view of the polar sky (north).
- It must not view direct or reflected artificial light.
- Support the photodiode vertically at the top end of a vertical length of rigid conduit to prevent moisture intrusion.
- If possible, mount the photodiode in a location that will allow easy access for future testing.

## L-864 FLASHHEAD/BEACON INSTALLATION AND GROUNDING

1. Verify that the mounting surface is free of debris.
2. Align the 4 mounting holes in the base of the beacon with the holes in the tower or pedestal's mounting plate.
3. Leaving the hardware assemblies loose, secure the beacon with ½-inch stainless steel or galvanized hardware (part # 5991740).
4. With the light engine secured by the two latches on the base, place a level on the beacon's top plate and verify that it is level in 2 directions. **Note:** Flash Technology's "T"- Level (optional part # 1100013455) has 2 vials to simplify installation.
5. If the beacon is not level, add stainless steel shim material or washers (stainless steel or galvanized) as necessary to level the beacon.
6. Tighten the hardware once the beacon is level in both directions. Fully tighten the hardware and verify that the beacon is level. If necessary, loosen the mounting hardware and repeat Step 5 until the beacon is level with the hardware fully tightened.
7. Connect a minimum 8 AWG grounding wire to the pre-installed grounding lug on the beacon base exterior. Connect the other end of the wire directly to tower steel, collective buss bar or the customer's preferred location. Use an anti-corrosive agent on all terminal ends.

## OL2 INSTALLATION AND WIRING FOR A0 TOWERS

A0 towers use a double L-810 (OL2) as the beacon. Images of various OL2 styles are shown below.



There are several options in which to mount an OL2.

1. If clean steel is available with no worry of or indication of transmitting issues from other sources, a mounting bracket can be used in combination with a marker cable. Flash Technology provides a bracket (F3877103 Bracket Mounting Kit OL2 Extended) that can be screwed into the bottom opening of an OL2 and mounted at the top of the tower. A mounting bracket is shown below.



# FTS 371 SMART USER MANUAL

The cable is best secured using the 2,3,4 tape method described in “SECURING THE CABLE” section below.

2. The OL2 may also be secured to the tower by mounting it on a length of ¾” nipple or conduit and securing to tower by means of 2 – 3 U-bolts or beam clamps. The cable is then secured using the 2,3,4 tape method.

## MARKER INSTALLATION AND WIRING

Installation and wiring instruction concerning MKR 371 DC / MKR 372 DC IR marker fixtures are supplied with the marker kit.

## LIGHTNING PROTECTION

All Flash Technology equipment is designed to withstand severe transient over-voltages. However, install a lightning arresting system to prevent eventual damage by lightning. Transient suppressors from line-to-line and line-to neutral are recommended at the primary power load center.

Confirm the presence of a copper lightning rod. Ensure the rod is approx. 18” away from the L-864 red LED beacon and 36” above the beacon for proper protection.

## SYSTEM WIRING

This manual may not contain all the information about installation wiring required for your installation.

**Important!** If installation drawings prepared specifically for your site disagree with information provided in this manual, the site installation drawings should take precedence. Consult any site-specific installation wiring diagrams supplied with your equipment.

All installation wiring should have an insulation rating of 600 volts. Wire size for the lights on each wire run is calculated from the number of lighting fixtures and the length of the wire on that run.

Ensure proper service and drip loops at each location:

- Install a 5’ service loop in the flashhead cable just below the beacon and a separate 5’ service loop at the base of the tower, near the controller
- Install a 5’ service loop in the marker cable near the marker and at the base of the tower, near the controller.
- Ensure drip loops near the beacon, markers and antenna



After the wiring has been terminated ensure all cord grips at beacon, markers and controller are fully tightened and all latches are secured to prevent moisture intrusion.

Flash Technology wiring diagrams define only minimum requirements recommended for satisfactory equipment operation. It is the responsibility of the installer to comply with all applicable electrical codes.

## SECURING THE CABLE (2-3-4 TAPE METHOD)

Flash Technology provides the material for securing the beacon cable to a skeletal structure with the following technique. **NOTE!** Always adhere to local electrical codes that could supersede this technique.

**Table 2.1 – 2-3-4 Tape Method**

Step 1	Step 2	Step 3
		
<p>Run the cable along 1 of the tower legs. Wrap 2 full turns of 2-inch Scotchrap™ #50 tape (or the equivalent) around the cable and tower leg.</p>	<p>Wrap 3 full turns of 1-inch Scotchrap Filament #890 tape over the Scotchrap #50 tape.</p>	<p>Wrap 4 full turns of 2-inch Scotchrap #50 tape over the Scotchrap Filament #890 tape.</p>

**NOTE!** Ensure there is at least a 4-5 foot (1.5 meters) separation between taping sections per NEC.

## FLANGE STRESS RELIEF

Secure the cable above and below each flange approximately 6 inches by performing steps 1 through 3. Allow a 1-inch to 3-inch separation from the flange and the cable.

## AM “HOT” TOWER WIRING

On AM “hot” towers, wire the beacon, markers and controller as described in this section except for the following. On the cable between the controller and beacon, do not connect the ground conductor in the controller or the beacon.

## FLASHHEAD/BEACON WIRING

For AC powered systems, see beacon wiring in [Figure 7](#) (page 29) and typical installation diagrams in [Figure 9](#) (page 30) and [Figure 10](#) (page 31). In the beacon, connect the black wire to PCB terminal L1 and white wire to L2/N. Connect the green ground wire directly to the beacon base using the screw with integrated star washer located near the cable entry point.

For DC powered systems, see beacon wiring in [Figure 13](#) (page 34) and typical installation diagrams in [Figure 14](#) (page 35) and [Figure 15](#) (page 36). In the beacon, connect the red wire to PCB terminal DC+ and black wire to DC-. Connect the blue ground wire directly to the beacon base using the ground terminal installed in the beacon base located near the cable entry point.

Note: Install a 5' service loop in the cable near the flashhead/beacon

## CONTROLLER WIRING

For AC powered systems, see the controller wiring in Figure 6 (page) and typical installation diagrams in [Figure 9](#) (page 30) and [Figure 10](#) (page 31).

For DC powered systems, see the controller wiring in Figure 11 (page) and typical installation diagrams in [Figure 14](#) (page 35) and [Figure 15](#) (page 36).

## INPUT POWER CONNECTIONS

On the FTS 371 FTC SMART controller, the input power will be connected to J1.

AC systems are not sensitive to input power phase and have an operational voltage range of 85-265 VAC, 50/60 Hz with no modification necessary to the input power module. The (2) 10A replaceable input power fuses are located on F1 and F2. To remove a fuse, disconnect power then push in and turn counterclockwise.

On DC systems, observe polarity of input voltage and connect positive to DC+ and negative to DC-. There is one replaceable input power fuse located at F1. To remove the fuse, disconnect power then push in and turn counterclockwise.

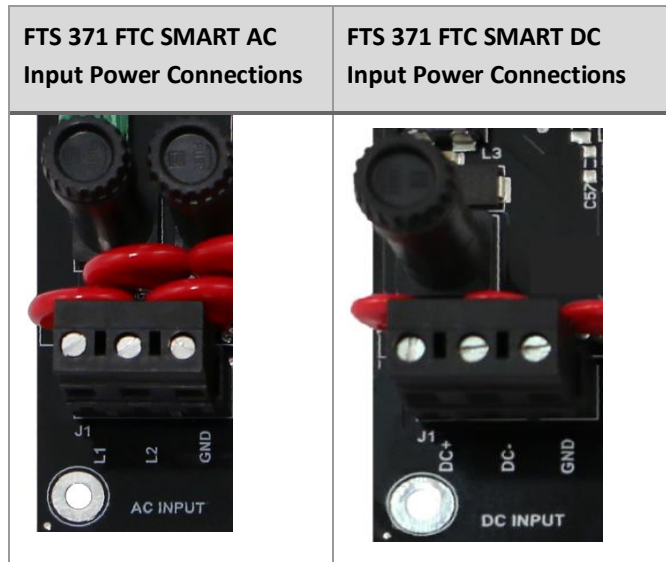

## BEACON AND MARKER CONNECTIONS

On the FTS 371 FTC SMART controller, the beacon connections are at J2 and marker connections are at J3.

For AC powered systems, up to two FTS 371 FH AC IR beacons may be connected. Connect the black wire to J2 terminal L1 and white wire to L2. Connect the green ground wire directly to the controller backplate using the ground terminal installed near the Beacon PCB connector. **Note:** Some PCBs have a ground terminal (GND) on the PCB J2 connector which is not used if the ground conductor is connected to the backplate.

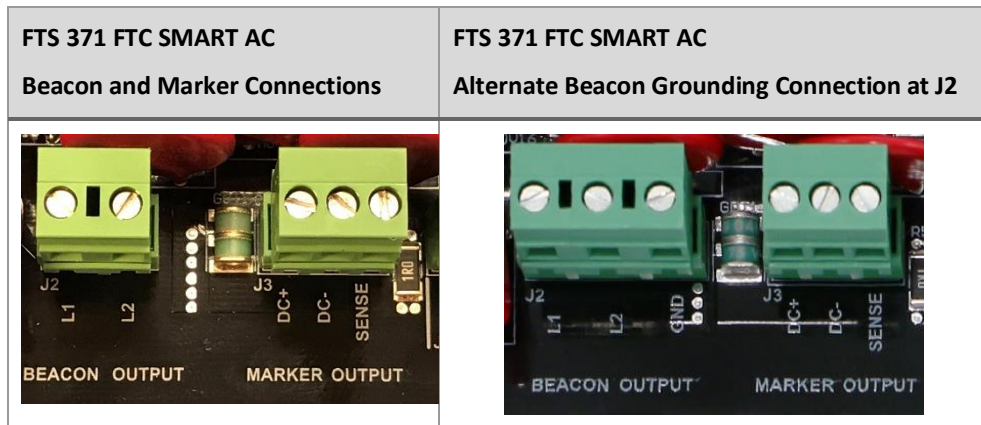

# FTS 371 SMART USER MANUAL

For DC powered systems, one FTS 371 FH DC IR beacon may be connected. Connect the red wire to J2 terminal DC+ and black wire to DC-. Connect the blue ground wire directly to the controller backplate using the ground terminal installed near the beacon PCB connector.

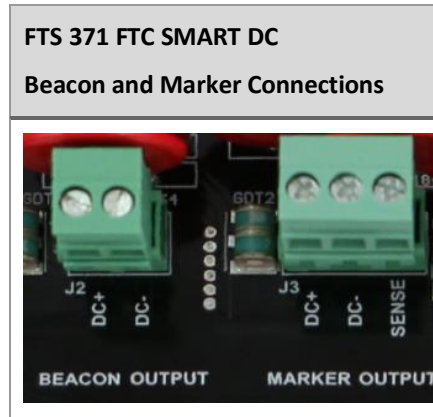

Up to eight of the MKR 371 DC / MKR 372 DC IR series marker lights may be powered from the MARKER OUTPUT at J3. Connect the red wire to DC+, black wire to DC- and WHT/BLU wire to SENSE. Connect the bare (non-insulated) shield wire directly to the controller backplate using the ground terminal installed near the beacon PCB connector.

**Note:** The beacons or markers are powered if wired to the connectors. The configuration switches and jumpers configure alarming.

---

## DRY CONTACT MONITORING AND PHOTODIODE CONNECTIONS

Find the dry contact monitoring connections on J4 and J5. The FTS 371 controller allows the option to have a BEACON, MARKER and PHOTODIODE alarm point available for external monitoring. Also included is the MODE relay connections that allow remote notification of mode change via a dry contact.

The photodiode (PHD 516) will connect to the far right of J5. If necessary, prepare the photodiode cable by stripping jacket and removing foil shield from black, clear and drain wires. Connect the wires to matching labels on the PCB for proper operation (Clear to WHT, Black to BLK and drain wire to SHLD).

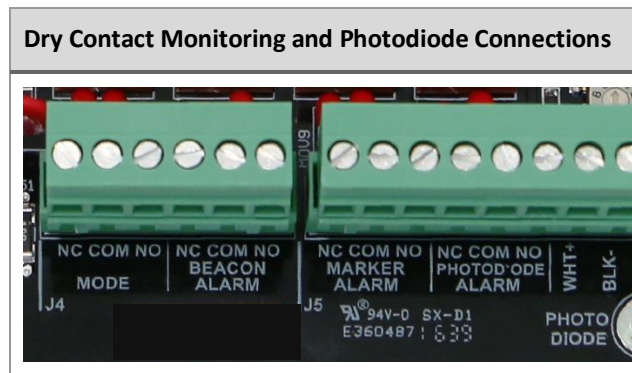

---

## RADAR AND PRIMARY/SECONDARY CONNECTIONS

The SYNC connector J7 can be used to provide either beacon inhibit control by an external RADAR input or primary/secondary synchronization with multiple controllers. Only one of these features is available at a time.



# FTS 371 SMART USER MANUAL

When the RADAR configuration switch is placed in the ON position, an external device such as a radar system may inhibit the output of the beacon. Wire the dry contact from the external device to connector J7 terminals with IN+ and OUT+ as shown below and jumper the terminals IN- to OUT-. The fail-safe design requires a closed contact to inhibit the output of the beacon so the beacon is on if the contact is open and off if closed.

For primary/secondary synchronization, set the RADAR configuration switch to the OFF position and wire the J7 SYNC connector to other controllers as shown below, primary OUT+ and OUT- to secondary #1 IN+ and secondary #1 IN-, etc. Each secondary must have its secondary configuration dipswitch set to ON and its flash configuration set to match the primary: flash type (efficiency/legacy), flash spec (FAA/ICAO) and beacon and marker flashing/steady. Secondary units with nonmatching configuration will not flash in unison with the system. A photodiode is connected to the primary controller only, not the secondary unit.

**Note:** The EXT SYNC LED is on at the beginning of SYNC pulse and off at end of SYNC pulse on both primary and secondary. The secondary's EXT SYNC LED will flash ON only if properly wired to primary so is a good troubleshooting check.

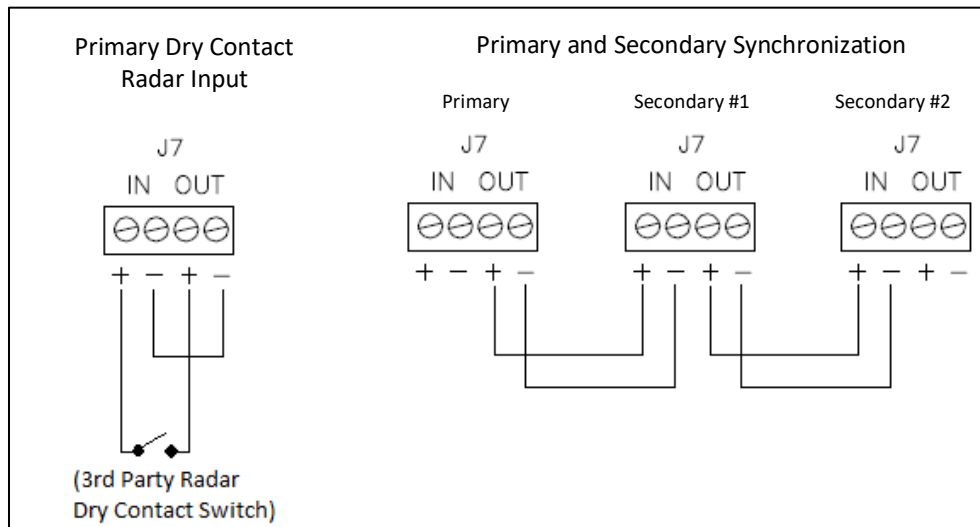

## CATENARY OPERATION

For catenary operation, wire the systems as shown above and set the configuration switches as in the table below. Note that for the Middle level, both CAT T and CAT B switches should be set to OFF.

	Primary (CAT TOP)	Secondary #1 (CAT MID)	Secondary #2 (CAT BOT)
<b>SECONDARY</b>	OFF	ON	ON
<b>RADAR</b>	OFF	OFF	OFF
<b>60FPM</b>	ON	ON	ON
<b>CAT T</b>	ON	OFF	OFF
<b>CAT B</b>	OFF	OFF	ON

## GPS SYNCHRONIZATION

For GPS synchronization, the optional GPS Sync Kit must be installed including external GPS antenna mounting. Refer to the FTS 371 GPS Sync Kit (P/N 1370285) Installation Instructions for details.

The portion outlined in red shows the location of the FTS 371 GPS OPTION PCB PN 2433000 on the controller PCB.

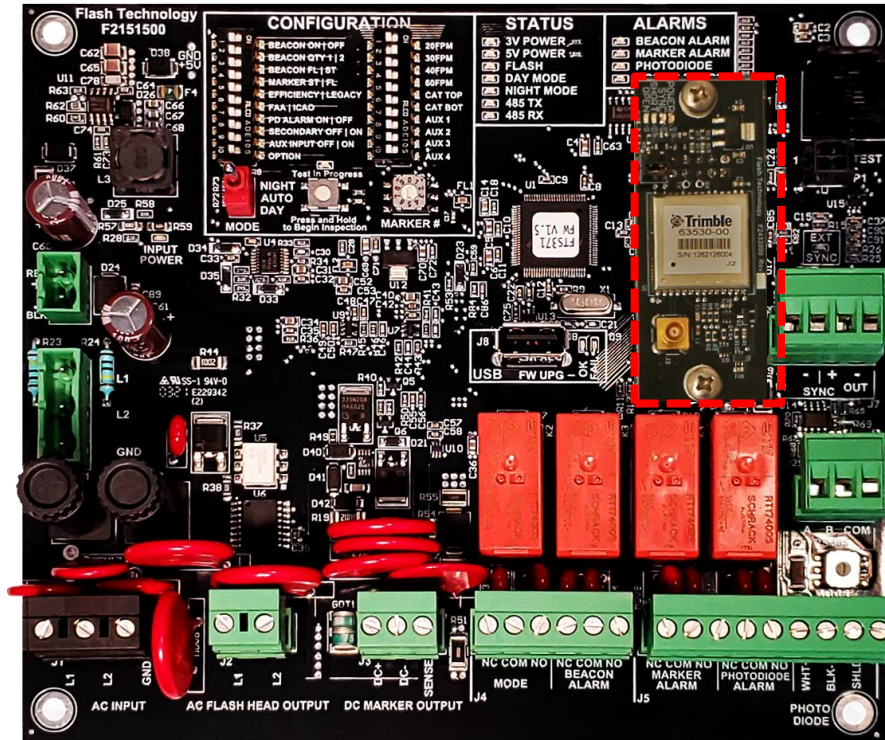

## GPS Configuration and Test Instructions:

1. Configure the GPS PCB:
  - a. For synchronization with Flash Technology products, do not install the jumper on H1 or H2. Or install the jumper on one pin only.
  - b. For synchronization with Orga products, install the jumper on H1 (covering both pins).
  - c. For synchronization with Unimar products, install the jumper on H2 (covering both pins).
2. Apply power to the FTS 371 Controller.
3. View the LEDs on the GPS board to determine operational status.

LED Indicator	LED Description
POWER	Lit (green) if GPS board is powered
SYNC	Lit (green) when GPS Sync is achieved. May take up to 10 minutes after power up. If not lit, check that antenna has an unobstructed view of the sky.
OPEN	Lit (red) indicates cable or antenna not connected or damaged.
SHORT	Lit (red) indicates cable or antenna is shorted and defective.

## RS-485 MODBUS RTU COMMUNICATION

Advanced monitoring of the FTS 371 SMART controller is available by RS-485 Modbus RTU communication interface available at connector J6. The FTS 371 SMART system controllers are configured to be a Modbus secondary device. The controller includes a rotary switch on the bottom right to accommodate multiple FTS 371 SMART systems to be monitored through Modbus. This rotary switch specifies the Modbus secondary address with values 1 through 10 (switch positions 1 to 9 address as 1 to 9 and switch position 0 addresses as 10). When multiple FTS 371 controllers are used, they must be addressed and monitored individually. Data is not collated from secondary units to the primary.

See the [Technical Bulletin – FTS 371 SMART Modbus Interface](#) for detailed specification.

## INSTALLATION CHECKLISTS

**Table 2.2 – System Installation Checklist**

<input type="checkbox"/>	All equipment has been inspected for damage
<input type="checkbox"/>	All received equipment has been verified against the packing list to ensure completeness
<input type="checkbox"/>	Site installation drawings have been consulted for placement, mounting and wiring details
<input type="checkbox"/>	A power disconnect switch or a circuit breaker has been provided
<input type="checkbox"/>	A lightning protect system is in place
<input type="checkbox"/>	Junction boxes have been ensured to drain condensation properly
<input type="checkbox"/>	Controller has been mounted and positioned to allow adequate clearance to open the cover
<input type="checkbox"/>	Controller has been mounted upright
<input type="checkbox"/>	All screws within the internal controller hardware are tight
<input type="checkbox"/>	No holes have been punched or drilled on the top of the controller enclosure
<input type="checkbox"/>	The photodiode has been located where it has an unobstructed view of the polar sky (north).
<input type="checkbox"/>	Photodiode is located where it will not view direct or reflected artificial light
<input type="checkbox"/>	Photodiode is supported directly by electrical conduit or mounted on the optional Antenna Mounting Bracket (Kit PN 1905355).
<input type="checkbox"/>	Photodiode is not mounted underneath the controller where it could be shadowed
<input type="checkbox"/>	Photodiode installation is water tight
<input type="checkbox"/>	<b>AM Towers Only:</b> If the AM tower is “hot,” do NOT connect the ground wires to the beacon power connector or the controller beacon power connector.

**Table 2.3 – Before Applying Power Checklist**

<input type="checkbox"/>	Examine installation drawings.
<input type="checkbox"/>	Verify incoming service voltage is the value stated on the ID plate.
<input type="checkbox"/>	Ensure the unit is wired according to the included instructions.
<input type="checkbox"/>	Check all electrical connections for tightness.
<input type="checkbox"/>	Check all terminal strip connections for tightness.
<input type="checkbox"/>	If external alarm detection circuit responds to closed contacts, ensure they are wired to the proper contacts that close on alarm.
<input type="checkbox"/>	If external alarm detection circuit responds to open contacts, ensure they are wired to the proper contacts that open on alarm.
<input type="checkbox"/>	Verify alarm wiring has been protected by using shielded wires. Also verify proper grounding of the shield wire, and that the wires are ran through conduit.
<input type="checkbox"/>	Ensure the white wire of the photodiode is connected to J4 terminal labeled WHT+ and the black wire is connected to J4 terminal labeled BLK-.

## CHECKOUT PROCEDURE

### LIGHTING INSPECTION

The FTS 371 FTC SMART has a built in test procedure to aid in performing lighting inspections (LI). The automated test eliminates the need to disconnect any wires from the unit to test alarm points. The following inspection will only test devices that the controller is configured for.

# FTS 371 SMART USER MANUAL

Start the LI by pressing the white Inspection button, which is located in the bottom center of the “Configuration” box and to the right of the MODE switch. The automated LI first tests the beacon (if configured), then the markers (if configured) and finally the photodiode alarm. During the beacon and marker tests, the corresponding output is turned off (beacon or marker turned Off) and the controller confirms that an alarm is properly generated (four missed flashes are required to trigger an alarm). Then the output is turned back on (beacon or marker turned On) and the controller confirms that the alarm is properly cleared (four good flashes are required to clear an alarm). If no beacons or markers are configured, these steps will be skipped and only the photodiode alarm will be tested.

**Important!** Before attempting to perform the LI, verify that the PCB configuration switches are properly set including that the beacon and marker switches match the number of connected beacons and markers. See the [Section 4 - Operating Instructions](#) (page 41) for details of switch settings.

**Important!** During each step of the LI process described below, the technician must confirm that the ALARM LED comes on and goes off as described. The ALARM LED for each section of the test must come ON and go OFF as described for a successful lighting inspection.

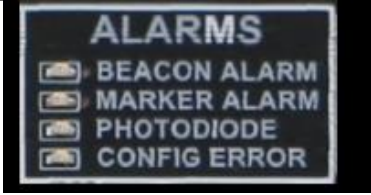
LI Inspection Button	Alarm Indication LEDs
	

## LIGHTING INSPECTION PROCEDURE

1. To begin, press and hold the white inspection button for 3+ seconds until the “Test in Progress” LED begins flashing then release the button. The “Test in Progress” LED will blink throughout the entire lighting inspection as an indication that the LI is still underway. The LI may be cancelled at any time by pressing the inspection button for 3+ seconds.
2. Press the white inspection button (one quick press) to activate the first alarm.
3. If beacons are configured (BCN ON/OFF configuration switch is set to ON), the following steps are performed. If switch is set to OFF, this test is skipped.
  - a. Confirm Beacon Alarm - The BEACON ALARM LED will flash as the alarm is being generated (four missed flashes required). Once the alarm is active the BEACON ALARM LED will be lit solid. The technician must verify that the BEACON ALARM LED comes on solid.
  - b. Clear Beacon Alarm - To restore (clear) the alarm, press the inspection button (one quick press). Once the alarm is cleared (four good flashes required), the BEACON ALARM LED will be OFF. The technician must verify that the BEACON ALARM LED goes OFF.
4. Press the white inspection button (one quick press) to activate the next alarm.
5. If markers are configured (MARKER # rotary configuration switch is set to a number other than zero), the following steps are performed. If switch is set to zero, this test is skipped.
  - a. Confirm Marker Alarm - The MARKER ALARM LED will flash as the alarm is being generated (four missed flashes required). Once the alarm is active, the MARKER ALARM LED will be lit solid. The technician must verify that the MARKER ALARM LED comes ON solid.
  - b. Clear Marker Alarm - To restore (clear) the alarm, press the inspection button (one quick press). Once the alarm is cleared (four good flashes required), the MARKER ALARM LED will be OFF. The technician must verify that the MARKER ALARM LED goes OFF.

## FTS 371 SMART USER MANUAL

6. Press the white inspection button (one quick press) to activate the photodiode alarm. If the photodiode alarm configuration switch (PD AL) is set to OFF, this test is skipped. **Note:** This test does not check the photodiode itself or connections; it only turns asserts the photodiode alarm so that the alarm relay connections can be tested.
  - a. The technician should verify that the photodiode alarm relay indicates an alarm (J5 PHOTODIODE ALARM NC to COM is open).
  - b. To restore (clear) the photodiode alarm, quickly press the inspection button one time. The technician should verify that the photodiode alarm relay indicates no alarm (J5 PHOTODIODE ALARM NC to COM is connected).
7. Press the white inspection button (one quick press) once more to finish the automated portion of the LI. The "Test in Process" LED should go OFF.
8. Manual Photodiode Test
  - a. Set the MODE switch to AUTO. This ensures that the system is now under photodiode control.
  - b. Cover the photodiode to block it from all light and wait up to 60 seconds.
  - c. Verify that the "STATUS" LEDs show that the system is now in NIGHT mode.
  - d. Verify that the beacon and/or marker(s) connected to the controller are on and operating as programmed.
    - i. Uncover the photodiode to allow light to strike it, or shine a light on it. With no alarms or errors, verify that after a delay,
      1. The "STATUS" LEDs show the system is now in DAY mode
      2. The beacon(s)/marker(s) connected to the controller are off.

**Important!** The Lighting Inspection is PASSED only if all of the following occur:

- The BEACON alarm LED comes ON and goes OFF as described (step 2-3).
- The MARKER alarm LED comes ON and goes OFF as described (step 4-5)
- The photodiode alarm relay changes states to indicate an alarm as described (step 6).
- The system changes modes properly as described in manual photodiode test (step 8).

If any part of the lighting inspection fails, see [Section 4 - Operating Instructions](#) (page 41) and verify that the configuration switches for the beacon and marker match the number of connected beacons and markers. If this is correct, troubleshoot the system using procedures provided in section 4.

# FTS 371 SMART USER MANUAL

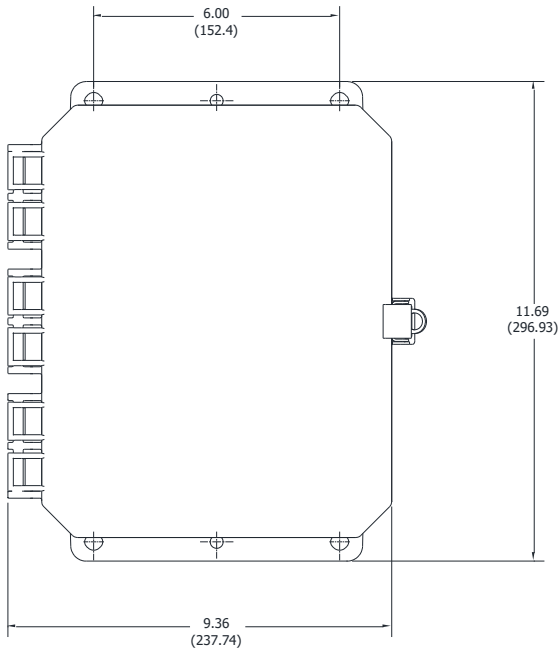

**FRONT VIEW**

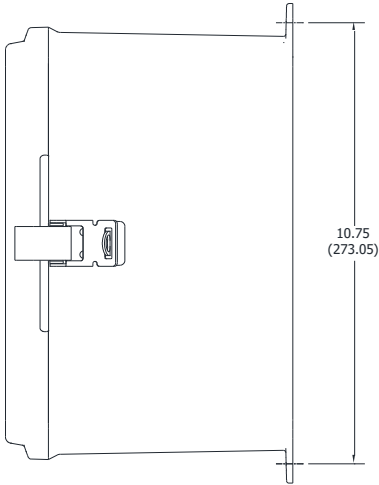

**RIGHT SIDE VIEW**

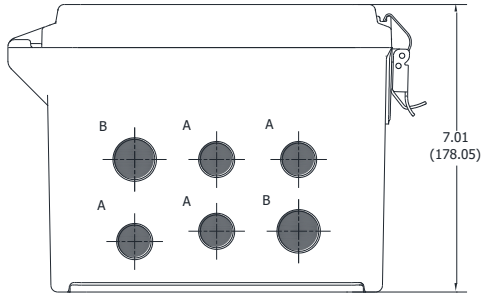

**BOTTOM VIEW**

KNOCKOUT TABLE		
LETTER	KNOCKOUT SIZE (DIA)	QTY
A	0.875 (22.4)	4
B	1.093 (27.8)	2

Figure 1 – Controller FTS 371 SMART Poly Enclosure Mounting and Outline

# FTS 371 SMART USER MANUAL

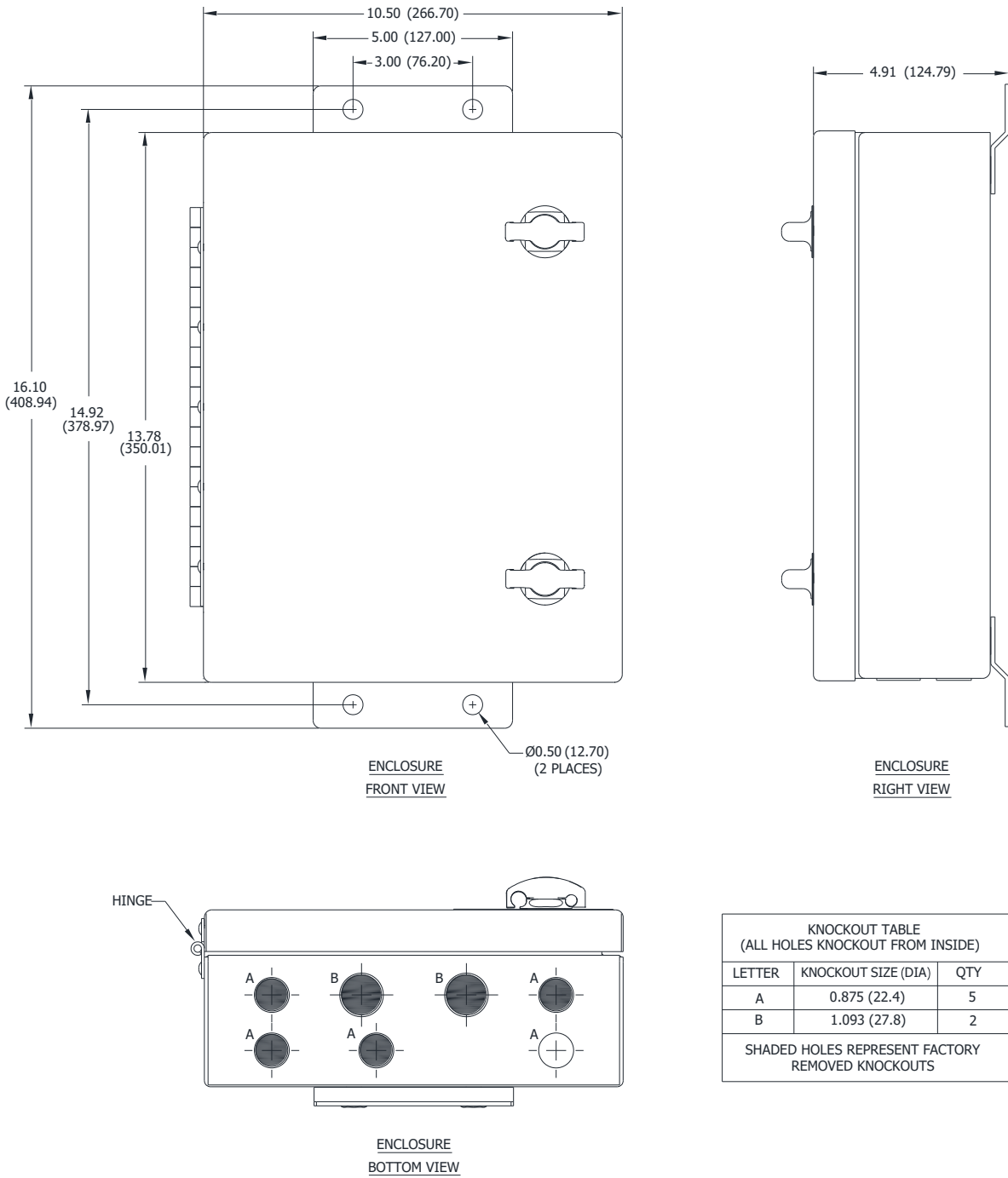

Figure 2 – Controller FTS 371 SMART Aluminum Enclosure Mounting and Outline

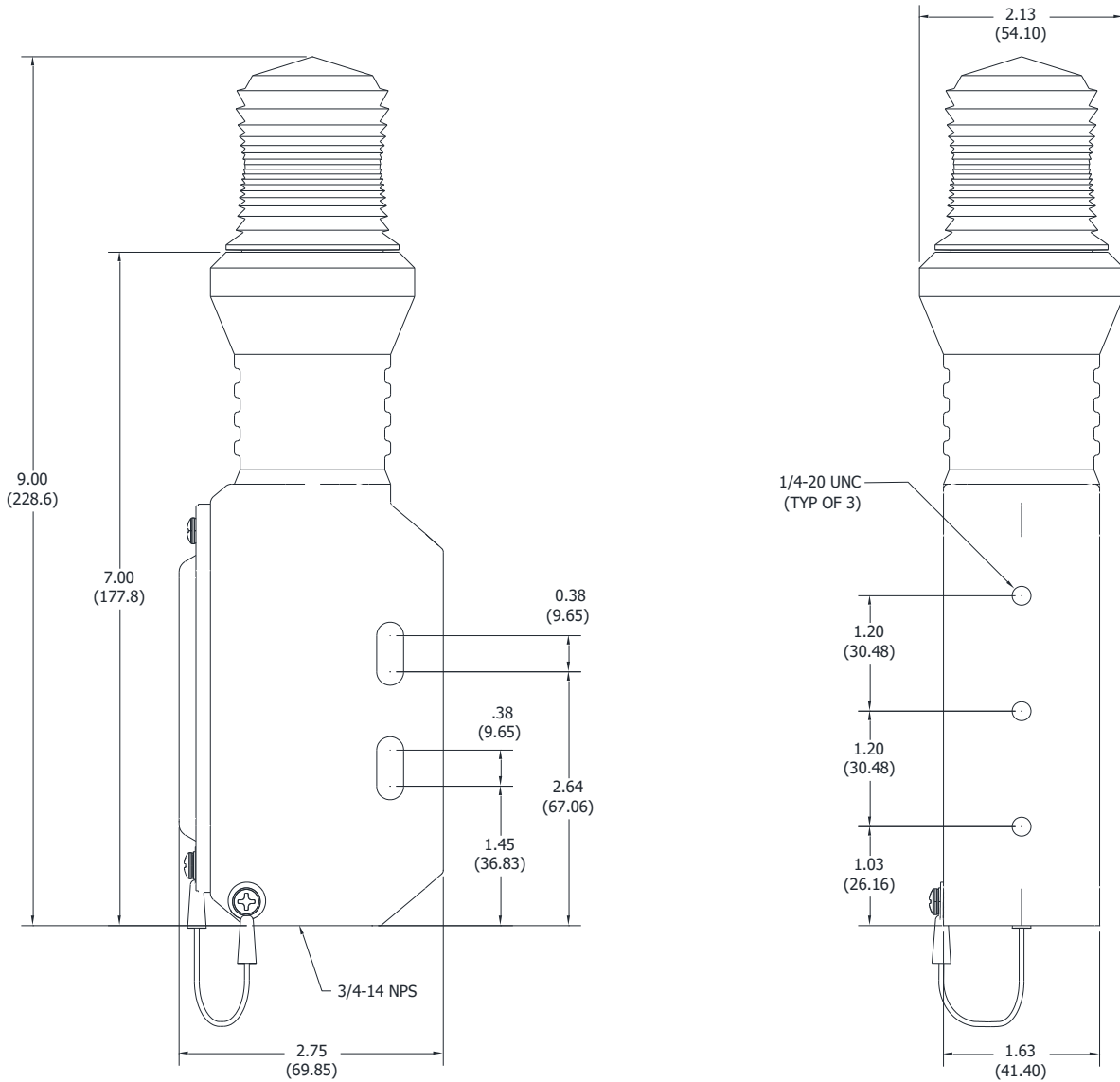

Figure 3 – Marker MKR 371 / MKR 372 IR series mounting and outline view



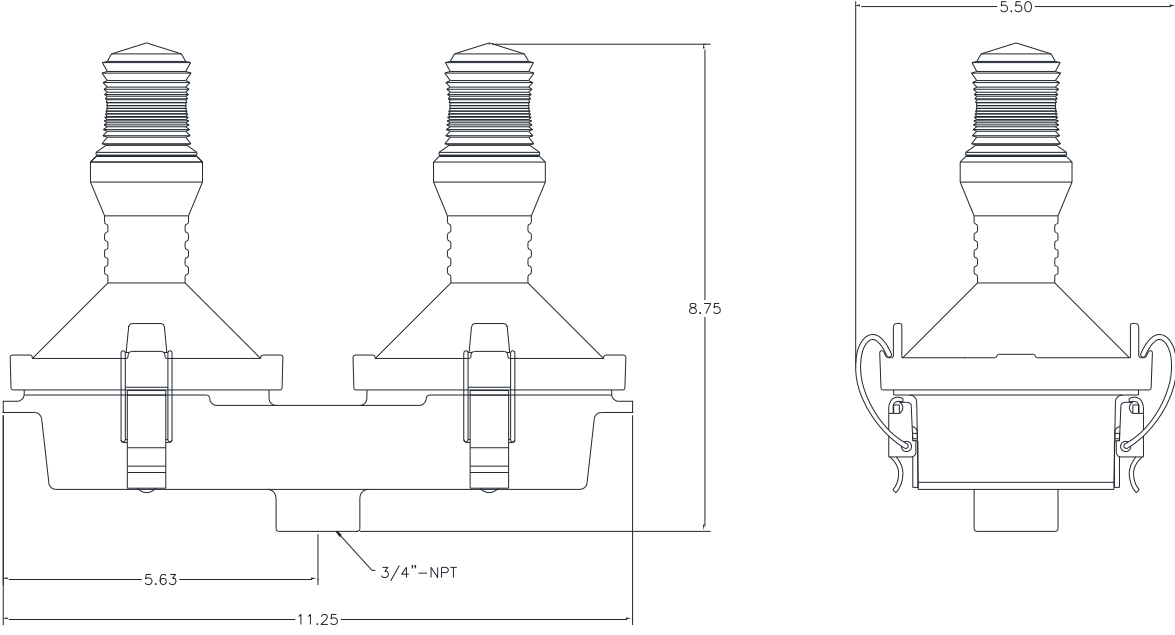

Figure 4 – OL2 mounting and outline view

# FTS 371 SMART USER MANUAL

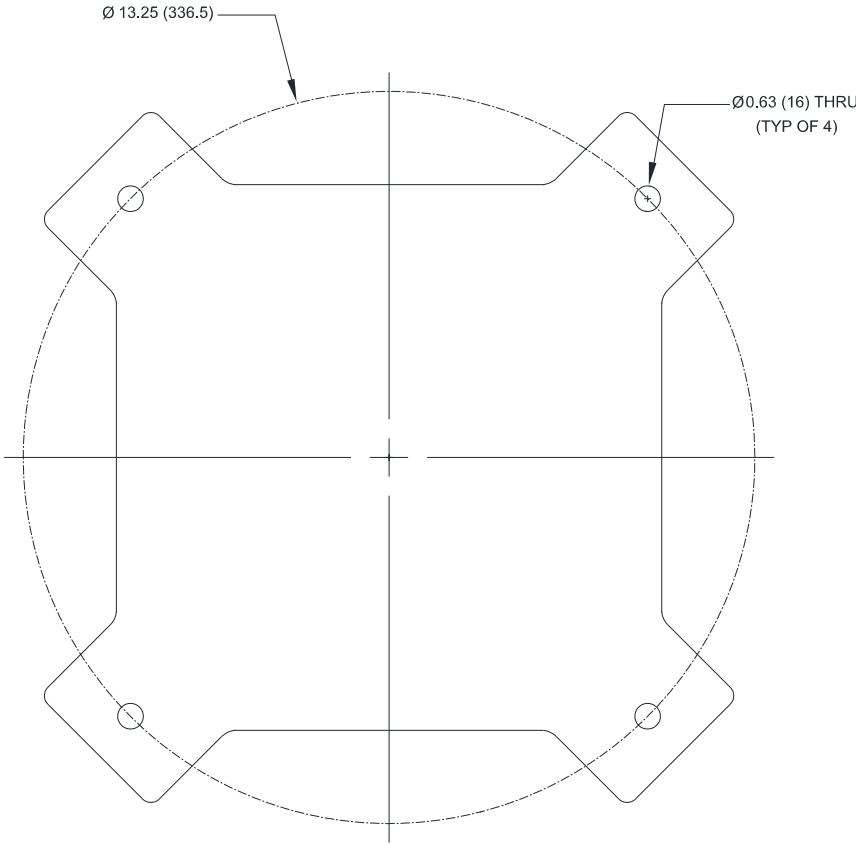
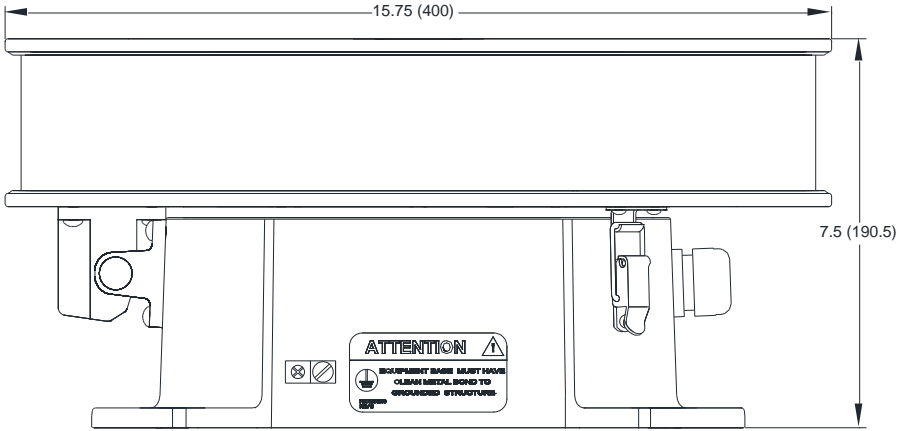

Figure 5 – Flashhead/Beacon FTS 371 FH mounting and outline view

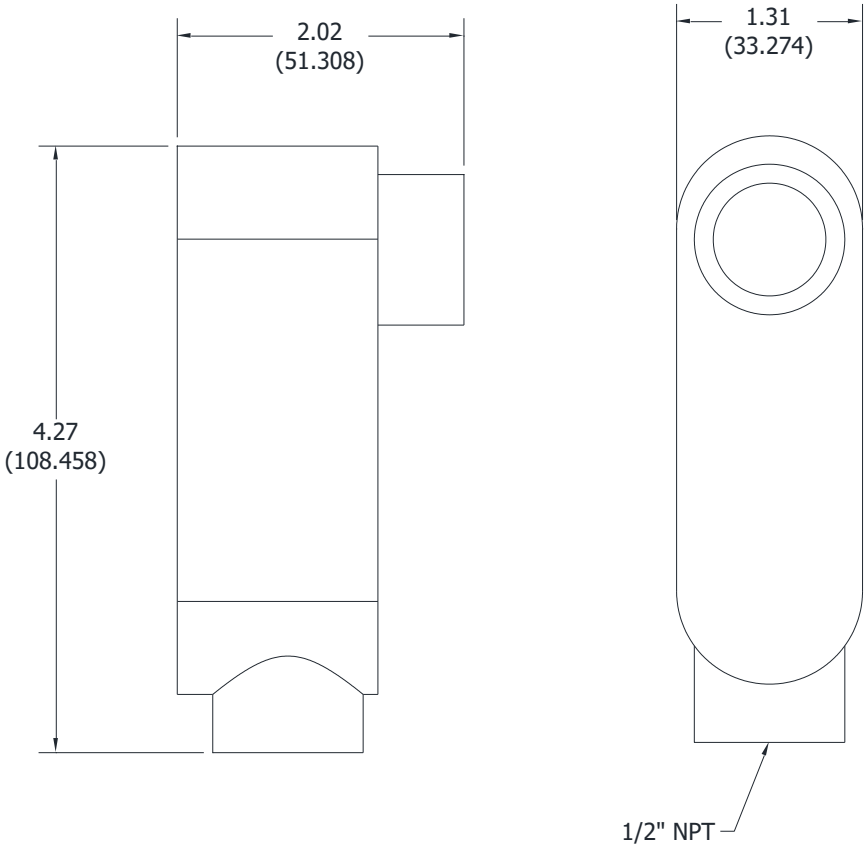
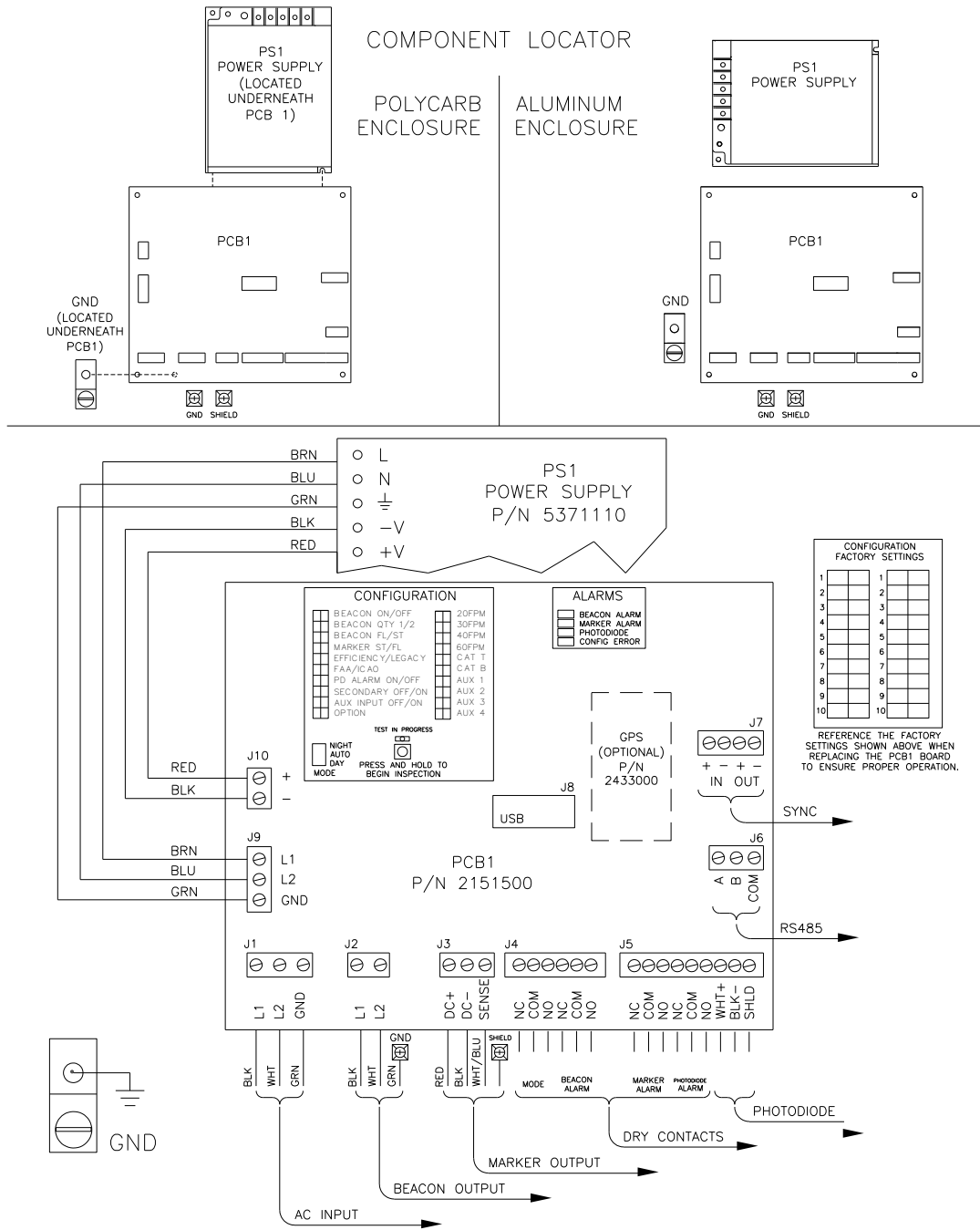

Figure 6 – Photodiode PHD 516 mounting and outline view

# FTS 371 SMART USER MANUAL



FTS 371 FTC SMART AC INTERNAL WIRING

Figure 7 – Controller FTS 371 FTC SMART AC Connection Diagram

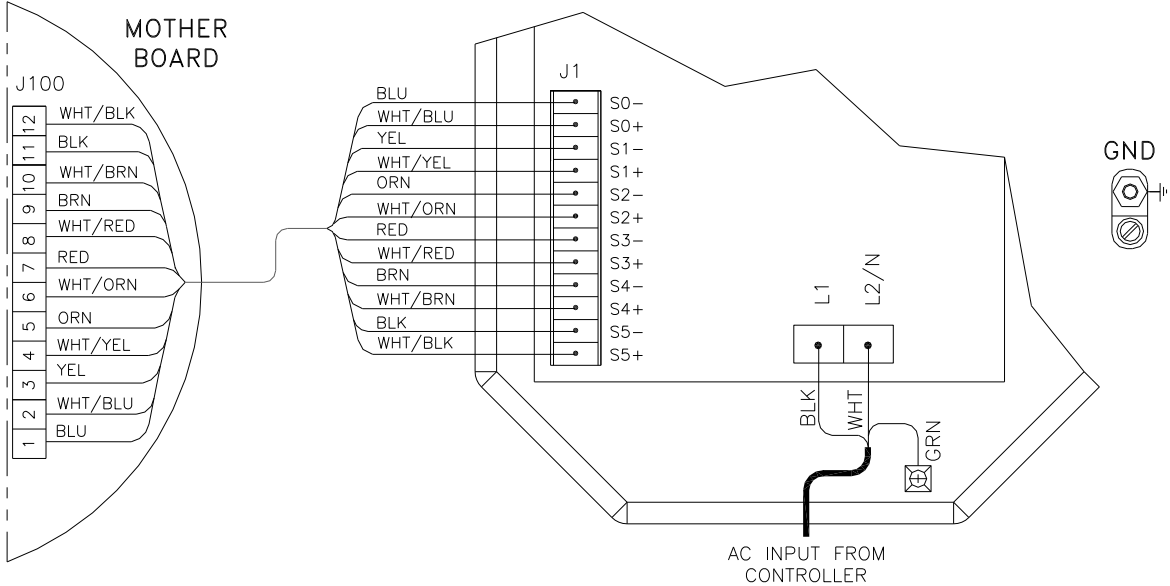

Figure 8 – Flashhead/Beacon FTS 371 FH AC Connection Diagram



# FTS 371 SMART USER MANUAL

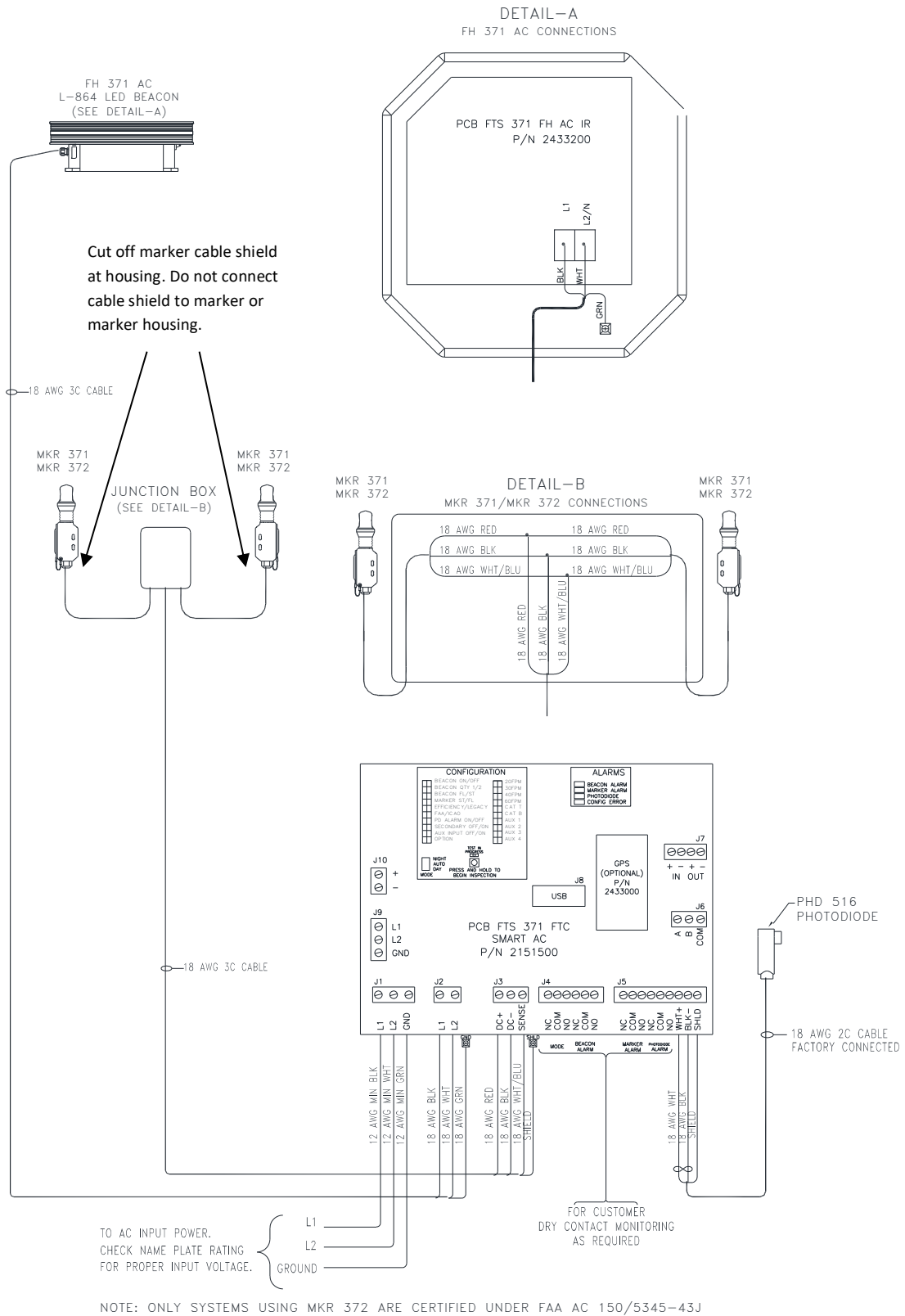
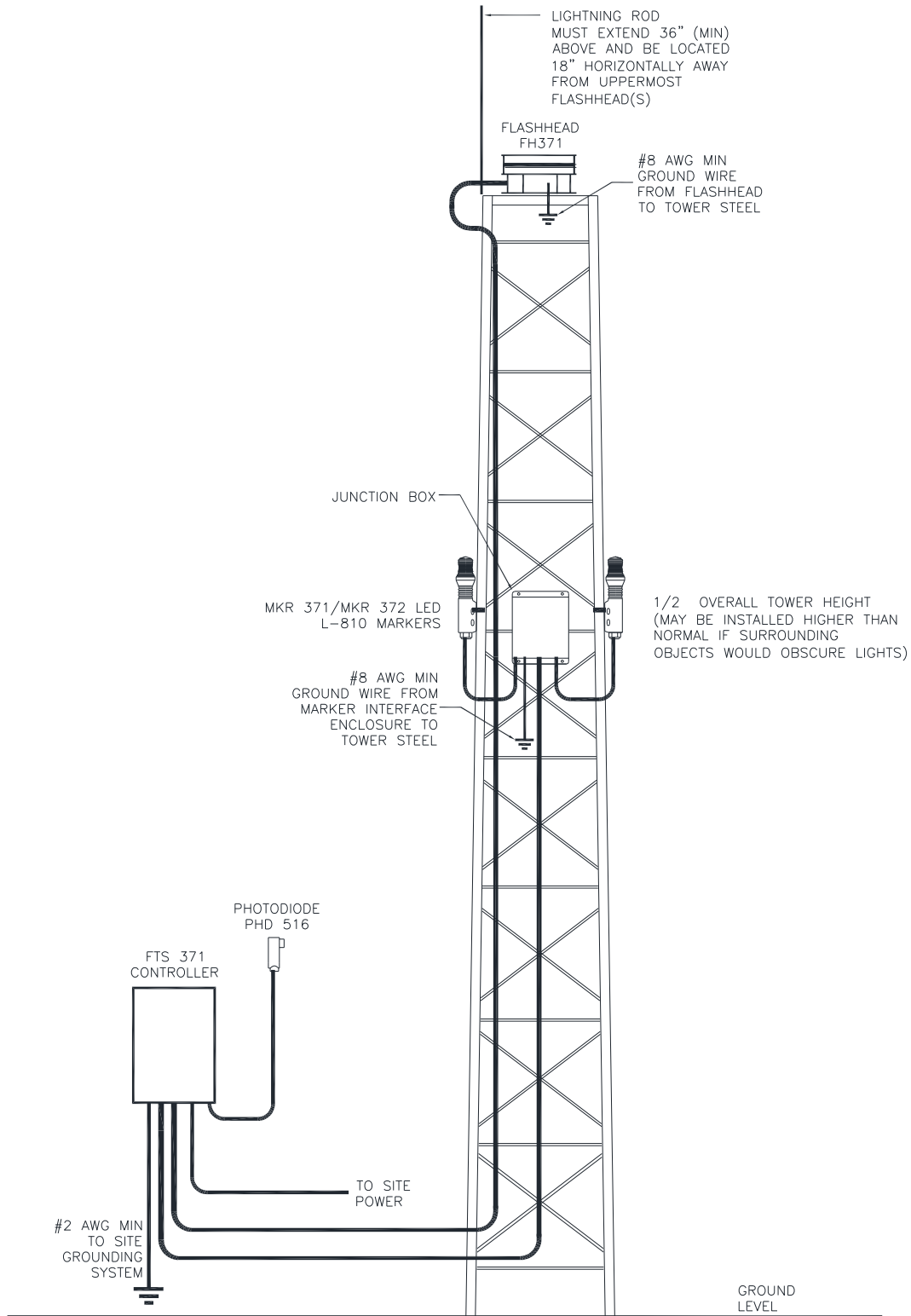

Figure 10 – FTS 371 SMART AC Typical FAA Type A1 Installation Wiring

# FTS 371 SMART USER MANUAL



NOTE: ONLY SYSTEMS USING MKR 372 ARE CERTIFIED UNDER FAA AC 150/5345-43J

Figure 11 – FTS 371 Typical A1 Tower View



# FTS 371 SMART USER MANUAL

## COMPONENT LOCATOR

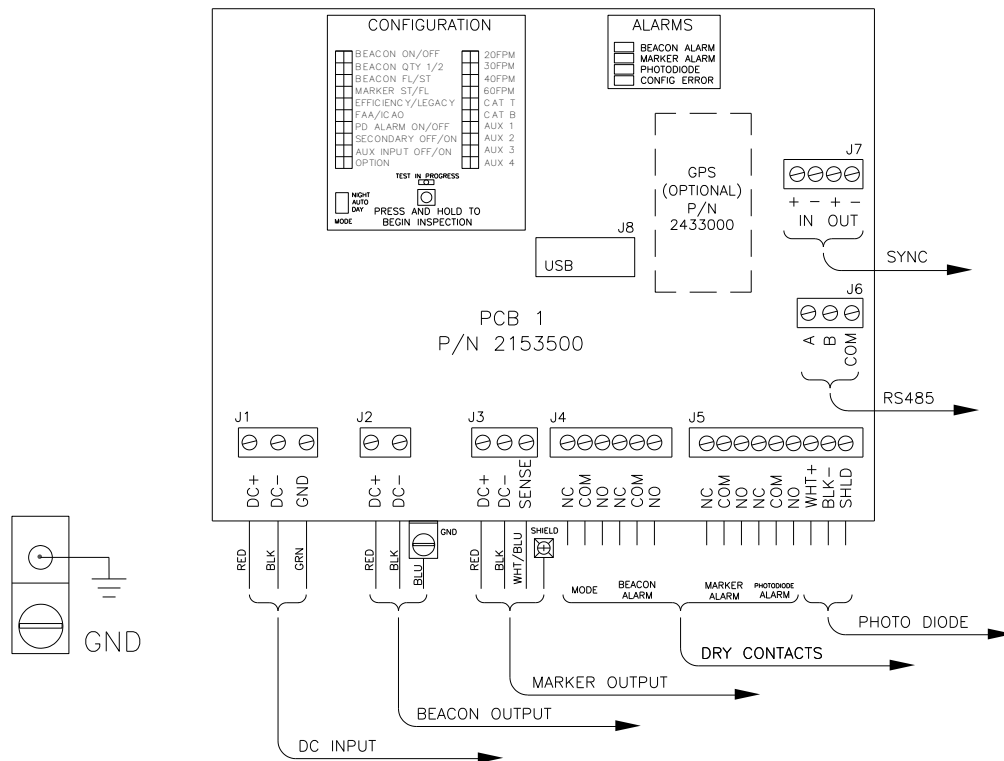
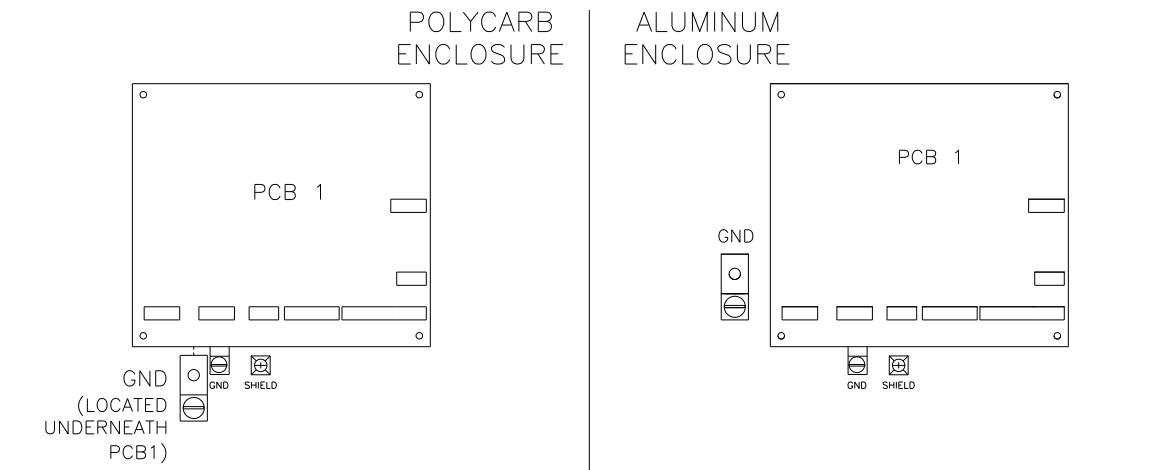

FTS 371 SMART DC FTC INTERNAL WIRING

Figure 12 – Controller FTS 371 SMART DC Connection Diagram

# FTS 371 SMART USER MANUAL

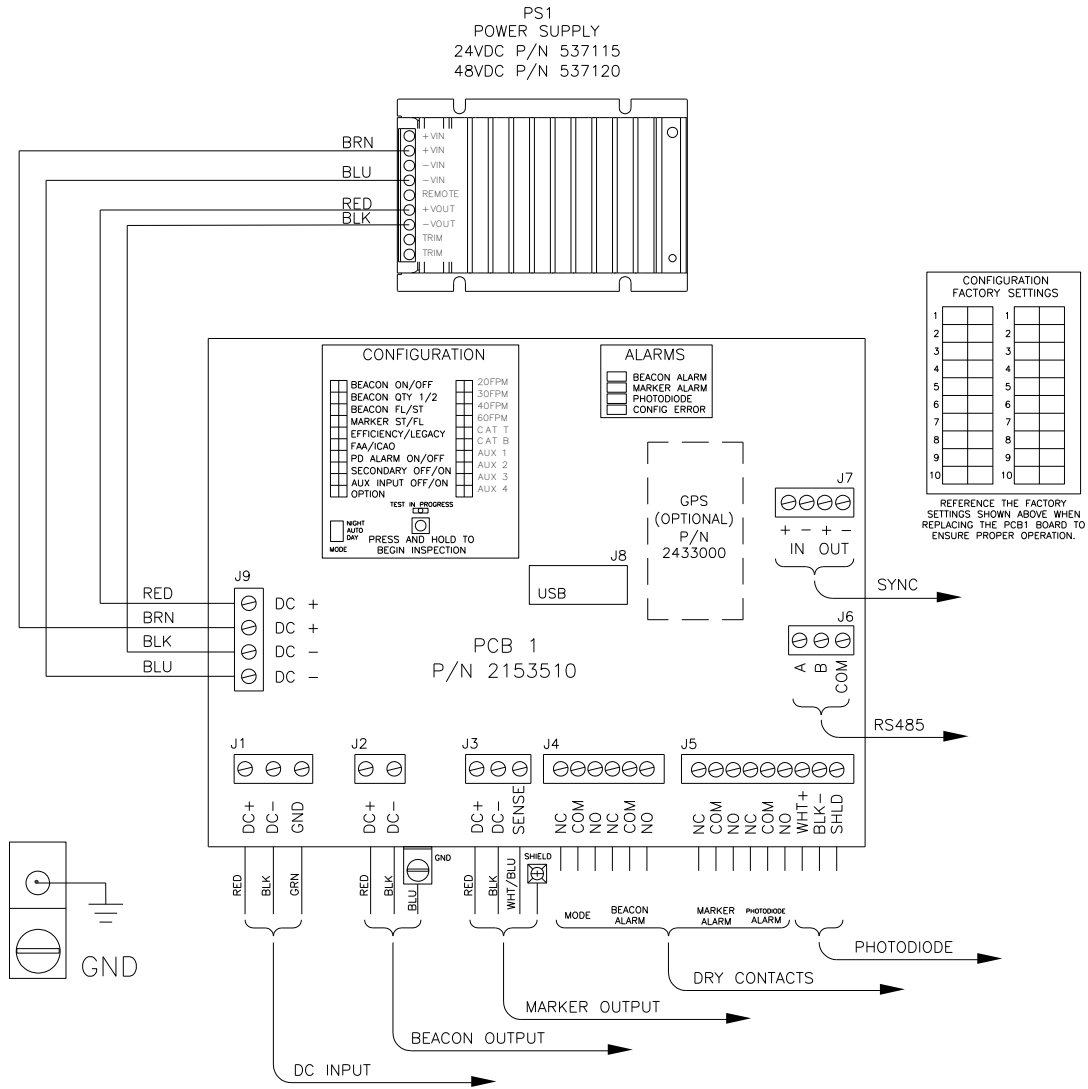

FTS 371 FTC SMART DC (-)  
COMPONENT LOCATOR & INTERNAL WIRING

Figure 13 – Controller FTS 371 SMART DC (-) Connection Diagram

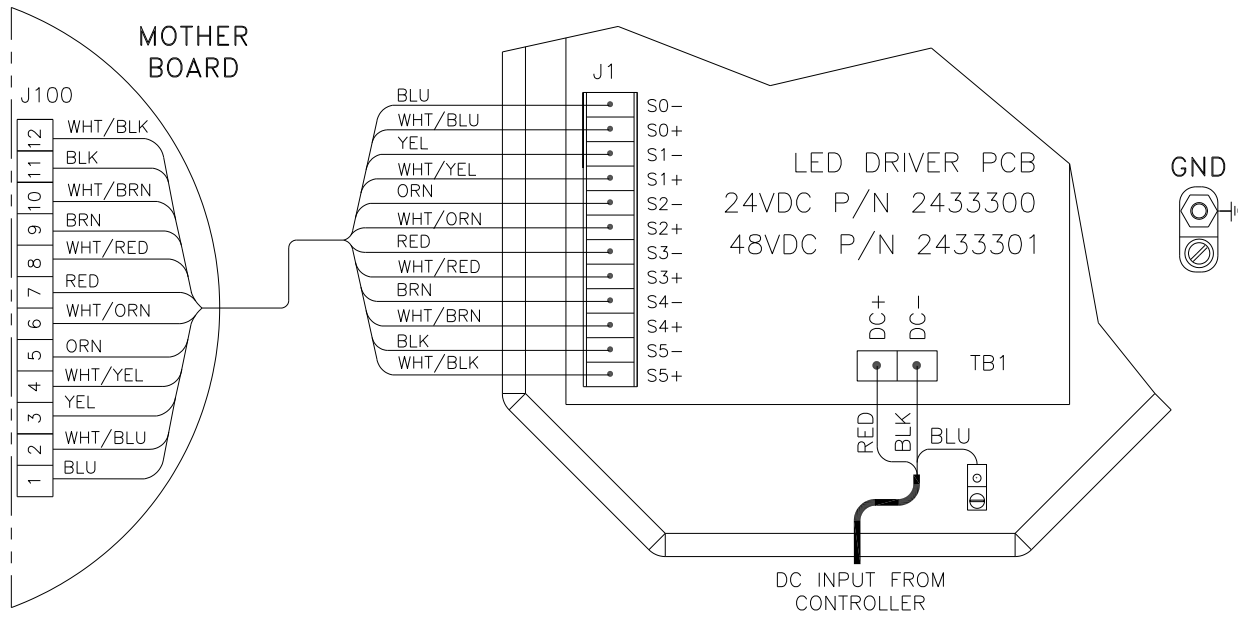
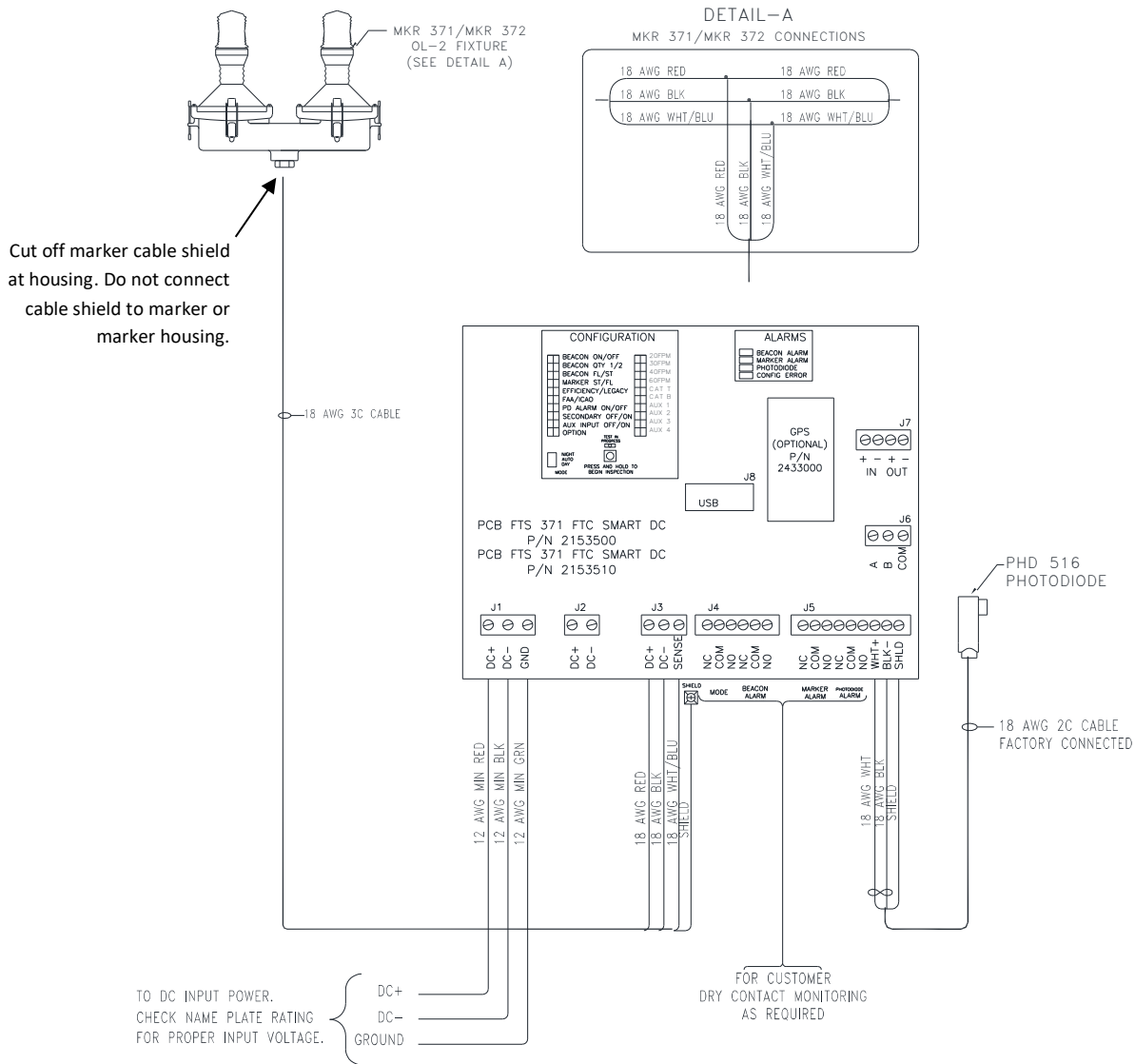

Figure 14 – Flashhead/Beacon FTS 371 FH DC Connection Diagram

# FTS 371 SMART USER MANUAL



NOTE: ONLY SYSTEMS USING MKR 372 ARE CERTIFIED UNDER FAA AC 150/5345-43J

Figure 15 – FTS 371 SMART DC Typical FAA Type A0 Installation Wiring

# FTS 371 SMART USER MANUAL

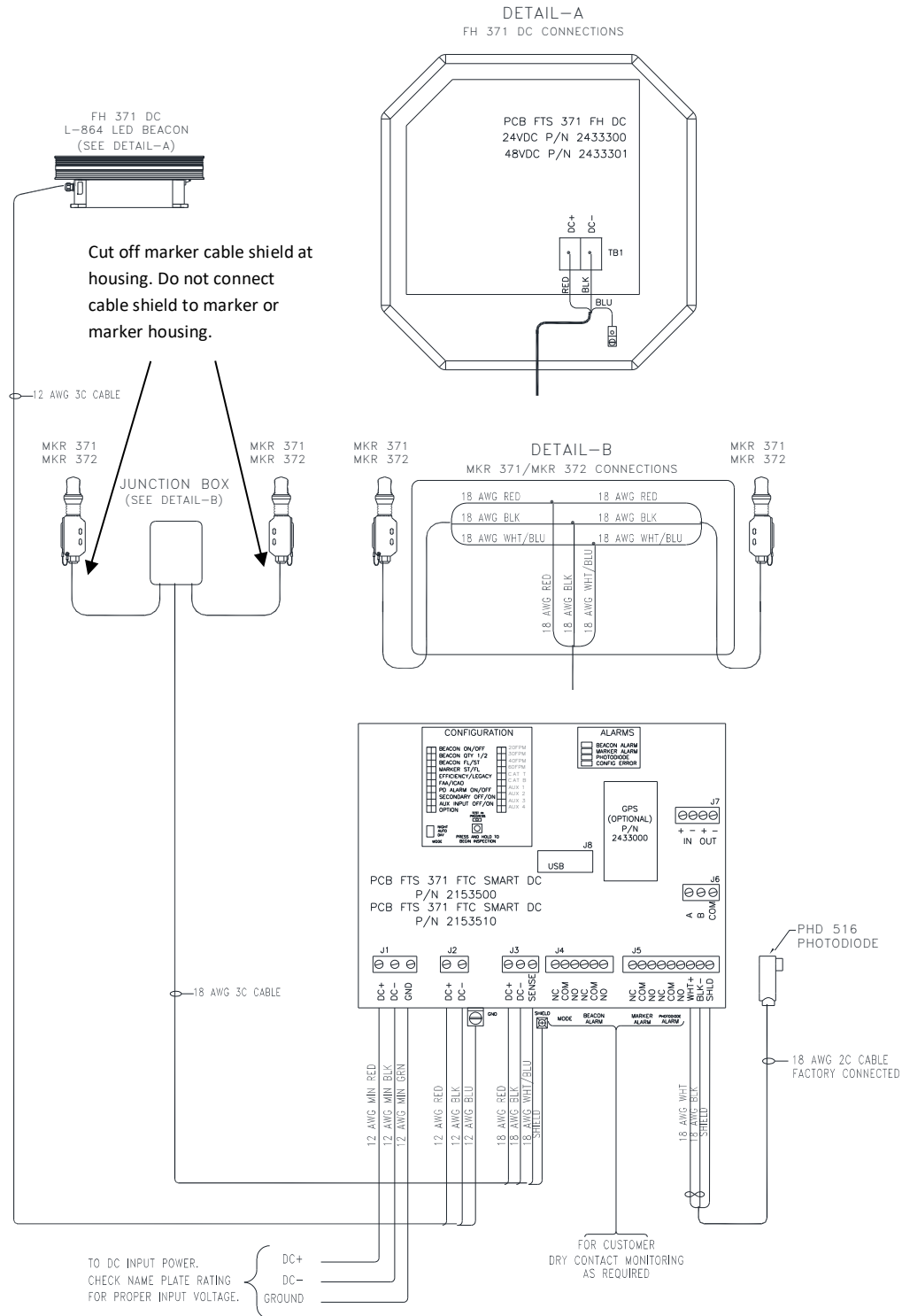

Figure 16 – FTS 371 SMART DC Typical FAA Type A1 Installation Wiring

## SECTION 3 – MAINTENANCE INSTRUCTIONS

### SAFETY

**Warning!** Read the [Personal Hazard Warning](#) now (Page 3). Disconnect primary power before opening enclosures. Work safely, as follows:

1. Remove rings and watches before opening the equipment.
2. Shut off the equipment and wait one minute before proceeding.
3. Remove the component or connect the test instruments.
4. Replace the component.
5. Turn on the power and test the system.
6. Turn off the power and disconnect the test equipment.

---

### MAINTENANCE

Keep the circuit boards free of accumulated dust. Brush and vacuum as necessary. **Note:** Do not use compressed air to clean this equipment.

---

### TROUBLESHOOTING

The most effective troubleshooting procedure begins with observing the behavior of the system. This often leads directly to a faulty component or other abnormal condition.

[Table 4.5 – Troubleshooting](#) (page 45) contains information to help locate the cause of a problem.

---

### COMPONENT REMOVAL AND REPLACEMENT

Note the wiring connections and wire colors when you remove wires from their connections. Replace them exactly as they were.

---

#### FTS 371 FTC SMART CONTROLLER

---

PCB1 (2151500 FTS 371 FTC SMART AC) (2153500 FTS 371 FTC SMART DC) (2153510 FTS 371 FTC SMART DC (-) (24 OR 48V)

Remove: Unplug wire connectors at positions J1, J2, J3, J4, J5, J9 and J10. Remove four Phillips-head screws located near the corners of PCB1. Lift the board out of the enclosure.

Replace: Reverse the removal procedure.

---

POWER SUPPLY (5371110 FTS 371 FTC SMART AC) (5371125 FTS 371 FTC SMART DC (-) 24/48V)

Remove: PCB1 must be removed first since the power supply is located underneath it. First, follow the removal procedure for PCB1. Then, remove the four Phillips-head screws located near the corners of the Power Supply.

Replace: Reverse the removal procedure. Take care to ensure the power supply is connected to PCB1 at J9 and J10.

---

## FTS 371 FH AC (L-864 LED)

---

### LIGHT ENGINE (1370040)

**Remove:** The light engine “saucer” is designed to be replaced as a single assembly and is identical for the AC and DC flashheads (FTS 371 FH AC, FTS 371 FH DC 24V, FTS 371 FH DC 48V). Unfasten the two latches on the front of the beacon’s base. Lift the light engine assembly to expose the wiring harness. Disconnect the light engine from PCB1 by removing the connector at J1. Disconnect the ground wire that is attached to the light engine. Lower the light engine to the closed position. Pull on the ring attached to the hinge pin and remove the hinge pin. Lift the light engine assembly to remove it from the base.

**Replace:** Reinstall in reverse order.

---

### LED DRIVER PCB (2433200 FTS 371 FH AC) (2433300 FTS 371 FH DC 24V) (2433301 FTS 371 FH DC 48V)

**Remove:** Unfasten the two latches on the front of the beacon’s base. Lift the light engine assembly to expose the driver PCB. Disconnect the wires at PCB connector TB1. Unplug the connector at 12 position connector J1. Remove the screws that attach the PCB to the base. Remove the PCB from the base.

**Replace:** Reinstall in reverse order. Be sure to reconnect cable ground conductor to PCB or flashhead base connection point.

## FIRMWARE UPGRADES

---

### PREPARING THE USB DRIVE

The FTS 371 SMART controller is capable of having its firmware upgraded via a USB drive. Firmware files can be found on Flash Technology’s website ([flashtechnology.com/software](http://flashtechnology.com/software)) and must then be loaded to a USB drive. The firmware file must be stored in the root directory of the USB drive (not in a folder).

**Note:** Google Chrome and Safari no longer support in-browser FTP sites. Please use Internet Explorer, Microsoft Edge or Firefox.

---

### UPGRADING FIRMWARE

1. Power down the FTS 371 SMART system.
2. Place the USB drive into the USB slot on the controller’s PCB1.
3. Power up the system.
4. At first, the RED Fail LED will illuminate followed by the GREEN OK LED and the RED FAIL LED alternating in being on and off. This indicates that the Firmware update is being performed. Removing the USB drive at this time will cause the update to fail and for the controller to revert back to the firmware version from when it was manufactured.
5. The firmware update is complete when the OK LED is on solid GREEN.
6. Remove the USB drive.
7. Confirm that the firmware has been properly updated by rebooting the PCB and observing the firmware version indicated at boot-up by the EXT SYNC LED. For example, one flash, pause, followed by one flash indicates version 1.1.

## DOWNGRADING FIRMWARE

1. The FTS 371 SMART controller will typically only accept firmware updates that are greater than the version currently running. The PCB will accept any version of firmware if it is running its backup firmware version. To place the PCB in this mode, simply fail the firmware upgrade process by removing the USB drive while the firmware upgrade is being performed.
2. Now follow the firmware upgrade process

---

## ADDITIONAL NOTES

Flash Technology advises removing the USB drive once the firmware is updated. However, a failure to do this will not result in the firmware being updated with each power cycle. The controller will recognize that the firmware file on the USB drive matches the file that was last used to upgrade it and will not commence the firmware upgrade process.



## SECTION 4 - OPERATING INSTRUCTIONS

### CONTROLLER

The controller begins programmed operation as soon as power is applied. The controller is shipped preconfigured for your application. It is also field customizable.

### MANUAL OVERRIDE OPTION

The unit's operation can be controlled manually by toggling the manual MODE switch. Push the switch up for night mode and down for day mode. The unit will stay in the selected mode for up to 30 minutes if switch is not returned to the AUTO position. The corresponding mode LED (DAY MODE or NIGHT MODE) will blink during a mode override. When the switch is in the center position the controller's mode will be determined by the connected photodiode's reading of ambient lighting.

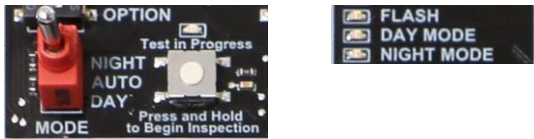

### TOWER CONFIGURATIONS

The configuration switch bank offers the ability to program the controller for a variety of installation situations. The system will come pre-programmed from the factory, but if reprogramming is desired, use the following table to ensure proper operation.

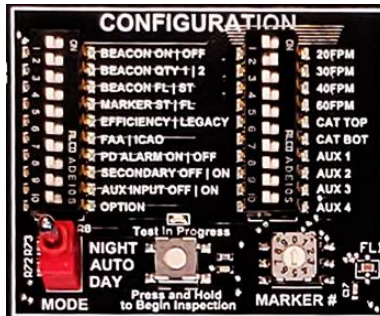

### CONTROLLER CONFIGURATION SWITCH DEFINITIONS

**Table 4.1 – Controller Configuration Switch Definitions**

Switch Label	Switch Position	
	Left	Right
<b>BCN ON   OFF</b> (Beacon alarm on/off)	A BEACON ALARM will be generated if the number of beacon(s) configured (BCN QTY) are not connected and	No BEACON ALARM will be generated.

# FTS 371 SMART USER MANUAL

	working properly. Beacons(s) are powered if wired to J2.	
<b>BCN QTY</b>	Number of beacons is 1	Number of beacons is 2
<b>BCN FL   ST</b>	Beacon(s) are set to flash	Beacon(s) are set to steady burn
<b>MKR ST   FL</b>	Markers are set to steady burn	Markers are set to flashing
<b>EFF   LEG</b>	Shorter flash duration that uses less energy	longer flash duration to resemble an incandescent flash
<b>FAA   ICAO</b>	Domestic air navigation standards	International air navigation standards
<b>PD AL ON   OFF</b>	19 hour mode change alarm "ON" (Photodiode)	19 hour mode change alarm "OFF" (Photodiode)
<b>SECONDARY OFF   ON</b>	No additional FTS 371 controllers are onsite	More than (1) FTS 371 controller is onsite
<b>RADAR OFF   ON</b>	Radar option is "OFF"	Radar option is "ON"
<b>OPTION</b>	Factory reserved (currently unused)	
<b>20FPM</b>	No selection	Sets system for 20 flashes per minute
<b>30FPM</b>	No selection	Sets system for 30 flashes per minute
<b>40FPM</b>	No selection	Sets system for 40 flashes per minute
<b>60 FPM</b>	No selection	Sets system for 60 flashes per minute
<b>CAT T</b>		
<b>CAT B</b>		
<b>AUX 1 - AUX 4</b>	Factory reserved (currently unused)	

## MARKER # CONFIGURATION SWITCH

Switch Label	Switch Position
Marker #	0 = No Markers 1 to 8 = Number of Connected Markers

The CONFIG ERROR LED will be on in cases of the following invalid configurations:

- BCN ST and MKR FL selected
- No FPM selection or more than one FPM selection
- GPS Configuration for both ORGA and UNIMAR synchronization
- RADAR ON and SECONDARY ON
- CAT T and CAT B switches both ON,
- CAT T or CAT B ON and 20FPM or 30FPM selected)

## ALARM INDICATORS

**Table 4.2 – Alarms Indicator Names and Descriptions**

Alarm Indicator Name	Description	Resolution
<b>BEACON ALARM</b>	The controller has detected that the beacon output circuit is not drawing the proper amount of current for the selected configuration. If the controller's configuration matches the actual setup of the system, then	<ol style="list-style-type: none"> <li>1. Confirm that the controller is properly configured</li> <li>2. Replace the failed beacon(s)</li> </ol>

# FTS 371 SMART USER MANUAL

	this alarm indicates that one or more connected FTS 371 FH beacons have failed.	
<b>MARKER ALARM</b>	The controller detects fewer operating markers than its configuration. If the controller's configuration (MARKER #) matches the actual setup of the system, then this alarm indicates that one or more of the connected MKR 371 / MKR 372 IR lights have failed.	<ol style="list-style-type: none"> <li>1. Confirm that the MARKER # configuration dial is set to the actual number of connected markers</li> <li>2. Replace the failed marker lights</li> </ol>
<b>PHOTODIODE</b>	The controller has detected the absence of a mode change in the last 19 hours. This could indicate the failure of the photodiode.	<ol style="list-style-type: none"> <li>1. Visually confirm that the photodiode is properly connected</li> <li>2. Perform the <a href="#">Checkout Procedure</a> (page 19).</li> <li>3. If the alarm persists, replace the photodiode</li> <li>4. If the alarm persists replace PCB1</li> </ol>
<b>CONFIG ERROR</b>	The controller has identified that the current configuration settings are invalid.	<ol style="list-style-type: none"> <li>1. Confirm that the configurations settings are correct and valid.</li> </ol>

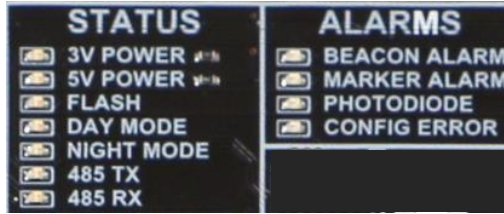

## FLASHHEAD/BEACON LED INDICATORS

Indicator LEDs on the PCB provide status information helpful in troubleshooting.



**Table 4.3 – Beacon LED Indicators Descriptions**

LED	Indication
<b>Power</b>	Steady on to indicate the board’s 5V power supply is on.
<b>AC Sense</b>	On when AC/DC source power is applied to the Beacon. When powered by FTS 371 controller, this LED will flash corresponding to the on/off pulsing power from the controller that communicates flash type and specification.
<b>Flash</b>	On when the LED strings are On.
<b>Fault</b>	On when a fault is detected on either beacon LED string. Turns on and off each flash cycle. When 4 consecutive flash cycle faults are detected, the beacon LED strings turn off until the next day to night transition or after removal of applied power for more than 30 seconds.
<b>ICAO</b>	On when the board is running in ICAO mode. Off in FAA mode.

## FLASHHEAD/BEACON SWITCH BANK

When the FTS 371 FH is not connected to an FTS 371 FTC controller, the switch bank will be used to program the beacon for a variety of installation situations. *However when an FTS 371 controller is connected, the flash head switch bank settings will be ignored.*



## FLASHHEAD/BEACON SWITCH DEFINITIONS

(When an FTS 371 FTC controller is not connected.)

**Table 4.4 – Beacon Switch Position Descriptions**

Flash Head Mode	Switch Position	
	Left	Right
<b>EFF / LEG</b>	EFF - shorter flash duration that uses less energy	LEG - longer flash duration to resemble an incandescent flash
<b>ICAO / FAA</b>	ICAO - international air navigation standards	FAA - domestic air navigation standards
<b>20 FPM / 30 FPM</b>	20FPM - 20 flashes per minute	30FPM - 30 flashes per minute

## FTS 371 SMART USER MANUAL

<b>STEADY</b>	N/A	LEG and 30FPM - When LEG and 30FPM are moved to the right (ON) position, the flash head LEDs will be on steady.
---------------	-----	---

### MAJOR TROUBLESHOOTING SYMPTOMS

**Table 4.5 – Troubleshooting Symptoms and Resolutions**

Symptom	Possible Cause in order of Likelihood
All lights fail	<ol style="list-style-type: none"> <li>2. Main power failure</li> <li>3. External circuit breaker</li> <li>4. Blown fuse on the controller’s PCB1</li> <li>5. PCB1 Failure</li> </ol>
Single light fails	<ol style="list-style-type: none"> <li>1. Wiring to beacon is open or short</li> <li>2. Individual lighting fixture has failed</li> </ol>
Erratic operation	<ol style="list-style-type: none"> <li>1. Loose connections</li> <li>2. PCB1 Failure</li> </ol>
Beacon/marker alarm	<ol style="list-style-type: none"> <li>1. Normal if a light fixture is out</li> <li>2. PCB1 is configured incorrectly for the connected lighting equipment</li> </ol>
False alarm	<ol style="list-style-type: none"> <li>1. Check for correct alarm connections: normally open (NO) contacts close on alarm, normally closed (NC) contacts open on alarm</li> <li>2. PCB1 failure</li> </ol>
Lights do not flash	<ol style="list-style-type: none"> <li>1. Confirm that the BCN and/or MKR flash configuration settings are set to FL (flashing) and not ST (steady)</li> <li>2. PCB1 failure</li> </ol>
Lights operate continuously	<ol style="list-style-type: none"> <li>1. A photodiode is not connected at J5 terminals 7 and 8</li> <li>2. The photodiode has failed</li> <li>3. PCB1 Failure</li> <li>4. A remote data command has put the system into an extended mode override</li> </ol>
Beacon/marker alarm will not reset	<ol style="list-style-type: none"> <li>1. Alarm can only be reset by a mode transition controlled by the photodiode</li> <li>2. Check the photodiode connections</li> </ol>

## SECTION 5 – CUSTOMER SUPPORT

### CONTACT INFORMATION

**Customer Service:** 1-800-821-5825

**Telephone:** (615) 503-2000

**Fax:** (615) 261-2600

**Website:** [flashtechnology.com](http://flashtechnology.com)

**Shipping Address:**

Flash Technology  
332 Nichol Mill Lane  
Franklin, TN 37067

### ORDERING PARTS

To order spare, replacement or optional parts, contact Inside Sales at 1-800-821-5825.

**Table 5.1 – Replacement Parts**

System Component	Item	Description	Part Number
FTS 371 FTC SMART AC	PCB1	PCB FTS 371 FTC SMART AC	2151500T
FTS 371 FTC SMART DC	PCB1	PCB FTS 371 FTC SMART DC	2153500T
FTS 371 FTC SMART DC (-)	PCB1	PCB FTS 371 FTC SMART DC (-)	2153510
FTS 371 FTC SMART AC	Power Supply	PWR SUP FTS 371 SMART AC FTC	5371110
FTS 371 FTC SMART DC (-) 24/48V	Power Supply	POWER SUPPLY FTS 371 SMART (-) 24/48V	5371125
FTS 371 FTC SMART (AC or DC)	PCB1: F1/F2	Fuse, 10A	11000016013
FTS 371 FTC SMART (AC or DC)	GPS Board	PCB FTS 371 GPS OPTION	2433000T
FTS 371 FTC SMART (AC or DC)	GPS Kit	FTS 371 GPS SYNC KIT	1370285
FTS 371 FH (AC or DC)	Light Engine	FH 370/371 IR Light Engine Assy.	1370040
FTS 371 FH AC	PCB1	PCB FTS 371 FH AC IR	2433200T
FTS 371 FH DC 24V	PCB1	PCB FTS 371 FH DC 24V IR	2433300T
FTS 371 FH DC 48V	PCB1	PCB FTS 371 FH DC 48V IR	2433301T
System	Photodiode	PHD 516, SHIELDED	1855516

### RMA POLICY

If any system or part(s) purchased from Flash Technology needs to be returned for any reason (subject to the warranty policy), please see the current RMA policy available online at [flashtechnology.com/rma](http://flashtechnology.com/rma)

## FTS 371 SMART USER MANUAL

To initiate an RMA, call the Flash Technology Technical Support at 1-800-821-5825, option 9. Tech Support is available M-F, 7 a.m. to 7 p.m. CT.

Emailing a completed RMA request form to [FlashSupport@spx.com](mailto:FlashSupport@spx.com) can also start the process on sites not requiring detailed troubleshooting. Complete the online form at [flashtechnology.com/rma-request-form](https://flashtechnology.com/rma-request-form)

**NOTE:** An RMA number must be requested from Flash Technology prior to return of any product. No returned product will be processed without an RMA number. Failure to follow the below procedure may result in additional charges and delays. Any product received without an RMA number is subject to return back to the sender. All RMA numbers are valid for 30 days.